

Appendices

[Go to main text](#)

Etanercept, infliximab and adalimumab for the treatment of psoriatic arthritis: a systematic review and economic evaluation

M Rodgers, D Epstein, L Bojke, H Yang, D Craig, T Fonseca, L Myers, I Bruce, R Chalmers, S Bujkiewicz, M Lai, N Cooper, K Abrams, D Spiegelhalter, A Sutton, M Sculpher and N Woolacott



February 2011
10.3310/hta15100

Health Technology Assessment
NIHR HTA programme
www.hta.ac.uk





How to obtain copies of this and other HTA programme reports

An electronic version of this title, in Adobe Acrobat format, is available for downloading free of charge for personal use from the HTA website (www.hta.ac.uk). A fully searchable DVD is also available (see below).

Printed copies of HTA journal series issues cost £20 each (post and packing free in the UK) to both public **and** private sector purchasers from our despatch agents.

Non-UK purchasers will have to pay a small fee for post and packing. For European countries the cost is £2 per issue and for the rest of the world £3 per issue.

How to order:

- fax (with **credit card details**)
- post (with **credit card details** or **cheque**)
- phone during office hours (**credit card** only).

Additionally the HTA website allows you to either print out your order or download a blank order form.

Contact details are as follows:

Synergie UK (HTA Department)
Digital House, The Loddon Centre
Wade Road
Basingstoke
Hants RG24 8QW

Email: orders@hta.ac.uk

Tel: 0845 812 4000 – ask for ‘HTA Payment Services’
(out-of-hours answer-phone service)

Fax: 0845 812 4001 – put ‘HTA Order’ on the fax header

Payment methods

Paying by cheque

If you pay by cheque, the cheque must be in **pounds sterling**, made payable to *University of Southampton* and drawn on a bank with a UK address.

Paying by credit card

You can order using your credit card by phone, fax or post.

Subscriptions

NHS libraries can subscribe free of charge. Public libraries can subscribe at a reduced cost of £100 for each volume (normally comprising 40–50 titles). The commercial subscription rate is £400 per volume (addresses within the UK) and £600 per volume (addresses outside the UK). Please see our website for details. Subscriptions can be purchased only for the current or forthcoming volume.

How do I get a copy of HTA on DVD?

Please use the form on the HTA website (www.hta.ac.uk/htacd/index.shtml). *HTA on DVD* is currently free of charge worldwide.

The website also provides information about the HTA programme and lists the membership of the various committees.

Appendix 1

Literature search strategies

Full details of all databases searched and search strategies are provided below. Numbers in brackets reflect the number of hits retrieved.

The search strategy was designed for searching MEDLINE through the OvidSP interface and was adapted as appropriate for all other databases searched, taking into account differences in indexing terms and search syntax for each database.

Clinical effectiveness: search for RCTS

MEDLINE: OvidSP

- <http://ovidsp.ovid.com/>

The MEDLINE search covered the date range 1950 to week 5 May 2009 for adalimumab and 1 April 2004 to week 5 May 2009, using the search field 'ed: Entry Date', for etanercept and infliximab. The search was carried out on 9 June 2009 and identified 399 records.

The strategy uses the Cochrane Highly Sensitive Search Strategy for identifying randomised trials in MEDLINE, sensitivity-maximising version (lines 1–11).²⁰²

1. randomized controlled trial.pt. (272,711)
2. controlled clinical trial.pt. (79,394)
3. randomized.ab. (182,345)
4. placebo.ab. (112,659)
5. drug therapy.fs. (1,317,603)
6. randomly.ab. (132,262)
7. trial.ab. (189,408)
8. groups.ab. (909,284)
9. or/1-8 (2,406,033)
10. (animals not (humans and animals)).sh. (3,290,537)
11. 9 not 10 (2,040,011)
12. Arthritis, Psoriatic/ (2223)
13. (psoria\$adj2 (arthrit\$or arthropath\$)).ti,ab. (3596)
14. 12 or 13 (4138)
15. (etanercept or enbrel).ti,ab,rn. (2085)
16. (infliximab or remicade).ti,ab,rn. (4715)
17. 15 or 16 (5890)
18. 11 and 14 and 17 (450)
19. (200404\$or 200405\$or 200406\$or 200407\$or 200408\$or 200409\$ or 200410\$or 200411\$or 200412\$or 2005\$or 2006\$or 2007\$or 2008\$ or 2009\$).ed. (3,555,234)
20. 18 and 19 (356)
21. (adalimumab or humira or D2E7 or (D2 adj E7)).ti,ab,rn. (1161)
22. 11 and 14 and 21 (143)
23. 20 or 22 (399)

MEDLINE In-Process & Other Non-Indexed Citations: OvidSP

- <http://ovidsp.ovid.com/>

The MEDLINE In-Process & Other Non-Indexed Citations search, database dated 8 June 2009, was carried out on 9 June 2009 and identified five records.

The strategy uses the Cochrane Highly Sensitive Search Strategy for identifying randomised trials in MEDLINE, sensitivity-maximising version (lines 1–11).

1. randomized controlled trial.pt. (387)
2. controlled clinical trial.pt. (40)
3. randomized.ab. (7406)
4. placebo.ab. (3160)
5. drug therapy.fs. (20)
6. randomly.ab. (8231)
7. trial.ab. (7527)
8. groups.ab. (42,954)
9. or/1-8 (56,348)
10. (animals not (humans and animals)).sh. (8)
11. 9 not 10 (56,346)
12. Arthritis, Psoriatic/ (1)
13. (psoria\$adj2 (arthrit\$or arthropath\$)).ti,ab. (125)
14. 12 or 13 (125)
15. (etanercept or enbrel).ti,ab,rn. (164)
16. (infliximab or remicade).ti,ab,rn. (287)
17. (adalimumab or humira or D2E7 or (D2 adj E7)).ti,ab,rn. (110)
18. or/15-17 (438)
19. 11 and 14 and 18 (5)

EMBASE: OvidSP

- <http://ovidsp.ovid.com/>

The EMBASE search covered the date range 1980–2009 week 23 for adalimumab and 1 January 2004 to week 23 2009, using the search field 'em: Entry Week', for etanercept and infliximab. The search was carried out on 9 June 2009 and identified 369 records.

The strategy uses the Hedges Team best-sensitivity strategy for detecting clinically sound treatment studies in EMBASE (lines 17–20).²⁰³

Note: A pragmatic approach was taken to reduce the number of irrelevant records retrieved and to negate the over indexing of records in EMBASE; Emtree drug terms were focused in this strategy.

1. Psoriatic Arthritis/ (4225)
2. (psoria\$adj2 (arthrit\$or arthropath\$)).ti,ab. (3339)
3. 1 or 2 (5024)
4. *Etanercept/ (1973)
5. (etanercept or enbrel).ti,ab. (2192)
6. *Infliximab/ (3482)
7. (infliximab or remicade).ti,ab. (3991)
8. or/4-7 (6134)
9. (2004\$or 2005\$or 2006\$or 2007\$or 2008\$or 2009\$.em. (3,193,493)

10. 8 and 9 (4694)
11. *Adalimumab/ (881)
12. (adalimumab or humira or D2E7 or (D2 adj E7)).ti,ab. (958)
13. 11 or 12 (1236)
14. 3 and 10 (500)
15. 3 and 13 (219)
16. 14 or 15 (561)
17. random\$.tw. (399,406)
18. clinical trial\$.mp. (608,378)
19. exp Health Care Quality/ (802,714)
20. or/17-19 (1,446,048)
21. 16 and 20 (369)

CENTRAL: The Cochrane Library

- www3.interscience.wiley.com/cgi-bin/mrwhome/106568753/HOME

Issue 2, 2009, of The Cochrane Library was searched to identify trials on CENTRAL. The etanercept and infliximab search covered the date range 2004–2009. The search for adalimumab had no date limits. The search was carried out on 9 June 2009 and identified 37 records.

- #1 MeSH descriptor Arthritis, Psoriatic, this term only (99)
- #2 (psoria* NEAR/2 arthrit*) in Clinical Trials (132)
- #3 (psoria* NEAR/2 arthropath*) in Clinical Trials (6)
- #4 (#1 OR #2 OR #3) (199)
- #5 (etanercept or enbrel):ti,ab,kw, from 2004 to 2009 in Clinical Trials (184)
- #6 (infliximab or remicade):ti,ab,kw, from 2004 to 2009 in Clinical Trials (224)
- #7 (adalimumab or humira or D2E7 or (D2 adj E7)):ti,ab,kw in Clinical Trials (91)
- #8 (#5 OR #6 OR #7) (579)
- #9 (#4 AND #8) (37)

SCI: ISI Web of Knowledge

- <http://wok.mimas.ac.uk>

The SCI search covered the date range 1990–2009 for adalimumab and 2004–9 for etanercept and infliximab. The search was carried out on 9 June 2009 and identified 302 records.

The strategy uses the terms used in the 2006 HTA report⁷³ to identify RCTs in the SCI (lines #1–7).

- # 13 302 #10 or #12
Databases=SCI-EXPANDED Timespan=All Years
- # 12 108 #7 and #8 and #11
Databases=SCI-EXPANDED Timespan=All Years
- # 11 1,676 TS=(adalimumab or humira or D2E7 or "D2 E7")
Databases=SCI-EXPANDED Timespan=All Years
- # 10 275 #7 and #8 and #9
Databases=SCI-EXPANDED Timespan=2004–2009
- # 9 9,327 TS=(etanercept or enbrel or infliximab or remicade)
Databases=SCI-EXPANDED Timespan=All Years
- # 8 4,706 TS=((psoria* same arthrit*) or (psoria* same arthropath*))
Databases=SCI-EXPANDED Timespan=All Years
- # 7 >100,000 #5 not #6

Databases=SCI-EXPANDED Timespan= All Years
 # 6 >100,000 TS=(animal or animals or dog or dogs or hamster* or mice or mouse or rat or rats
 or bovine or sheep or guinea*)
 Databases=SCI-EXPANDED Timespan=All Years
 # 5 >100,000 #1 or #2 or #3 or #4
 Databases=SCI-EXPANDED Timespan=All Years
 # 4 >100,000 TS=(placebo* or random* or control* or prospectiv* or volunteer*)
 Databases=SCI-EXPANDED Timespan=All Years
 # 3 >100,000 TS=(clinic* same trial*)
 Databases=SCI-EXPANDED Timespan=All Years
 # 2 >100,000 TS=((singl* or doubl* or trebl* or tripl*) SAME (blind* or mask*))
 Databases=SCI-EXPANDED Timespan=All Years
 # 1 >100,000 TS=((study or studies) SAME design*)
 Databases=SCI-EXPANDED Timespan=All Years

CPCI-S: ISI Web of Knowledge

- <http://wok.mimas.ac.uk>

The CPCI-S search covered the date range 1990–2009 for adalimumab and 2004–9 for etanercept and infliximab. The search was carried out on 9 June 2009 and identified 37 records.

The strategy uses the terms used in the 2006 HTA report⁷³ to identify RCTs in the CPCI-S (previously ISI Science and Technology Proceedings) (lines #1–7).

13 37 #10 or #12
 Databases=CPCI-S Timespan=1990–2009
 # 12 12 #7 and #8 and #11
 Databases=CPCI-S Timespan=1990–2009
 # 11 635 TS=(adalimumab or humira or D2E7 or “D2 E7”)
 Databases=CPCI-S Timespan=1990–2009
 # 10 29 #7 and #8 and #9
 Databases=CPCI-S Timespan=2004–2009
 # 9 2,588 TS=(etanercept or enbrel or infliximab or remicade)
 Databases=CPCI-S Timespan=1990–2009
 # 8 797 TS=((psoria* same arthrit*) or (psoria* same arthropath*))
 Databases=CPCI-S Timespan=1990–2009
 # 7 >100,000 #5 not #6
 Databases=CPCI-S Timespan=1990–2009
 # 6 >100,000 TS=(animal or animals or dog or dogs or hamster* or mice or mouse or rat or rats
 or bovine or sheep or guinea*)
 Databases=CPCI-S Timespan=1990–2009
 # 5 >100,000 #1 or #2 or #3 or #4
 Databases=CPCI-S Timespan=1990–2009
 # 4 >100,000 TS=(placebo* or random* or control* or prospectiv* or volunteer*)
 Databases=CPCI-S Timespan=1990–2009
 # 3 22,210 TS=(clinic* same trial*)
 Databases=CPCI-S Timespan=1990–2009
 # 2 15,096 TS=((singl* or doubl* or trebl* or tripl*) SAME (blind* or mask*))
 Databases=CPCI-S Timespan=1990–2009
 # 1 >100,000 TS=((study or studies) SAME design*)

Databases=CPCI-S Timespan=1990–2009

ClinicalTrials.gov

- <http://clinicaltrials.gov/>

The ClinicalTrials.gov registry was searched for ongoing trials information. The search was carried out on 9 June 2009 and identified 27 studies.

Basic Search: ((psoriatic arthritis OR psoriatic arthropathy) AND (etanercept OR enbrel OR infliximab OR remicade OR adalimumab or humira or D2E7 or 'D2 E7'))

mRCT

- <http://controlled-trials.com/mrct>

The *mRCT* was searched for ongoing trials information. The search was carried out on 10 June 2009 and identified 41 studies.

SEARCH FOR [all registers]: ((“psoriatic arthritis” OR “psoriatic arthropathy”) AND (etanercept OR enbrel OR infliximab OR remicade OR adalimumab or humira or D2E7 or “D2 E7”))

Cost-effectiveness search

MEDLINE: OvidSP

- <http://ovidsp.ovid.com/>

The MEDLINE search covered the date range 1950 to week 1 June 2009 for adalimumab and 1 April 2004 to week 1 June 2009, using the search field ‘ed: Entry Date’, for etanercept and infliximab. The search was carried out on 11 June 2009 and identified 24 records.

The strategy uses the CRD NHS EED strategy for identifying economic evaluations in MEDLINE (lines 13–39).²⁰⁴

1. Arthritis, Psoriatic/ (2225)
2. (psoria\$adj2 (arthrit\$or arthropath\$)).ti,ab. (3601)
3. 1 or 2 (4143)
4. (etanercept or enbrel).ti,ab,rn. (2086)
5. (infliximab or remicade).ti,ab,rn. (4731)
6. 4 or 5 (5906)
7. 3 and 6 (488)
8. (200404\$or 200405\$or 200406\$or 200407\$or 200408\$or 200409\$ or 200410\$or 200411\$or 200412\$or 2005\$or 2006\$or 2007\$ or 2008\$or 2009\$).ed. (3,568,700)
9. 7 and 8 (387)
10. (adalimumab or humira or D2E7 or (D2 adj E7)).ti,ab,rn. (1164)
11. 3 and 10 (152)
12. 9 or 11 (432)
13. economics/ (25,433)
14. exp “Costs and Cost Analysis”/ (143,147)
15. VALUE OF LIFE/ (5039)
16. economics, dental/ (1776)
17. exp economics, hospital/ (15,981)
18. economics, medical/ (7044)

19. economics, nursing/ (3784)
20. economics, pharmaceutical/ (2048)
21. (econom\$or cost or costs or costly or costing or price or prices or pricing or pharmacoconom\$).ti,ab. (300,152)
22. (expenditure\$not energy).ti,ab. (12,542)
23. (value adj1 money).ti,ab. (12)
24. budget\$.ti,ab. (12,911)
25. or/13-24 (407,009)
26. ((energy or oxygen) adj cost).ti,ab. (2082)
27. (metabolic adj cost).ti,ab. (512)
28. ((energy or oxygen) adj expenditure).ti,ab. (11,540)
29. or/26-28 (13,584)
30. 25 not 29 (403,828)
31. letter.pt. (654,164)
32. editorial.pt. (239,274)
33. historical article.pt. (272,822)
34. or/31-33 (1,155,003)
35. 30 not 34 (381,317)
36. Animals/ (4,399,394)
37. Humans/ (10,777,302)
38. 36 not (36 and 37) (3,292,558)
39. 35 not 38 (361,076)
40. 12 and 39 (24)

MEDLINE In-Process & Other Non-Indexed Citations: OvidSP

- <http://ovidsp.ovid.com/>

The MEDLINE In-Process & Other Non-Indexed Citations search, database dated 11 June 2009, was carried out on 12 June 2009 and identified one record.

The strategy uses the CRD NHS EED strategy for identifying economic evaluations in MEDLINE (lines 9–35).

1. Arthritis, Psoriatic/ (1)
2. (psoria\$adj2 (arthrit\$or arthropath\$)).ti,ab. (130)
3. 1 or 2 (130)
4. (etanercept or enbrel).ti,ab,rn. (174)
5. (infliximab or remicade).ti,ab,rn. (298)
6. (adalimumab or humira or D2E7 or (D2 adj E7)).ti,ab,rn. (113)
7. or/4-6 (457)
8. 3 and 7 (21)
9. economics/ (1)
10. exp "Costs and Cost Analysis"/ (7)
11. VALUE OF LIFE/ (0)
12. economics, dental/ (0)
13. exp economics, hospital/ (11)
14. economics, medical/ (0)
15. economics, nursing/ (0)
16. economics, pharmaceutical/ (0)
17. (econom\$or cost or costs or costly or costing or price or prices or pricing or pharmacoconom\$).ti,ab. (15,266)
18. (expenditure\$not energy).ti,ab. (422)

19. (value adj1 money).ti,ab. (2)
20. budget\$.ti,ab. (620)
21. or/9-20 (15,898)
22. ((energy or oxygen) adj cost).ti,ab. (103)
23. (metabolic adj cost).ti,ab. (14)
24. ((energy or oxygen) adj expenditure).ti,ab. (435)
25. or/22-24 (536)
26. 21 not 25 (15,762)
27. letter.pt. (14,507)
28. editorial.pt. (8936)
29. historical article.pt. (2)
30. or/27-29 (23,445)
31. 26 not 30 (15,515)
32. Animals/ (12)
33. Humans/ (105)
34. 32 not (32 and 33) (8)
35. 31 not 34 (15,515)
36. 8 and 35 (1)

EMBASE: OvidSP

- <http://ovidsp.ovid.com/>

The EMBASE search covered the date range 1980–2009 week 23 for adalimumab and 1 January 2004–9 week 23, using the search field “em: Entry Week”, for etanercept and infliximab. The search was carried out on 12 June 2009 and identified 80 records.

The strategy uses the CRD NHS EED strategy for identifying economic evaluations in EMBASE (lines 17–43).

Note: A pragmatic approach was taken to reduce the number of irrelevant records retrieved and to negate the over indexing of records in EMBASE; Emtree drug terms were focused in this strategy.

1. Psoriatic Arthritis/ (4225)
2. (psoria\$adj2 (arthrit\$or arthropath\$)).ti,ab. (3339)
3. 1 or 2 (5024)
4. *Etanercept/ (1973)
5. (etanercept or enbrel).ti,ab. (2192)
6. *Infliximab/ (3482)
7. (infliximab or remicade).ti,ab. (3991)
8. or/4-7 (6134)
9. (2004\$or 2005\$or 2006\$or 2007\$or 2008\$or 2009\$).em. (3,193,493)
10. 8 and 9 (4694)
11. *Adalimumab/ (881)
12. (adalimumab or humira or D2E7 or (D2 adj E7)).ti,ab. (958)
13. 11 or 12 (1236)
14. 3 and 10 (500)
15. 3 and 13 (219)
16. 14 or 15 (561)
17. Health Economics/ (10,611)
18. exp Economic Evaluation/ (104,472)
19. exp “Health Care Cost”/ (107,017)

20. exp PHARMACOECONOMICS/ (56,975)
21. (econom\$or cost or costs or costly or costing or price or prices or pricing or pharmaco-economic\$).tw. (234,263)
22. (expenditure\$not energy).ti,ab. (9859)
23. (value adj2 money).ti,ab. (462)
24. budget\$.ti,ab. (8863)
25. or/17-24 (347,643)
26. (metabolic adj cost).ti,ab. (388)
27. ((energy or oxygen) adj cost).ti,ab. (1707)
28. ((energy or oxygen) adj expenditure).ti,ab. (10,088)
29. or/26-28 (11,689)
30. 25 not 29 (345,077)
31. (letter or note or editorial).pt. (925,192)
32. 30 not 31 (298,277)
33. exp Animal/ (18,276)
34. exp Animal Experiment/ (1,298,147)
35. Nonhuman/ (3,232,877)
36. (rat or rats or mouse or mice or hamster or hamsters or animal or animals or dog or dogs or cat or cats or bovine or sheep).ti,ab. (1,737,766)
37. or/33-36 (3,643,672)
38. exp human/ (6,568,828)
39. exp Human Experiment/ (257,542)
40. 38 or 39 (6,569,696)
41. 37 not (37 and 40) (2,983,952)
42. 32 not 41 (274,297)
43. 16 and 42 (80)

CENTRAL: The Cochrane Library

- www3.interscience.wiley.com/cgi-bin/mrwhome/106568753/HOME

A search of CENTRAL was not repeated for cost-effectiveness evidence. The search carried out on 9 June 2009 (shown in *Cinical effectiveness: search for RCTs*) was not limited by study design and would also have identified economic evaluations.

SCI: ISI Web of Knowledge

- <http://wok.mimas.ac.uk>

The SCI search covered the date range 1900–2009 for adalimumab and 2004–9 for etanercept and infliximab. The search was carried out on 12 June 2009 and identified 31 records.

The strategy uses the terms used in the 2006 HTA report⁷³ to identify economic evaluations in the SCI (lines #7–10).

10 31 #8 not #9

Databases=SCI-EXPANDED Timespan=1900–2009

9 >100,000 TS=(animal or animals or dog or dogs or hamster* or mice or mouse or rat or rats or bovine or sheep or guinea*)

Databases=SCI-EXPANDED Timespan=1900–2009

8 33 #6 and #7

Databases=SCI-EXPANDED Timespan=1900–2009

7 >100,000 TS=(econom* or cost or costs or costly or costing or price or prices or pricing or pharmaco-econom* or budget*)

Databases=SCI-EXPANDED Timespan=1900–2009
 # 6 666 #3 or #5
 Databases=SCI-EXPANDED Timespan=1900–2009
 # 5 211 #1 and #4
 Databases=SCI-EXPANDED Timespan=1900–2009
 # 4 1,699 TS=(adalimumab or humira or D2E7 or “D2 E7”)
 Databases=SCI-EXPANDED Timespan=1900–2009
 # 3 570 #1 and #2
 Databases=SCI-EXPANDED Timespan=1900–2009
 # 2 7,383 TS=(etanercept or enbrel or infliximab or remicade)
 Databases=SCI-EXPANDED Timespan=2004–2009
 # 1 4,736 TS=((psoria* same arthrit*) or (psoria* same arthropath*))
 Databases=SCI-EXPANDED Timespan=1900–2009

CPCI-S: ISI Web of Knowledge

- <http://wok.mimas.ac.uk>

The CPCI-S search covered the date range 1990–2009 for adalimumab and 2004–9 for etanercept and infliximab. The search was carried out on 12 June 2009 and identified three records.

The strategy uses the terms used in the 2006 HTA report to identify economic evaluations in the CPCI-S (previously ISI Science and Technology Proceedings) (lines #7–10).

10 3 #8 not #9
 Databases=CPCI-S Timespan=1990–2009
 # 9 >100,000 TS=(animal or animals or dog or dogs or hamster* or mice or mouse or rat or rats or bovine or sheep or guinea*)
 Databases=CPCI-S Timespan=1990–2009
 # 8 3 #6 and #7
 Databases=CPCI-S Timespan=1990–2009
 # 7 >100,000 TS=(econom* or cost or costs or costly or costing or price or prices or pricing or pharmacoconom* or budget*)
 Databases=CPCI-S Timespan=1990–2009
 # 6 196 #3 or #5
 Databases=CPCI-S Timespan=1990–2009
 # 5 62 #1 and #4
 Databases=CPCI-S Timespan=1990–2009
 # 4 651 TS=(adalimumab or humira or D2E7 or “D2 E7”)
 Databases=CPCI-S Timespan=1990–2009
 # 3 140 #1 and #2
 Databases=CPCI-S Timespan=1990–2009
 # 2 2,192 TS=(etanercept or enbrel or infliximab or remicade)
 Databases=CPCI-S Timespan=2004–2009
 # 1 814 TS=((psoria* same arthrit*) or (psoria* same arthropath*))
 Databases=CPCI-S Timespan=1990–2009

NHS EED

- www.crd.york.ac.uk/CRDWeb/

The NHS EED was searched for economic evaluations. As no records were identified in the 2006 HTA review, no date limits were set. The search was carried out on 12 June 2009 and identified seven records.

Note: The strategy was run across the entire CRD databases and the final results shown here, 20 records, relate to the total number of records found.

1. # 1 MeSH Arthritis, Psoriatic (22)
2. # 2 (psoria* NEAR arthrit*) (43)
3. # 3 (psoria* NEAR arthropath*) (1)
4. # 4 #1 or #2 or #3 (44)
5. # 5 etanercept OR enbrel OR infliximab OR remicade (165)
6. # 6 adalimumab OR humira OR D2E7 OR "D2 AND E7" (48)
7. # 7 #5 or #6 (182)
8. # 8 #4 and #7 (20)

HEED

- <http://heed.wiley.com/ohe/>

The HEED was searched for economic evaluations. As no records were identified in the 2006 HTA review, no date limits were set. The search was carried out on 12 June 2009 and identified eight records.

Compound Search

All Data: ((psoria* AND arthrit*) OR (psoria* AND arthropath*))

AND

All Data: etanercept OR enbrel OR infliximab OR remicade OR adalimumab OR humira OR D2E7 OR 'D2 E7'

EconLit: OvidSP

- <http://ovidsp.ovid.com/>

The American Economic Association's electronic bibliography, EconLit, database was searched for economic evaluations. The search carried out on 12 June 2009, covering the date range 1969–May 2009, identified no records.

1. (psoria\$adj2 (arthrit\$or arthropath\$)).ti,ab. (0)
2. (etanercept or enbrel or infliximab or remicade or adalimumab or humira or D2E7 or "D2 E7").ti,ab. (3)
3. #1 and #2 (0)

Additional searches

Side-effects/adverse effects search

The following resources were searched for information on side-effects:

- Center for Drug Evaluation and Research. *Drugs@FDA*. Silver Spring, MD: US Food and Drug Administration [cited 2009 Jun 08]. URL: www.accessdata.fda.gov/scripts/cder/drugsatfda/index.cfm
- *EPARs for authorised medicinal products for human use*. London: European Medicines Agency [cited 8 June 2009]. URL: www.emea.europa.eu/htms/human/epar/a.htm

Additional information on side-effects was gathered by supplementary searches. The following searches were designed to capture the major side-effects that had been identified as arising from the use of etanercept, infliximab or adalimumab: urinary tract infections, lower respiratory tract

infections, skin infections, bone infections, joint infections, malignancy, and the reactivation of latent TB.

A pragmatic approach to searching was adopted for the supplementary side-effects search. This can be seen in the reliance of indexed terms to search for the side-effects and the use of subheadings linked to specific side-effects, such as the MeSH subheading 'Chemically Induced' and the Emtree subheading 'Side Effect'. This search approach enhances the precision of a search but has an unknown effect on its sensitivity.

MEDLINE: OvidSP

- <http://ovidsp.ovid.com/>

The MEDLINE search covered the date range 1950 to week 1 June 2009. The search was carried out on 16 June 2009 and identified 60 records.

1. (etanercept or enbrel).ti,ab. (2086)
2. (infliximab or remicade).ti,ab. (3743)
3. (adalimumab or humira or D2E7 or (D2 adj E7)).ti,ab. (878)
4. or/1-3 (5297)
5. Safety/ (26,929)
6. (safe or safety).ti,ab. (271,847)
7. (side effect or side effects).ti,ab. (130,142)
8. treatment emergent.ti,ab. (867)
9. undesirable effect\$.ti,ab. (1448)
10. tolerability.ti,ab. (19,551)
11. Drug Toxicity/ (2820)
12. toxicity.ti,ab. (173,622)
13. Adverse Drug Reaction Reporting Systems/ (3900)
14. adrs.ti,ab. (975)
15. (adverse adj3 (effect or effects or reaction or reactions or event or events or outcome or outcomes)).ti,ab. (147,732)
16. (undesir\$adj2 (effect or effects or reaction or reactions or event or events or outcome or outcomes)).ti,ab. (4632)
17. Drug Hypersensitivity/ (17,725)
18. (hypersensit\$or hyper sensit\$).ti,ab. (45,094)
19. harm\$.ti,ab. (54,739)
20. or/5-19 (750,762)
21. 4 and 20 (1654)
22. exp Infection/ci [Chemically Induced] (2859)
23. exp Urinary Tract Infections/ci [Chemically Induced] (61)
24. exp Respiratory Tract Infections/ci [Chemically Induced] (3678)
25. exp Skin Diseases, Infectious/ci [Chemically Induced] (451)
26. exp Bone Diseases, Infectious/ (27,676)
27. exp Arthritis, Infectious/ci [Chemically Induced] (55)
28. exp Neoplasms/ci [Chemically Induced] (50,219)
29. exp Tuberculosis/ci [Chemically Induced] (315)
30. or/22-29 (84,100)
31. 21 and 30 (60)
32. (animals not (humans and animals)).sh. (3,292,558)
33. 31 not 32 (60)

EMBASE: OvidSP

- <http://ovidsp.ovid.com/>

The EMBASE search covered the date range 1980–2009 week 24. The search was carried out on 17 June 2009 and identified 648 records.

Note: A pragmatic approach was taken to reduce the number of irrelevant records retrieved and to negate the over indexing of records in EMBASE; EMTREE drug terms were focused in this strategy.

1. (etanercept or enbrel).ti,ab. (2202)
2. (infliximab or remicade).ti,ab. (3999)
3. (adalimumab or humira or D2E7 or (D2 adj E7)).ti,ab. (960)
4. or/1-3 (5648)
5. *Etanercept/ (1979)
6. *Infliximab/ (3486)
7. *Adalimumab/ (882)
8. or/5-7 (5086)
9. 4 or 8 (6595)
10. (safe or safety).ti,ab. (246,785)
11. side effect\$.ti,ab. (123,415)
12. treatment emergent.ti,ab. (963)
13. undesirable effect\$.ti,ab. (1421)
14. tolerability.ti,ab. (22,410)
15. toxicity.ti,ab. (164,169)
16. adrs.ti,ab. (1214)
17. (adverse adj3 (effect or effects or reaction or reactions or event or events or outcome or outcomes)).ti,ab. (144,000)
18. Safety/or Drug Safety/ (183,510)
19. Side Effect/ (94,185)
20. Adverse Drug Reaction/ (95,592)
21. Drug Tolerability/ (54,359)
22. Toxicity/or Drug Toxicity/ (47,998)
23. Drug Surveillance Program/ (7235)
24. Adverse Outcome/ (1414)
25. hypersensit\$.ti,ab. (35,011)
26. harm\$.ti,ab. (46,014)
27. Drug Hypersensitivity/ (25,074)
28. or/10-27 (892,235)
29. 9 and 28 (2822)
30. *Etanercept/ae, to [Adverse Drug Reaction, Drug Toxicity] (917)
31. *Infliximab/ae, to [Adverse Drug Reaction, Drug Toxicity] (1636)
32. *Adalimumab/ae, to [Adverse Drug Reaction, Drug Toxicity] (442)
33. or/30-32 (2470)
34. 29 or 33 (3651)
35. Urinary Tract Infection/si [Side Effect] (2059)
36. Lower Respiratory Tract Infection/si [Side Effect] (144)
37. Skin Infection/si [Side Effect] (488)
38. Bone Infection/si [Side Effect] (26)
39. Infectious Arthritis/si [Side Effect] (55)
40. Neoplasm/si [Side Effect] (452)
41. Tuberculosis/si [Side Effect] (1297)
42. or/35-41 (4150)
43. 34 and 42 (648)

Appendix 2

Quality assessment tool

All of the criteria listed below should be scored with one of the following responses:

- yes (Y)
- no (N)
- partial (P)
- not stated (NS)
- not applicable (NA)
- unclear (U).

Study

-
- 1 Were the eligibility criteria for the study adequately specified?
Adequate study population clearly defined
 - 2 Was an a priori power calculation for adequate sample size performed?
 - 3 Was the sample size adequate for the analysis of the primary outcome variable?
 - 4 Was the number of participants who were randomised stated?
 - 5 Was the method used to assign participants to treatment groups truly random?
Adequate computer-generated random numbers, random number tables
Inadequate alternation, case record numbers, birth dates, days of the week
 - 6 Was the trial described as double blind?
 - 7 Was allocation of treatment concealed?
Adequate centralised or pharmacy controlled assignment, serially numbered containers, serially numbered opaque envelopes, on-site computer-based systems where assignment is unreadable until after allocation, other robust measures to prevent revelation of a participant's treatment
Inadequate alternation, case record numbers, days of the week, open random number lists
 - 8 Were the individuals administering the treatment blinded to the treatment allocation?
 - 9 Were the outcome assessors blinded to the treatment allocation?
 - 10 Were the participants blinded to the treatment allocation?
 - 11 Was the blinding procedure successful?
 - 12 Were adequate details of the treatment groups at baseline presented?
Adequate information on age, nature and severity of psoriasis, previous treatments
 - 13 Were the treatment groups comparable at baseline?
Answer 'yes' if no important differences or if appropriate adjustments had been made for any differences in the baseline characteristics of the treatment groups
 - 14 Were the treatment groups similar in terms of co-interventions that could influence the results?
 - 15 Was participant compliance with the assigned treatment adequate?
 - 16 Were all participants who were randomised accounted for at the end of the trial?
 - 17 Was a valid ITT analysis performed?
Adequate all participants randomised included in efficacy analysis, all randomised participants who took at least one dose of trial medication included in efficacy analysis
 - 18 Were at least 80% of those randomised included in the follow-up assessment?
Answer 'yes' if at least 80% of those randomised provided complete data with regard to the primary outcome(s)
-

Quality rating:

- *Excellent* The answer is 'Yes' to all of the criteria.
- *Good* The answer is 'Yes' to all of the following criteria: 1, 3, 4, 6, 10, 12–14, 16–18.
- *Satisfactory* The answer is 'Yes' to all of the following criteria: 1, 3, 6, 13, 17.
- *Poor* The answer is *not* 'Yes' to one or more of the criteria listed for 'Satisfactory'.

Appendix 3

Data extraction tables

Efficacy data extraction: etanercept

Study details and design	Participant details	Intervention/outcome/analyses details	Results
<p>Mease, 2000, USA⁷⁸</p> <p><i>Type of publication:</i> Full publication</p> <p><i>Funding:</i> Immunex Corporation</p> <p><i>Study design:</i> Stage 1: Double-blind RCT, parallel group monotherapy; Stage 2: Open-label follow-up</p> <p><i>Setting:</i> Outpatient</p> <p><i>Duration of follow-up:</i> Stage 1: 12 weeks, stage 2: 24 weeks</p> <p><i>Frequency of follow-up:</i> Stage 1: Baseline, 4, 8 and 12 weeks; Stage 2: 16 and 36 weeks</p> <p><i>Extracted by:</i> HY</p> <p><i>Checked by:</i> MR</p>	<p><i>Inclusion/exclusion criteria:</i> Adults between 18 and 70 years of age with active PsA (defined as three or more swollen joints and three or more tender or painful joints) and an inadequate response to NSAIDs, and were thought candidates for immunomodulatory therapy. Patients taking a stable dose of MTX (≤ 25 mg/week) were permitted to continue with that dose. Other DMARDs were discontinued at least 2 weeks prior to the trial. Corticosteroids were allowed during the study at a dose of ≤ 10 mg/day of prednisone if it was stable for at least 2 weeks prior to the trial and maintained during the trial. For patients with skin involvement psoriasis, therapies had to be discontinued (phototherapy 4 weeks before and topical therapies and oral retinoids 2 weeks before)</p> <p><i>No. randomised:</i> 60</p> <p><i>Age (median age, range)</i> Etanercept: 46.0 years (30.0–70.0 years) Placebo: 43.5 years (24.0–63.0)</p> <p><i>Gender</i> Etanercept, male 16/30 (53%) Placebo, male 18/30 (60%)</p>	<p><i>Intervention: etanercept</i></p> <p>Dose regimen: 25 mg etanercept twice per week</p> <p>Length of treatment: 12 weeks</p> <p>No. randomised: 30 No. completed: 30</p> <p><i>Comparator: placebo</i></p> <p>Dose regimen: placebo twice per week</p> <p>Length of treatment: 12 weeks</p> <p>No. randomised: 30 No. completed: 26</p> <p><i>Primary outcome</i> The proportion of patients meeting the PsARC at 12 weeks</p> <p><i>Sample size calculation</i> Assuming that a response rate of 30% on placebo and 75% on etanercept, the sample size of 30 patients per group gives 80% power to detect a significant difference between treatments in the primary outcome, with $\alpha = 0.05$ (two-sided)</p>	<p>EFFICACY OUTCOMES (STAGE 1, RANDOMISED)</p> <p><i>ACR 20</i> Etanercept 25 mg, 12 weeks: 22/30 (73%); placebo 12 weeks: 4/30 (13%); $p < 0.0001$</p> <p><i>ACR 50</i> Etanercept 25 mg, 12 weeks: 15/30 (50%); placebo 12 weeks: 1/30 (3%); $p = 0.0001$</p> <p><i>ACR 70</i> Etanercept 25 mg, 12 weeks: 4/30 (13%); placebo 12 weeks: 0/30 (0%); $p = 0.0403$</p> <p><i>PsARC</i> Etanercept 25 mg, 4 weeks: 23/30 (77%); placebo 4 weeks: 4/30 (14%); $p < 0.0001$ Etanercept 25 mg, 8 weeks: 25/30 (83%); placebo 4 weeks: 8/30 (27%); $p < 0.0001$ Etanercept 25 mg, 12 weeks: 26/30 (87%); placebo 12 weeks: 7/30 (23%); $p < 0.0001$</p> <p><i>HAQ</i> Median (25th and 75th percentiles): Etanercept 25 mg, baseline 1.3 (CiC information has been removed), 12 weeks 0.1 (CiC information has been removed) Placebo baseline 1.2 (CiC information has been removed), 12 weeks 1.1 (CiC information has been removed); $p < 0.001$ (at 12 weeks)</p> <p>Mean (SD): Etanercept 25 mg, baseline 1.2 (CiC information has been removed), 12 weeks 0.5 (CiC information has been removed) Placebo baseline 1.2 (CiC information has been removed), 12 weeks 1.1 (CiC information has been removed)</p> <p>Percentage improvement at 12 weeks (mean, SD): Etanercept 25 mg ($n = 29$) 64.2 (CiC information has been removed) Placebo ($n = 30$) 9.9 (CiC information has been removed)</p> <p>Median (range) PASI at baseline Etanercept 25 mg = 10.1 (2.3–30.0) Placebo = 6.0 (1.5–17.7)</p> <p><i>PASI 50</i> Etanercept 25 mg, 12 weeks: 8/19 (42%) Placebo 12 weeks: 4/19 (21%) Treatment difference $p = 0.295$</p>

continued

Study details and design	Participant details	Intervention/outcome/analyses details	Results
	<p><i>PsA history</i></p> <p>Duration of PsA (median, range):</p> <p>Etanercept 9.0 years (1.0–31.0 years)</p> <p>Placebo: 9.5 years (1.0–30.0 years)</p> <p><i>Psoriasis history</i></p> <p>Duration of psoriasis (median, range):</p> <p>Etanercept 19.0 years (4.0–53.0 years)</p> <p>Placebo: 17.5 years (2.0–43.0 years)</p> <p><i>Psoriasis evaluation</i></p> <p>Patients with $\geq 3\%$ BSA affected with psoriasis:</p> <p>Etanercept: 19/30 (63%)</p> <p>Placebo: 19/30 (63%)</p> <p><i>Concurrent therapies</i></p> <p>Patients taking a stable dose of MTX (≤ 25 mg/week) were permitted to continue with that dose if it had been stable for 4 weeks prior to study entry and remained constant during the study. Corticosteroids were allowed during the study at a dose of ≤ 10 mg/day prednisolone if the dose had been stable at study entry and if it was maintained during the trial</p> <p><i>Concomitant therapy during trial</i></p> <p>Corticosteroids:</p> <p>Etanercept group 6/30 (20%)</p> <p>Placebo group 12/30 (40%)</p> <p>NSAIDs:</p> <p>Etanercept group 20/30 (67%)</p> <p>Placebo group 23/30 (77%)</p> <p>MTX:</p> <p>Etanercept group 14/30 (47%)</p> <p>Placebo group 14/30 (47%)</p>	<p><i>Statistical analyses</i></p> <p>Proportions of patients' responding were compared using the Mantel–Haenszel chi-squared test adjusted for MTX use. Continuous variables were ranked and analysed by a general linear model with factors of treatment, MTX use and their interaction. The Breslow–Day test was used to test for heterogeneity of relative response between MTX use strata. The LOCF approach was used for imputing missing data</p> <p><i>ITT analysis</i></p> <p>All randomised patients were included in the analysis</p>	<p><i>PASI 75</i></p> <p>Etanercept 25 mg, 12 weeks: 5/19 (26%)</p> <p>Placebo 12 weeks: 0/19 (0%); $p=0.0154$</p> <p><i>100% improvement in physician global assessment</i></p> <p>Etanercept 25 mg, 12 weeks: 6/30 (20%)</p> <p>Placebo 12 weeks: 0/30 (0%)</p> <p><i>100% improvement in patient global assessment</i></p> <p>Etanercept 25 mg, 12 weeks: 5/30 (17%)</p> <p>Placebo 12 weeks: 0/30 (0%)</p> <p><i>ADVERSE EVENTS (STAGE 1, RANDOMISED)</i></p> <p><i>Infectious adverse events (n, %)</i></p> <p>[Placebo (P), $n=30$; etanercept (E), $n=30$]</p> <p>Respiratory tract infection: P, 4 (13%); E, 8 (27%)</p> <p>Pharyngitis: P, 3 (10%), E, 5 (17%)</p> <p>Rhinitis: P, 4 (13%); E, 6 (20%)</p> <p>Sinusitis: P, 2 (7%); E, 3(10%)</p> <p>Influenza syndrome: P, 6 (20%); E, 0</p> <p><i>Infections that required hospitalisation or i.v. antibiotics</i></p> <p>Etanercept: 0</p> <p>Placebo: 0</p> <p><i>Cancer: Not reported</i></p> <p><i>Reactivation of latent TB: Not reported</i></p> <p><i>Deaths: None</i></p> <p><i>Withdrawals due to adverse events: None</i></p> <p><i>EFFICACY OUTCOMES (STAGE 2, OPEN LABEL)</i></p> <p><i>PsARC</i></p> <p>Etanercept 25 mg, 16 weeks: 26/30 (87%); placebo/etanercept 16 weeks: 19/28 (68%)</p> <p>Etanercept 25 mg, 36 weeks: 26/30 (87%); placebo/etanercept 36 weeks: 21/28 (75%)</p> <p><i>ACR 20</i></p> <p>Etanercept 25 mg, 16 weeks: 22/30 (73%); placebo/etanercept 16 weeks: 12/28 (43%)</p> <p>Etanercept 25 mg, 36 weeks: 26/30 (87%); placebo/etanercept 36 weeks: 17/28 (61%)</p> <p><i>ACR 50</i></p> <p>Etanercept 25 mg, 16 weeks: 13/30 (43%); placebo/etanercept 16 weeks: 8/28 (29%)</p> <p>Etanercept 25 mg, 36 weeks: 19/30 (63%); placebo/etanercept 36 weeks: 13/28 (46%)</p> <p><i>ACR 70</i></p> <p>Etanercept 25 mg, 16 weeks: 7/30 (23%); placebo/etanercept 16 weeks: 0/28</p> <p>Etanercept 25 mg, 36 weeks: 10/30 (33%); placebo/etanercept 36 weeks: 7/28 (25%)</p> <p><i>HAQ</i></p> <p>(CiC information has been removed)</p>

Study details and design	Participant details	Intervention/outcome/analyses details	Results
<p>Mease, 2004, USA^{52,97,99,105,107,110}</p> <p><i>Type of publication:</i> Full publication</p> <p><i>Funding:</i> Immunex Corporation</p> <p><i>Study design:</i> Stage 1: Double-blind placebo-controlled RCT Stage 2: Maintenance period Stage 3: Open-label follow-up</p> <p><i>Duration of follow-up:</i> Stage 1: 24 weeks Stage 2: <24 weeks Stage 3: 48 weeks</p>	<p><i>Inclusion criteria:</i> Patients between 18 and 70 years of age with active PsA and stable plaque psoriasis (target lesion > 2-cm diameter) with more than three swollen joints and more than tender joints. Patients had at least one of the following subtypes of PsA: DIP joint involvement, polyarticular arthritis, arthritis mutilans, asymmetric peripheral arthritis, or ankylosing spondylitis-like arthritis. Patients taking a stable dose of MTX (≤ 25 mg/week) for 2 months were permitted to continue with that dose. Other DMARDs were discontinued at least 4 weeks prior to the trial</p>	<p><i>Intervention: etanercept</i></p> <p>Stage 1: Dose regimen: 25 mg s.c. twice per week Duration/frequency of treatment: 24 weeks No. of participants: 101</p> <p>Stage 2: After completing stage 1, patients could chose to continue on their blinded study treatment in this maintenance period until all patients had completed 24 weeks of study treatment and the database was locked Dose regimen: 25 mg s.c. twice per week Duration/frequency of treatment: < 24 weeks (CiC information has been removed)</p>	<p><i>PASI (patients evaluable for psoriasis only)</i></p> <p>PASI 50: Etanercept 25 mg, 36 weeks: 11/19 (58%); placebo/etanercept 36 weeks: 10/18 (56%)</p> <p>PASI 75: Etanercept 25 mg, 36 weeks: 7/19 (37%); placebo/etanercept 36 weeks: 5/18 (28%).</p> <p><i>ADVERSE EVENT OUTCOMES (STAGE 2, OPEN LABEL, 24 WEEKS)</i></p> <p>[Placebo (P), $n=28$; etanercept (E), $n=30$]</p> <p><i>Infectious adverse events, including any serious infections occurring in >5% of patients by treatment:</i></p> <p>Respiratory tract infection: P, 9 (32%); E, 7 (23%) Pharyngitis: P, 2 (7%); E, 1 (3%) Influenza syndrome: P, 4 (14%); E, 3 (10%) Urinary tract infection: P, 2 (7%); E, 0 Infection (not specified) : P, 0; E, 2 (7%)</p> <p><i>Cancer: None</i></p> <p><i>Other non-infectious serious adverse events:</i> (CiC information has been removed)</p> <p><i>Deaths:</i> (CiC information has been removed)</p> <p><i>Withdrawals due to adverse events:</i> (CiC information has been removed)</p> <p><i>Comments:</i> All efficacy data in Stage 2 relates to non-randomised patients. All patients in Stage 2 had received etanercept</p> <p><i>STAGE 1: EFFICACY OUTCOMES</i></p> <p><i>PsARC</i></p> <p>Etanercept 25 mg 4 weeks: 57 (56%); placebo 4 weeks: 25 (24%); $p < 0.001$</p> <p>Etanercept 25 mg 12 weeks: 73 (72%); placebo 12 weeks: 32 (31%); $p < 0.001$</p> <p>Etanercept 25 mg 24 weeks: 71 (70%); placebo 24 weeks: 24 (23%); $p < 0.001$</p> <p>Subgroup analysis (with and without MTX): Etanercept + MTX 12 weeks: 32/42 (76%); placebo 12 weeks: 14/43 (33%) Etanercept – MTX 12 weeks: 41/59 (69%); placebo 12 weeks: 18/61 (30%) Etanercept + MTX 24 weeks: 31/42 (74%); placebo 24 weeks: 11/43 (26%) Etanercept – MTX 24 weeks: 40/59 (68%); placebo 24 weeks: 13/61 (21%)</p> <p><i>ACR 20</i></p> <p>Etanercept 25 mg 4 weeks: 38 (38%); placebo 4 weeks: 11 (11%); $p < 0.001$</p> <p>Etanercept 25 mg 12 weeks: 60 (59%); placebo 12 weeks: 16 (15%); $p < 0.001$</p> <p>Etanercept 25 mg 24 weeks: 50 (50%); placebo 24 weeks: 14 (13%); $p < 0.001$</p> <p>Subgroup analysis (with and without MTX): Etanercept + MTX 12 weeks: 26/42 (62%); placebo 12 weeks: 8/43 (19%) Etanercept – MTX 12 weeks: 34/59 (58%); placebo 12 weeks: 8/61 (13%) Etanercept + MTX 24 weeks: 23/42 (55%); placebo 24 weeks: 8/43 (19%) Etanercept – MTX 24 weeks: 27/59 (46%); placebo 24 weeks: 6/61 (10%)</p>

continued

Study details and design	Participant details	Intervention/outcome/analyses details	Results
<p><i>Frequency of follow-up:</i></p> <p>Stage 1: Baseline, 4, 12 and 24 weeks</p> <p>Stage 2: 12-week intervals thereafter</p> <p>Stage 3: 48 weeks</p> <p><i>Extracted by:</i> HY</p> <p><i>Checked by:</i> MR</p>	<p>Corticosteroids were allowed during the study at a dose of ≤ 10 mg/day of prednisone if it was stable for at least 4 weeks prior to the trial.</p> <p>For patients with skin involvement psoriasis, phototherapy therapies had to be discontinued prior to the trial</p> <p>Oral retinoids, tropical vitamin A or D-analogue preparations, and dithranol were not allowed. Tropical therapies were only permitted on the scalp, axillae and groin</p> <p><i>No. randomised and treated</i></p> <p>Stage 1: 205 (CiC information has been removed)</p> <p>Stage 3: 168</p> <p><i>Age (mean)</i></p> <p>Etanercept: 47.6 years Placebo: 47.3 years</p> <p><i>Gender</i></p> <p>Etanercept: male 58/101(57%) Placebo: male 47/104 (45%)</p> <p><i>PsA history</i></p> <p>Duration of PsA, mean: Etanercept: 9.0 years Placebo: 9.2 years</p> <p><i>Psoriasis history</i></p> <p>Duration of psoriasis, mean: Etanercept: 18.3 years Placebo: 19.7 years</p> <p><i>Psoriasis evaluation</i></p> <p>Patients with $\geq 3\%$ BSA affected with psoriasis: Etanercept: 66/101 (65%) Placebo: 62/104 (60%)</p>	<p>Stage 3:</p> <p>After the database was locked all patients (CiC information has been removed) were eligible to enter a 48-week open-label extension</p> <p>Dose regimen: (CiC information has been removed)</p> <p>Duration/frequency of treatment: 48 weeks</p> <p>No. of participants: 168 (87 previously on etanercept; 81 stage 1 previously on placebo) (CiC information has been removed)</p> <p><i>Comparator: placebo</i></p> <p>Stage 1: Placebo ($n=104$): equivalent</p> <p>Stage 2: Placebo ($n=59$): equivalent</p> <p><i>Primary outcome</i></p> <p>The proportion of patients meeting the ACR 20 at 24 weeks</p> <p><i>Sample size calculation</i></p> <p>Assuming that an ACR 20 rate of 60% on etanercept and 30% on placebo, a sample size of 100 patients per group gives a power of 90% power to detect a significant difference between treatments in the primary outcome, with $\alpha=0.05$ (two-sided)</p> <p><i>Statistical analyses</i></p> <p>Binary response rates were compared using the Cochran–Mantel–Haenszel test or Fisher’s exact test. Continuous variables were analysed by Wilcoxon rank-sum test, using LOCF for missing data or early termination</p> <p><i>ITT analysis</i></p> <p>All randomised patients who received at least one dose of blinded study drug were included in the analysis</p>	<p><i>ACR 50</i></p> <p>Etanercept 25 mg 4 weeks: 11 (11%); placebo 4 weeks: 2 (2%); $p=0.009$</p> <p>Etanercept 25 mg 12 weeks: 38 (38%); placebo 12 weeks: 4 (4%); $p<0.001$</p> <p>Etanercept 25 mg 24 weeks: 37 (37%); placebo 24 weeks: 4 (4%); $p<0.001$</p> <p>Subgroup analysis (with and without MTX):</p> <p>Etanercept + MTX 12 weeks: 17/42 (40%); placebo 12 weeks: 1/43 (2%)</p> <p>Etanercept – MTX 12 weeks: 21/59 (36%); placebo 12 weeks: 3/61 (5%)</p> <p>Etanercept + MTX 24 weeks: 16/42 (38%); placebo 24 weeks: 3/43 (7%)</p> <p>Etanercept – MTX 24 weeks: 21/59 (36%); placebo 24 weeks: 1/61 (2%)</p> <p><i>ACR 70</i></p> <p>Etanercept 25 mg 4 weeks: 1 (1%); placebo 4 weeks: 0; $p=0.493$</p> <p>Etanercept 25 mg 12 weeks: 11 (11%); placebo 12 weeks: 0; $p<0.001$</p> <p>Etanercept 25 mg 24 weeks: 9 (9%); placebo 24 weeks: 1 (1%); $p=0.009$</p> <p>Subgroup analysis (with and without MTX)</p> <p>Etanercept + MTX 12 weeks: 4/42 (10%); placebo 12 weeks: 0/43 (0%)</p> <p>Etanercept – MTX 12 weeks: 7/59 (12%); placebo 12 weeks: 0/61 (0%)</p> <p>Etanercept + MTX 24 weeks: 2/42 (5%); placebo 24 weeks: 0/43 (0%)</p> <p>Etanercept – MTX 24 weeks: 7/59 (12%); placebo 24 weeks: 0/61 (0%)</p> <p><i>HAQ</i></p> <p>Mean (SD) absolute values:</p> <p>Etanercept 25 mg, baseline ($n=101$) 1.1 (CiC information has been removed); placebo baseline ($n=104$) 1.1 (CiC information has been removed)</p> <p>Etanercept 25 mg, 4 weeks ($n=101$) 0.7 (CiC information has been removed); placebo 4 weeks ($n=104$) 1.0 (CiC information has been removed)</p> <p>Etanercept 25 mg, 12 weeks ($n=101$) 0.6 (CiC information has been removed); placebo 12 weeks ($n=104$) 1.0 (CiC information has been removed)</p> <p>Etanercept 25 mg, 24 weeks ($n=101$) 0.5 (CiC information has been removed); placebo 24 weeks ($n=104$) 1.0 (CiC information has been removed)</p> <p>Mean (SD) % changes from baseline:</p> <p>Etanercept 25 mg, 4 weeks ($n=96$) 35.1 (CiC information has been removed); placebo 4 weeks ($n=99$) 8.0 (CiC information has been removed); $p<0.001$</p> <p>Etanercept 25 mg, 12 weeks ($n=96$) 53.5 (CiC information has been removed); placebo 12 weeks ($n=99$) 6.3 (CiC information has been removed); $p<0.001$</p> <p>Etanercept 25 mg, 24 weeks ($n=96$) 53.6 (CiC information has been removed); placebo 24 weeks ($n=99$) 6.4 (CiC information has been removed); $p<0.001$</p>

Study details and design	Participant details	Intervention/outcome/analyses details	Results
	<p><i>Concurrent therapies</i></p> <p>Concomitant therapy at baseline:</p> <p>MTX: etanercept 42/101 (42%); placebo 43/104 (41%)</p> <p>Corticosteroids: etanercept 19/101 (19%); placebo 16/104 (15%)</p> <p>NSAIDs: etanercept 89/101(88%); placebo 86/104(83%)</p>	<p><i>Comments</i></p> <p>Patients receiving MTX were randomised separately</p>	<p><i>TOTAL SHARP SCORE</i></p> <p>Mean (SD) annualised rate of progression at 6 months: Etanercept ($n=101$) -0.03 (0.73); placebo ($n=104$) 0.53 (1.39); $p=0.0006$</p> <p>Subgroup analysis (with and without MTX) (mean, SD):</p> <p>Etanercept + MTX ($n=42$) (CiC information has been removed); placebo ($n=43$) (CiC information has been removed)</p> <p>Etanercept – MTX ($n=59$) (CiC information has been removed); placebo ($n=61$) (CiC information has been removed)</p> <p>Mean PASI score at baseline: (CiC information has been removed)</p> <p><i>PASI 50</i></p> <p>No. (%) improvement in PASI 50:</p> <p>Etanercept 25 mg, 24 weeks ($n=66$): 31 (47%); placebo 24 weeks ($n=62$): 11 (18%); $p<0.001$</p> <p><i>PASI 75</i></p> <p>No. (%) improvement in PASI 75:</p> <p>Etanercept 25 mg 24 weeks ($n=66$): 15 (23%); placebo 24 weeks ($n=62$): 2 (3%); $p=0.001$</p> <p><i>PASI 90</i></p> <p>No. (%) improvement in PASI 90:</p> <p>Etanercept 25 mg, 24 weeks ($n=66$): 4 (6%); placebo 24 weeks ($n=62$): 2 (3%); $p=0.681$</p> <p><i>Target lesion score</i></p> <p>No. (%) with 50% improvement from baseline:</p> <p>Etanercept 25 mg, 24 weeks ($n=101$): 43 (43%); placebo 24 weeks ($n=104$): 18 (17%); $p<0.001$</p> <p>No. (%) with 75% improvement from baseline:</p> <p>Etanercept 25 mg, 24 weeks ($n=101$): 22 (22%); placebo 24 weeks ($n=104$): 10 (10%); $p=0.017$</p> <p><i>Physician global assessment</i></p> <p>Mean (median) % improvement from baseline:</p> <p>Etanercept 25 mg, 4 weeks 36.0 (50.0); placebo 4 weeks 2.9 (0); $p<0.001$</p> <p>Etanercept 25 mg, 12 weeks 44.9 (50); placebo 12 weeks 0.3 (0); $p<0.001$</p> <p>Etanercept 25 mg, 24 weeks 47.2 (50); placebo 24 weeks 2.3 (0); $p<0.001$</p> <p><i>Patient global assessment</i></p> <p>Mean (median) % improvement from baseline:</p> <p>Etanercept 25 mg, 4 weeks 21.6 (25.0); placebo 4 weeks 1.3 (0); $p<0.001$</p> <p>Etanercept 25 mg, 12 weeks 36.1 (33.3); placebo 12 weeks -0.3 (0); $p<0.001$</p> <p>Etanercept 25 mg, 24 weeks 40.4 (50.0); placebo 24 weeks -3.9 (0); $p<0.001$</p> <p><i>SF-36 – physical component score</i></p> <p>Mean (median) % changes from baseline:</p> <p>Etanercept 25 mg, 4 weeks 5.8 (5.1); placebo 4 weeks 0.5 (0.7); $p<0.001$</p> <p>Etanercept 25 mg, 12 weeks 8.9 (6.8); placebo 12 weeks 1.2 (1.6); $p<0.001$</p>

continued

Study details and design	Participant details	Intervention/outcome/analyses details	Results
			<p>Etanercept 25 mg, 24 weeks 9.3 (7.7); placebo 24 weeks 0.7 (0.5); $p < 0.001$</p> <p><i>STAGE 1: ADVERSE EVENTS</i></p> <p><i>Infectious adverse events [n, (%) – after 24 weeks]</i> [Etanercept (E), $n = 101$; placebo (P), $n = 104$]</p> <p>Any infection: P, 40 (40%); E, 45 (43%)</p> <p>Upper respiratory infection: P, 21 (21%); E, 24 (23%)</p> <p>Sinusitis: P, 6 (6%); E, 8 (8%)</p> <p>Urinary tract infection: P, 6 (6%); E, 6 (6%)</p> <p><i>Infections that required hospitalisation or use of i.v. antibiotics</i></p> <p>Etanercept: 0/101</p> <p>Placebo: 1/104 (1 gastroenteritis)</p> <p><i>Cancer: None</i></p> <p><i>Reactivation of latent TB: Not reported</i></p> <p><i>Deaths (no. of patients)</i></p> <p>Etanercept: 0</p> <p>Placebo: one – surgery complications for perforated bowel</p> <p><i>Withdrawals due to adverse events (no. of patients)</i></p> <p>Etanercept: one – elevated liver enzymes</p> <p>Placebo: one – increased psoriasis</p> <p><i>STAGE 2: EFFICACY OUTCOMES</i></p> <p>Not reported</p> <p><i>STAGE 3: EFFICACY OUTCOMES</i></p> <p>ACR 20/50/70 responses were maintained or improved over the open follow-up stage of the trial in those patients who had taken etanercept from baseline. Data reported in graphical form only (not extractable)</p> <p><i>Radiographic results</i></p> <p><i>Total Sharp Score</i></p> <p>Mean (SD) annualised rate of progression at 12 months: Etanercept ($n = 101$) -0.03 (CiC information has been removed); placebo ($n = 104$) 1.00 (CiC information has been removed); $p = 0.0001$</p> <p>Subgroup analysis (with and without MTX) (mean, SD): (CiC information has been removed)</p> <p><i>Total Sharp Score excluding DIP joints</i></p> <p>Mean (SE) annualised rate of progression at 12 months (CiC information has been removed)</p> <p>Erosion score: mean rate of change (units/year): Etanercept ($n = 101$) -0.08; placebo ($n = 104$) 0.69; $p = 0.0001$</p> <p>Joint space narrowing: mean rate of change (units/year): Etanercept ($n = 101$) 0.06; placebo ($n = 104$) 0.35; $p = 0.04$</p> <p>PsA-specific radiographic features: (CiC information has been removed)</p> <p><i>STAGE 2: ADVERSE EVENTS</i> (CiC information has been removed)</p> <p><i>STAGE 3: ADVERSE EVENTS</i> (CiC information has been removed)</p> <p>Serious infection $n = 1$ (pneumonia)</p> <p><i>STAGE 2 AND STAGE 3 COMBINED: ADVERSE EVENTS</i> (CiC information has been removed)</p>

Efficacy data extraction: infliximab

Study details and design	Participant details	Intervention/outcome/analyses details	Results
<p>IMPACT, 2005, USA^{79-81,89,96,109,111,112-115,117,118}</p> <p><i>Type of publication:</i> Full publication</p> <p><i>Funding:</i> Centocor and Schering-Plough¹⁵²</p> <p><i>Study design:</i> Double-blind RCT with open uncontrolled extension</p> <p><i>Setting:</i> Outpatient, multicentre</p> <p><i>Duration of follow-up:</i> Stage 1: 16 weeks Stage 2: > 34 weeks</p> <p><i>Frequency of follow-up:</i> Stage 1: Baseline, 2, 6, 14 and 16 weeks Stage 2: 18, 22, 30, 46 and 50 weeks</p> <p><i>Extracted by:</i> HY</p> <p><i>Checked by:</i> MR</p>	<p><i>Inclusion/exclusion criteria</i></p> <p>Adults aged 18 years or above, diagnosed with PsA for at least 6 months, with negative results of the serum tests for RF. Patients must have active peripheral polyarticular arthritis (defined as five or more swollen and tender joints), with at least one of the following criteria: ESR \geq 28 mm/hour, CRP level \geq 15 mg/l, and/or morning stiffness lasting 45 minutes or longer.</p> <p>Patients must have failed to the treatment of at least one DMARD</p> <p><i>No. randomised:</i> 104</p> <p><i>Mean age (SD):</i> Infliximab: 45.7 years (11.1) Placebo: 45.2 years (9.7)</p> <p><i>Gender (% male):</i> Infliximab: 30/52 (57.7%) Placebo: 30/52 (57.7%)</p> <p><i>PsA history:</i> Mean (SD) duration: Infliximab: 11.7 years (9.8) Placebo: 11.0 years (6.6)</p> <p><i>Psoriasis history</i> Mean (SD) duration: Infliximab: 16.9 years (10.9) Placebo: 19.4 years (11.6)</p> <p><i>Psoriasis evaluation</i> Patients with baseline PASI \geq 2.5: Infliximab: 22/52 Placebo: 17/52</p>	<p><i>Intervention: infliximab</i></p> <p>Dose regimen: 5 mg/kg at weeks 0, 2, 6 and 14</p> <p>Length of treatment: 16 weeks</p> <p>No. randomised: 52 No. completed: 49</p> <p><i>Comparator: Placebo</i></p> <p>Dose regimen: Equivalent</p> <p>Length of treatment: 16 weeks</p> <p>No. randomised: 52 No. completed: 50</p> <p>Patients in the placebo group in Stage 1 received 5 mg/kg of infliximab at weeks 16, 18, 22, 30, 38 and 46. Patients that were in the infliximab group in Stage 1 received placebo at weeks 16 and 18, and 5 mg/kg of infliximab at weeks 22, 30, 38 and 46</p> <p><i>Primary outcome</i> ACR 20 at week 16</p> <p><i>Sample size calculation</i> Assuming an ACR 20 rate of 50% on infliximab and 20% on placebo, a sample size of 45 patients per group gave 80% power to detect a significant difference between treatments on the primary outcome, with $\alpha = 0.05$ (two-sided)</p> <p><i>Statistical analyses</i> Categorical outcomes (including ACR 20) were compared using the chi-squared test</p> <p>The Mantel-Haenszel test was conducted to estimate the ORs of the two treatment groups. Continuous outcomes were analysed using one-way ANOVA</p>	<p><i>STAGE 1: EFFICACY OUTCOMES</i></p> <p><i>ACR 20</i> Infliximab 14 weeks 67.3% (35/52); placebo 14 weeks 11.5% (6/52); $p < 0.01$ Infliximab 16 weeks 65.4% (34/52); placebo 16 weeks 9.6% (5/52); $p < 0.001$</p> <p><i>ACR 50</i> Infliximab 14 weeks 36.5% (19/52); placebo 14 weeks 1.9% (1/52); $p < 0.01$ Infliximab 16 weeks 46.2% (24/52); placebo 16 weeks 0% (0/52); $p < 0.001$</p> <p><i>ACR 70</i> Infliximab 14 weeks 21.2% (11/52); placebo 14 weeks 0% (0/52); $p < 0.01$ Infliximab 16 weeks 28.8% (15/52); placebo 16 weeks 0% (0/52); $p < 0.001$</p> <p><i>PsARC</i> Infliximab 14 weeks 76.9% (40/52); placebo 14 weeks 13.5% (7/52); $p < 0.01$ Infliximab 16 weeks 75% (39/52); placebo 16 weeks 21% (11/52); $p < 0.001$</p> <p><i>HAQ (mean, SD)</i> Infliximab baseline: 1.2 (0.7); placebo baseline = 1.2 (0.7) (CiC information has been removed)</p> <p><i>HAQ mean (SE) % change from baseline</i> Infliximab 16 weeks ($n = 48$) -49.8 (8.2); placebo 16 weeks ($n = 47$) 1.6 (8.3)</p> <p><i>Mean (SD) PASI at baseline for all patients measured</i> Infliximab ($n = 52$): 5.1 (5.9); placebo ($n = 52$) = 4.2 (5.8) (CiC information has been removed)</p> <p><i>PASI 50</i> Infliximab 16 weeks 100% (22/22); placebo 16 weeks 0% (0/16)</p> <p><i>PASI 75</i> Infliximab 16 weeks 68.2% (15/22); placebo 16 weeks 0% (0/16)</p> <p><i>PASI 90</i> Infliximab 16 weeks 36.4% (8/22); placebo 16 weeks 0% (0/16)</p> <p><i>Patient global assessment of disease mean (SE)</i> Infliximab 16 weeks -47.5 (7.4); placebo 16 weeks 13.9 (7.5); $p < 0.001$</p> <p><i>Physician global assessment of disease mean (SE)</i> Infliximab 16 weeks -58.4 (6.0); placebo 16 weeks 4.7 (6.0); $p < 0.001$</p> <p><i>STAGE 1: ADVERSE EVENTS</i></p> <p><i>Infectious adverse events including any serious infections</i> (Placebo, P; infliximab, I)</p> <p>Bronchitis: P, 4/51 (7.8%); I, 3/52 (5.8%) Rhinitis: P, 2/51 (3.9%); I, 3/52 (5.7%) Upper respiratory tract infection: P, 5/51 (9.8%); I, 1/52 (1.9%)</p>

continued

Study details and design	Participant details	Intervention/outcome/analyses details	Results
	<p><i>Concurrent therapies:</i> Patients receiving one on the following DMARDs were eligible; MTX, leflunomide, sulfasalazine, hydroxychloroquine, intramuscular gold, penicillamine, and azathioprine. Patients receiving a DMARD must have received a stable dosage for at least 4 weeks prior to the trial and throughout the investigation. Dosages of corticosteroids and NSAIDs were permitted to remain stable throughout the study if the dosages had been stable for at least 2 weeks prior to screening. Stable dose of topical treatment for psoriatic lesions (e.g. topical steroids) were also permitted. Therapy with PUVA was not permitted. Patients could not receive any investigational drug within 3 months of screening or any previous treatment with a monoclonal antibody or fusion protein</p> <p><i>Concomitant therapy at baseline</i></p> <p>Concomitant DMARD at baseline:</p> <p>Placebo 41/52 (79%)</p> <p>Infliximab 33/52 (63%)</p> <p><i>Note: the most commonly used DMARD was MTX</i></p>	<p><i>ITT analysis</i></p> <p>The analyses were performed on an ITT basis</p>	<p><i>Infections that required hospitalisation or use of i.v. antibiotics:</i> Not reported</p> <p><i>Non-infectious adverse events</i></p> <p>Infliximab: one – synovitis (culture negative)</p> <p>Placebo: one – rectal bleeding due to diverticulitis</p> <p><i>Cancer:</i> None</p> <p><i>Reactivation of latent TB:</i> None</p> <p><i>Deaths:</i> Not reported</p> <p><i>Withdrawals due to adverse events (no. of patients):</i> Not reported</p> <p>STAGE 2: EFFICACY OUTCOMES</p> <p><i>ACR 20 response</i></p> <p>Infliximab 18 weeks 77.6% (38/49); placebo/infliximab 18 weeks 52.0% (26/50)</p> <p>Infliximab 22 weeks 71.4% (35/49); placebo/infliximab 22 weeks 62.0% (31/50)</p> <p>Infliximab 30 weeks 65.3% (32/49); placebo/infliximab 30 weeks 66.0% (33/50)</p> <p>Infliximab 38 weeks 57.1% (28/49); placebo/infliximab 38 weeks 62.0% (31/50)</p> <p>Infliximab 46 weeks 57.1% (28/49); placebo/infliximab 46 weeks 66.0% (33/50)</p> <p>Infliximab 50 weeks 69.4% (34/49); placebo/infliximab 50 weeks 68.0% (34/50)</p> <p>Subgroup results (baseline MTX or no baseline MTX) at 50 weeks: (CiC information has been removed)</p> <p><i>ACR 50 response</i></p> <p>Infliximab 18 weeks 49.0% (24/49); placebo/infliximab 18 weeks 26.0% (13/50)</p> <p>Infliximab 22 weeks 38.8% (19/49); placebo/infliximab 22 weeks 36.0% (18/50)</p> <p>Infliximab 30 weeks 42.9% (21/49); placebo/infliximab 30 weeks 44.0% (22/50)</p> <p>Infliximab 38 weeks 40.8% (20/49); placebo/infliximab 38 weeks 48.0% (24/50)</p> <p>Infliximab 46 weeks 49.0% (24/49); placebo/infliximab 46 weeks 46.0% (23/50)</p> <p>Infliximab 50 weeks 53.1% (26/49); placebo/infliximab 50 weeks 42.0% (21/50)</p> <p><i>ACR 70 response</i></p> <p>Infliximab 18 weeks 28.6% (14/49); placebo/infliximab 18 weeks 8.0% (4/50)</p> <p>Infliximab 22 weeks 22.4% (11/49); placebo/infliximab 22 weeks 20.0% (10/50)</p> <p>Infliximab 30 weeks 26.5% (13/49); placebo/infliximab 30 weeks 22.0% (11/50)</p> <p>Infliximab 38 weeks 26.5% (13/49); placebo/infliximab 38 weeks 28.0% (14/50)</p> <p>Infliximab 46 weeks 32.7% (16/49); placebo/infliximab 46 weeks 24.0% (12/50)</p> <p>Infliximab 50 weeks 38.8% (19/49); placebo/infliximab 50 weeks 34.0% (17/50)</p> <p><i>Mean (SD) % ACR improvement</i></p> <p>(CiC information has been removed)</p>

Study details and design	Participant details	Intervention/outcome/analyses details	Results
			<p><i>PsARC</i></p> <p>Infliximab 18 weeks 81.6% (40/49); placebo/infliximab 18 weeks 70.0% (35/50)</p> <p>Infliximab 22 weeks 77.6% (38/49); placebo/infliximab 22 weeks 74.0% (37/50)</p> <p>Infliximab 30 weeks 73.5% (36/49); placebo/infliximab 30 weeks 78.0% (39/50)</p> <p>Infliximab 38 weeks 71.4% (35/49); placebo/infliximab 38 weeks 82.0% (41/50)</p> <p>Infliximab 46 weeks 69.4% (34/49); placebo/infliximab 46 weeks 74.0% (37/50)</p> <p>Infliximab 50 weeks 73.5% (36/49); placebo/infliximab 50 weeks 76.0% (38/50)</p> <p><i>HAQ (0–3)</i></p> <p>(CiC information has been removed)</p> <p><i>HAQ (0–3) mean (SE) % change from baseline</i></p> <p>Infliximab 50 weeks ($n=45$) -42.5 (8.8); (CiC information has been removed)</p> <p><i>Change in PASI mean (SE) change from baseline</i></p> <p>Infliximab 50 weeks ($n=35$) -4.8 (1.0); placebo/infliximab 50 weeks ($n=37$) -2.7 (1.0)</p> <p><i>PASI 50</i></p> <p>Infliximab 86.3% (19/22); placebo/infliximab 68.8% (11/16)</p> <p><i>PASI 75</i></p> <p>Infliximab 59.1% (13/22); placebo/infliximab 50% (8/16)</p> <p><i>PASI 90</i></p> <p>Infliximab 40.9% (9/22); placebo/infliximab 37.5% (6/16)</p> <p><i>Mean (SD) total modified van der Heijde–Sharp score</i></p> <p>Baseline:</p> <p>Infliximab ($n=37$), 69.2 (94.9); placebo/infliximab ($n=35$), 32.3 (39.7)</p> <p>Week 50 change from baseline:</p> <p>Infliximab ($n=37$), -1.52 (NR); placebo/infliximab ($n=33$), -1.95 (NR); combined ($n=70$) -1.72 (5.82)</p> <p><i>STAGE 2: ADVERSE EVENTS</i></p> <p>(CiC information has been removed)</p> <p>Serious infection: one patient on infliximab/placebo – <i>Salmonella</i> infection</p>

continued

Study details and design	Participant details	Intervention/outcome/analyses details	Results
<p>IMPACT 2, 2005, USA^{82,90,91,95,98,106,112,116}</p> <p><i>Type of publication:</i> Full publication</p> <p><i>Funding:</i> Centocor and Schering-Plough¹⁵²</p> <p><i>Study design:</i> Double-blind RCT and open-label extension</p> <p><i>Setting:</i> Outpatient, multicentre</p> <p><i>Duration of follow-up:</i></p> <p>Stage 1: 24 weeks RCT</p> <p>Stage 2: Open-label follow-up to 54 weeks</p> <p><i>Frequency of follow-up:</i></p> <p>Baseline, 2, 6, 14, 24 and 54 weeks</p> <p><i>Extracted by:</i> HY</p> <p><i>Checked by:</i> MR</p>	<p><i>Inclusion/exclusion criteria</i></p> <p>Adult patients diagnosed with active PsA at least 6 months before the first infusion of infliximab, with five or more swollen and tender joints and either CRP of ≥ 15 mg/l and/or morning stiffness lasting 45 minutes or longer. Patient must have had an inadequate response to current or previous DMARDs or NSAIDs. Patient had a negative RF and active plaque psoriasis with at least one qualifying target lesion (≥ 2-cm diameter)</p> <p><i>No. randomised:</i> 200</p> <p><i>Mean age (SD)</i></p> <p>Infliximab: 47.1 years (12.8)</p> <p>Placebo: 46.5 years (11.3)</p> <p><i>Gender (% male)</i></p> <p>Infliximab: 71%</p> <p>Placebo: 51%</p> <p><i>PsA history</i></p> <p>Mean (SD) duration:</p> <p>Infliximab: 8.4 years (7.2)</p> <p>Placebo: 7.5 years (7.8)</p> <p><i>Psoriasis history</i></p> <p>Mean (SD) duration:</p> <p>Infliximab: 16.8 years (12.0)</p> <p>Placebo: 16.2 years (11.0)</p> <p><i>Psoriasis evaluation</i></p> <p>Patients with $\geq 3\%$ BSA affected with psoriasis:</p> <p>Infliximab: 83/100 (83%)</p> <p>Placebo: 87/100 (87%)</p>	<p><i>Intervention: infliximab</i></p> <p>Dose regimen: 5 mg/kg at weeks 0, 2, 6, 14, and 22</p> <p>Length of treatment: 24 weeks</p> <p>No. randomised: 100</p> <p>No. completed: 93</p> <p><i>Comparator: placebo</i></p> <p>Dose regimen: equivalent</p> <p>Length of treatment: 24 weeks</p> <p>No. randomised: 100</p> <p>No. completed: 92</p> <p>Further infusions of infliximab were administered to all patients in an open-label fashion (timing dependent upon whether they were originally randomised to infliximab, or crossed over from placebo at either week 16 or 24) with further follow-up at week 54</p> <p><i>Primary outcome</i></p> <p>ACR 20 at week 14</p> <p><i>Sample size calculation:</i></p> <p>Assuming that an ACR 20 rate of 42% on infliximab and 20% on placebo, a sample size of 100 patients per group gives 90% power to detect a significant difference between treatments on the primary outcome, with $\alpha = 0.05$ (two-sided).</p> <p><i>Statistical analyses</i></p> <p>Cochran–Mantel–Haenszel chi-squared test stratified by baseline MTX use was used to analyse categorical outcomes. A two-sided <i>F</i>-test using ANOVA with baseline MTX as a factor was used to analyse continuous data. The LOCF approach was used for imputing missing data</p> <p><i>ITT analysis</i></p> <p>The analyses were performed on an ITT basis</p>	<p><i>STAGE 1: EFFICACY OUTCOMES</i></p> <p><i>ACR 20</i></p> <p>Infliximab 14 weeks: 58% (58/100); placebo 14 weeks: 11% (11/100); $p < 0.001$</p> <p>Infliximab 24 weeks: 54% (54/100); placebo 24 weeks = 16% (16/100); $p < 0.001$</p> <p><i>ACR 50</i></p> <p>Infliximab 14 weeks: 36% (36/100); placebo 14 weeks = 3% (3/100); $p < 0.001$</p> <p>Infliximab 24 weeks: 41% (41/100); placebo 24 weeks: 4% (4/100); $p < 0.001$</p> <p><i>ACR 70</i></p> <p>Infliximab 14 weeks: 15% (15/100); placebo 14 weeks = 1% (1/100); $p < 0.001$</p> <p>Infliximab 24 weeks: 27% (27/100); placebo 24 weeks: 2% (2/100); $p < 0.001$</p> <p><i>PsARC</i></p> <p>Infliximab 14 weeks: 77% (77/100); placebo 14 weeks: 27% (27/100); $p < 0.001$</p> <p>Infliximab: 24 weeks = 70% (70/100); placebo 24 weeks: 32% (32/100); $p < 0.001$</p> <p><i>Mean (SD) HAQ at baseline</i></p> <p>Infliximab = 1.1 (0.6); placebo = 1.1 (0.6)</p> <p><i>HAQ % change from baseline (SD)</i></p> <p>Infliximab 14 weeks: 48.6 (43.3); placebo 14 weeks: -18.4 (90.5); $p < 0.001$</p> <p>Infliximab 24 weeks: 46.0 (42.5); placebo 24 weeks: -19.4 (102.8); $p < 0.001$</p> <p><i>HAQ improvement (≥ 0.3 decrease)</i></p> <p>Infliximab 14 weeks: 59%; placebo 14 weeks: 19%; $p < 0.001$</p> <p>Infliximab 24 weeks: 52%; placebo 24 weeks: 20%; $p < 0.001$</p> <p><i>PASI 50 (in patients with $\geq 3\%$ BSA psoriasis)</i></p> <p>Infliximab 14 weeks: 82% (68/83); placebo 14 weeks: 9% (8/87); $p < 0.001$</p> <p>Infliximab 24 weeks: 75% (62/83); placebo 24 weeks: 8% (7/87); $p < 0.001$</p> <p><i>PASI 75 (in patients with $\geq 3\%$ BSA psoriasis)</i></p> <p>Infliximab 14 weeks: 64% (53/83); placebo 14 weeks: 2% (2/87); $p < 0.001$</p> <p>Infliximab 24 weeks: 60% (50/83); placebo 24 weeks: 1% (1/87); $p < 0.001$</p> <p><i>PASI 90 (in patients with $\geq 3\%$ BSA psoriasis)</i></p> <p>Infliximab 14 weeks: 41% (34/83); placebo 14 weeks: 0% (0/87); $p < 0.001$</p> <p>Infliximab 24 weeks: 39% (32/83); placebo 24 weeks: 0% (0/87); $p < 0.001$</p> <p><i>PASI 50 (in patients with PASI ≥ 2.5 at baseline)</i></p> <p>(CiC information has been removed)</p> <p><i>PASI 75 (in patients with PASI ≥ 2.5 at baseline)</i></p> <p>(CiC information has been removed)</p> <p><i>PASI 90 (in patients with PASI ≥ 2.5 at baseline)</i></p> <p>(CiC information has been removed)</p>

Study details and design	Participant details	Intervention/outcome/analyses details	Results
	<p><i>Concurrent therapies:</i> Concomitant MTX (up to 25 mg/week) was permitted at least 3 months prior to the first infusion and was maintained at a stable dose for at least 4 weeks prior to first infusion. A stable dose (10 mg) of oral prednisone was permitted. DMARDs or intra-articular corticosteroids were prohibited within 4 weeks before the first infusion. DMARDs other than MTX were not permitted during the trial. Systematic or topical treatment for psoriasis was not permitted (except for low potency topical corticosteroids on face or groin)</p>		<p><i>Mean (SD) SF-36 at baseline</i></p> <p>Physical component: Infliximab = 33.0 (9.4); placebo = 31.0 (9.0)</p> <p>Mental component: Infliximab = 45.5 (11.9); placebo = 47.0 (11.9)</p> <p><i>SF-36 mean change from baseline (SD)</i></p> <p>Physical component: Infliximab 14 weeks: 9.1 (9.3); placebo 14 weeks = 1.1 (8.4); $p < 0.001$ Infliximab 24 weeks: 7.7 (9.8); placebo 24 weeks: 1.3 (8.2); $p = 0.001$</p> <p>Mental component: Infliximab 14 weeks: 3.8 (11.1); placebo 14 weeks: -1.2 (9.3); $p < 0.001$ Infliximab 24 weeks: 3.9 (11.9); placebo 24 weeks: 0.4 (11.6); $p = 0.05$</p> <p><i>Mean (SD) total modified van der Heijde-Sharp score</i></p> <p>Week 24 change from baseline: Infliximab -0.70 (2.53); placebo 0.82 (2.62)</p> <p>STAGE 1: ADVERSE EVENTS</p> <p><i>Infectious adverse events, including any serious infections (up to week 24)</i></p> <p>[Placebo (P), $n = 97$; infliximab (I), all patients who received an infliximab dose, $n = 150$]</p> <p>Upper respiratory tract infection: P, 14 (14%); I, 15 (10%) Pharyngitis: P, 4 (4%); I, 8 (5%) Sinusitis: P, 4 (4%); I, 8 (5%)</p> <p><i>Infections that required hospitalisation or use of i.v. antibiotics:</i> Not reported</p> <p><i>Malignancy</i></p> <p>Placebo: one – basal cell carcinoma of skin Infliximab: 0</p> <p><i>Reactivation of latent TB:</i> None</p> <p><i>Deaths:</i> None</p> <p><i>Total serious adverse events</i></p> <p>Placebo: 6 (6%) Infliximab: 13 (9%)</p> <p><i>Withdrawals due to adverse events (no. of patients)</i></p> <p>Infliximab: 6 Placebo: 1</p> <p>STAGE 2: EFFICACY OUTCOMES</p> <p><i>PsARC</i></p> <p>Infliximab 54 weeks: 74.4% (67/90); placebo/infliximab 54 weeks: 81.9% (68/83)</p> <p><i>PASI 50 (in patients with $\geq 3\%$ BSA psoriasis)</i></p> <p>Infliximab 54 weeks: 69.5% (57/82); placebo/infliximab 54 weeks: 80% (64/80)</p> <p><i>PASI 75 (in patients with $\geq 3\%$ BSA psoriasis)</i></p> <p>Infliximab 54 weeks: 48.8% (40/82); placebo/infliximab 54 weeks: 58.8% (47/80)</p>

continued

Study details and design	Participant details	Intervention/outcome/analyses details	Results
			<p><i>PASI 90 (in patients with $\geq 3\%$ BSA psoriasis)</i></p> <p>Infliximab 54 weeks: 39% (32/82); placebo/infliximab 54 weeks: 81.9% (68/80)</p> <p><i>Mean (SD) total modified van der Heijde–Sharp score</i></p> <p>Baseline:</p> <p>Infliximab 30.3 (61.4); placebo/infliximab 39.1 (82.8)</p> <p>Week 54 change from baseline:</p> <p>Infliximab -0.94 (3.4); placebo/infliximab 0.53 (2.6)</p> <p><i>STAGE 2: ADVERSE EVENTS</i></p> <p><i>Infectious adverse events including any serious infections (through week 54)</i></p> <p>Combined infliximab/placebo (all who received an infliximab dose, $n \geq 173$)</p> <p>(CiC information has been removed)</p> <p><i>Infections that required hospitalisation or use of i.v. antibiotics:</i> Not reported</p> <p><i>Malignancy:</i></p> <p>Two (one basal cell carcinoma, one Hodgkin’s lymphoma)</p> <p><i>Reactivation of latent TB:</i> None</p> <p><i>Deaths:</i> None</p> <p><i>Total serious adverse events:</i> 22 (11.5%)</p> <p><i>Withdrawals due to adverse events (no. of patients):</i> 16 (8.4%)</p>

ANOVA, analysis of variance; PUVA, psoralen plus ultraviolet light, type A, treatment.

Efficacy data extraction: adalimumab

Study details and design	Participant details	Intervention/outcome/analyses details	Results
<p>ADEPT 2005, USA^{51,88,92,93,100-104}</p> <p><i>Type of publication:</i> Full publication</p> <p><i>Funding:</i> Abbott</p> <p><i>Study design:</i> Stage 1: Double-blind RCT Stage 2: Open-label extension</p> <p><i>Setting:</i> Outpatient</p> <p><i>Duration of follow-up:</i> Stage 1: 24 weeks Stage 2: 24–144 weeks</p> <p><i>Frequency of follow-up:</i> Baseline, 2, 4, 8, 12, 16, 20 and 24 weeks</p> <p><i>Extracted by:</i> HY</p> <p><i>Checked by:</i> MR</p>	<p><i>Inclusion/exclusion criteria:</i> Adults aged 18 years or above diagnosed with moderately or severely PsA (defined as ≥ 3 swollen and tender or painful joints). Patients must have either active psoriatic skin lesions or a documented history of psoriasis, with an adequate response or intolerance to NSAIDs.</p> <p>Patients were excluded if they had the following treatment: (1) within 4 weeks of the baseline visit with ciclosporin, tacrolimus, DMARDs other than MTX, or oral retinoids; (2) topical therapy for psoriasis within 2 weeks of baseline, other than medicated shampoos or low-potency topical steroids; (3) concurrent therapy with MTX at dosage > 30 mg/week and/or corticosteroids in a prednisone-equivalent dosage of > 10 mg/day; and (4) biologic therapy at any time</p> <p><i>No. randomised:</i> 315</p> <p><i>Mean age (SD)</i></p> <p>Adalimumab: 48.6 years (12.5)</p> <p>Placebo: 49.2 years (11.1)</p> <p><i>Gender (% male)</i></p> <p>Adalimumab: 85/151 (56.3%)</p> <p>Placebo: 89/162 (54.9%)</p> <p><i>PsA history</i></p> <p>Mean (SD) duration:</p> <p>Adalimumab: 9.8 years (8.3)</p> <p>Placebo: 9.2 years (8.7)</p>	<p><i>Intervention: adalimumab</i></p> <p>Dose regimen: 40 mg every other week</p> <p>Length of treatment: 24 weeks</p> <p>No. randomised: 153</p> <p>No. completed: 140</p> <p><i>Comparator: placebo</i></p> <p>Dose regimen: Equivalent</p> <p>Length of treatment: 24 weeks</p> <p>No. randomised: 162</p> <p>No. completed: 149</p> <p><i>Primary outcome</i></p> <p>ACR 20 at week 12 and the change in TSS of structural damage on radiographs of the hands and feet at week 24</p> <p><i>Sample size calculation</i></p> <p>Assuming that the effect size of anticipated change in the modified TSS is 0.325, the sample size of 150 per treatment group gave 80% power to detect a significant difference between treatments on this primary outcome, with $\alpha = 0.05$ (two-sided)</p> <p><i>Statistical analyses</i></p> <p>Proportions of patients responding were compared using the Cochran–Mantel–Haenszel mean score test adjusted for the MTX use. Continuous data were analysed by ANOVA with factors of treatment, baseline, MTX use and extent of psoriasis. Non-responder imputation was used, in which participants who discontinued or had missing data were counted as non-responders. Patients who received rescue therapy were considered to be non-responders at the time that rescue therapy was initiated</p>	<p><i>STAGE 1: EFFICACY OUTCOMES</i></p> <p><i>ACR 20</i></p> <p>Adalimumab 12 weeks: 58% (88/151); placebo 12 weeks: 14% (23/162); $p < 0.001$</p> <p>Adalimumab 24 weeks: 57% (86/151); placebo 24 weeks: 15% (24/162); $p < 0.001$</p> <p>Adalimumab + MTX 12 weeks: 55% (42/77); adalimumab alone 12 weeks: 61% (45/74); $p = 0.511$</p> <p>Adalimumab + MTX 24 weeks: 55% (42/77); adalimumab alone 24 weeks: 59% (44/74), $p = 0.622$</p> <p><i>ACR 50</i></p> <p>Adalimumab 12 weeks: 36% (54/151); placebo 12 weeks: 4% (6/162); $p < 0.001$</p> <p>Adalimumab 24 weeks: 39% (59/151); placebo 24 weeks: 6% (10/162); $p < 0.001$</p> <p>Adalimumab + MTX 12 weeks: 36% (28/77); Adalimumab alone 12 weeks: 36% (27/74), $p > 0.999$</p> <p>Adalimumab + MTX 24 weeks: 36% (28/77); Adalimumab alone 24 weeks: 42% (31/74), $p = 0.509$</p> <p><i>ACR 70</i></p> <p>Adalimumab 12 weeks: 20% (30/151); placebo 12 weeks: 1% (1/162); $p < 0.001$</p> <p>Adalimumab 24 weeks: 23% (35/151); placebo 24 weeks: 1% (1/162); $p < 0.001$</p> <p>Adalimumab + MTX 12 weeks: 17% (13/77); adalimumab alone 12 weeks: 23% (17/74); $p = 0.416$</p> <p>Adalimumab + MTX 24 weeks: 22% (17/77); adalimumab alone 24 weeks: 23% (17/74); $p > 0.999$</p> <p><i>PsARC</i></p> <p>Adalimumab 12 weeks: 62% (94/151); placebo 12 weeks: 26% (42/162)</p> <p>Adalimumab 24 weeks: 60% (91/151); placebo 24 weeks: 23% (37/162)</p> <p><i>Mean HAQ at baseline (SD)</i></p> <p>Adalimumab: 1.0 (0.6); placebo: 1.0 (0.7)</p> <p><i>HAQ mean change from baseline (SD)</i></p> <p>Adalimumab 12 weeks: $-0.4(0.5)$; placebo 12 weeks: $-0.1(0.5)$; $p < 0.001$</p> <p>Adalimumab 24 weeks: $-0.4(0.5)$; placebo 24 weeks: $-0.1(0.4)$; $p < 0.001$</p> <p>Adalimumab + MTX 12 weeks: $-0.3(0.4)$; adalimumab alone 12 weeks: $-0.4(0.5)$; $p = 0.188$</p> <p>Adalimumab + MTX 24 weeks: $-0.4(0.5)$; adalimumab alone 24 weeks: $-0.4(0.5)$; $p = 0.690$</p>

continued

Study details and design	Participant details	Intervention/outcome/analyses details	Results
	<p><i>Psoriasis history</i></p> <p>Mean (SD) duration: Adalimumab: 17.2 years (12) Placebo: 17.1 years (12.6)</p> <p><i>Psoriasis evaluation</i></p> <p>Patients with > 3% BSA affected with psoriasis: Adalimumab: 70/151 (46.4%) Placebo: 70/162 (43.2%)</p> <p><i>Concurrent therapies</i></p> <p>MTX use was permitted if it had been taken for ≥3 months previously, with a stable dose for ≥4 weeks prior to the trial</p> <p><i>Concomitant therapy at baseline</i></p> <p>Concomitant MTX at baseline: Adalimumab 77/151 (51%) Placebo 81/162 (50%)</p>	<p><i>ITT analysis</i></p> <p>The analyses were performed on an ITT basis</p>	<p><i>12-week HAQ mean change conditional on PsARC response at 12 weeks</i></p> <p>PsARC responders: Adalimumab ($n=93$): -0.5 (0.4); placebo ($n=42$): -0.3 (0.5)</p> <p>PsARC non-responders: Adalimumab ($n=58$): -0.1 (0.4); placebo ($n=120$): -0.0 (0.4)</p> <p><i>24 week HAQ mean change conditional on PsARC response at 12 weeks</i></p> <p>PsARC responders: Adalimumab ($n=90$): -0.5 (0.49); placebo ($n=37$): -0.3 (0.49)</p> <p>PsARC non-responders: Adalimumab ($n=61$): -0.1 (0.39); placebo ($n=125$): -0.1 (0.39)</p> <p><i>Mean PASI at baseline (SD)</i></p> <p>Adalimumab: 7.4 (6.0); placebo: 8.3 (7.2)</p> <p><i>PASI 50</i></p> <p>Adalimumab 12 weeks: 72% (50/69); placebo 12 weeks: 15% (10/69); $p<0.001$</p> <p>Adalimumab 24 weeks: 75% (52/69); placebo 24 weeks: 12% (8/69); $p<0.001$</p> <p>Adalimumab + MTX 12 weeks: 76% (17/29); adalimumab alone 12 weeks: 70% (28/40); $p=0.785$</p> <p>Adalimumab + MTX 24 weeks: 86% (25/29); adalimumab alone 24 weeks: 68% (27/40); $p=0.094$</p> <p><i>PASI 75</i></p> <p>Adalimumab 12 weeks: 49% (34/69); placebo 12 weeks: 4% (3/69); $p<0.001$</p> <p>Adalimumab 24 weeks: 59% (41/69); placebo 24 weeks: 1% (1/69); $p<0.001$</p> <p>Adalimumab + MTX 12 weeks: 59% (17/29); adalimumab alone 12 weeks: 43% (17/40); $p=0.227$</p> <p>Adalimumab + MTX 24 weeks: 72% (21/29); adalimumab alone 24 weeks: 50% (20/40); $p=0.083$</p> <p><i>PASI 90</i></p> <p>Adalimumab 12 weeks: 30% (21/69); placebo 12 weeks: 0% (0/69); $p<0.001$</p> <p>Adalimumab 24 weeks: 42% (29/69); placebo 24 weeks: 0% (0/69); $p<0.001$</p> <p>Adalimumab + MTX 12 weeks: 38% (11/29); adalimumab alone 12 weeks: 25% (10/40); $p=0.295$</p> <p>Adalimumab + MTX 24 weeks: 52% (15/29); adalimumab alone 24 weeks: 35% (14/40); $p=0$</p> <p><i>Concurrent joint and skin response (PsARC and PASI 75)</i></p> <p>Adalimumab 12 weeks: 42% (29/69); placebo 12 weeks: 1% (1/69); $p<0.001$</p> <p>Adalimumab 24 weeks: 42% (29/69); placebo 24 weeks: 0% (0/69); $p<0.001$</p> <p><i>TSS change from baseline</i></p> <p>Adalimumab 24 weeks: -0.2 ($n=144$); placebo 24 weeks: 0.1 ($n=152$); $p<0.001$</p>

Study details and design	Participant details	Intervention/outcome/analyses details	Results
			<p><i>SF-36 mean change from baseline (SD)</i></p> <p>Physical component summary:</p> <p>Adalimumab baseline: 33.2 (9.9); placebo baseline: 33.3 (9.8); $p < 0.001$</p> <p>Change, adalimumab 12 weeks: 9.3 (10.0); placebo 12 weeks: 1.4 (8.7); $p < 0.001$</p> <p>Change, adalimumab 24 weeks: 9.3 (10.1); placebo 24 weeks: 1.4 (9.6); $p < 0.001$</p> <p>Mental component summary:</p> <p>Adalimumab baseline: 48.1 (10.2); placebo baseline: 46.6 (12.2); $p < 0.001$</p> <p>Change, adalimumab 12 weeks: 1.6 (10.1); placebo 12 weeks: 1.2 (10.2); $p = 0.71$</p> <p>Change, adalimumab 24 weeks: 1.8 (9.3); placebo 24 weeks: 0.6 (10.4); $p = 0.29$</p> <p>STAGE 1: ADVERSE EVENTS</p> <p><i>Infectious adverse events including any serious infections</i></p> <p>(Placebo, P; adalimumab, A)</p> <p>Upper respiratory tract infection: P, 24/162 (14.8%); A 19/151 (12.6%)</p> <p>Nasopharyngitis: P, 15/162 (9.3%); A 15/151 (9.9%)</p> <p>Diarrhoea: P, 9/162 (5.6%); A, 3/151 (2.0%)</p> <p><i>Infections that required hospitalisation or use of i.v. antibiotics</i></p> <p>Adalimumab: 1/151 (one – viral meningitis)</p> <p>Placebo: 2/162 (one – pericarditis, one – cellulitis)</p> <p><i>Malignancy: None</i></p> <p><i>Reactivation of latent TB: Not reported</i></p> <p><i>Deaths: None</i></p> <p><i>Withdrawals due to adverse events (no. of patients)</i></p> <p>Adalimumab: 3</p> <p>Placebo: 1</p> <p>STAGE 2: EFFICACY OUTCOMES (24–144 WEEKS)</p> <p><i>ACR 20</i></p> <p>Adalimumab 48 weeks: 58.7% (165/281)</p> <p>Adalimumab 104 weeks: 57.3% (161/281)</p> <p><i>ACR 50</i></p> <p>Adalimumab 48 weeks: 42.7% (120/281)</p> <p>Adalimumab 104 weeks: 45.2% (127/281)</p> <p><i>ACR 70</i></p> <p>Adalimumab 48 weeks: 27.8% (78/281)</p> <p>Adalimumab 104 weeks: 29.9% (84/281)</p> <p><i>HAQ mean change from baseline (SD)</i></p> <p>Adalimumab ($n=298$) 48 weeks: -0.3 (0.5)</p> <p>Adalimumab ($n=271$) 104 weeks: -0.3 (0.5)</p> <p><i>HAQ percentage change from baseline (SD)</i></p> <p>Adalimumab 48 weeks: -41.9% (114/271)</p> <p>Adalimumab 104 weeks: -42.7% (116/271)</p>

continued

Study details and design	Participant details	Intervention/outcome/analyses details	Results
			<p><i>Mean changes in modified TSS</i></p> <p>Adalimumab (<i>n</i> = 115) 48 weeks: 0.1 (1.95); adalimumab/placebo (<i>n</i> = 128) 48 weeks: 0.8 (4.23)</p> <p>Adalimumab (<i>n</i> = 115) 144 weeks: 0.5 (4.20); adalimumab/placebo (<i>n</i> = 128) 144 weeks: 0.9 (6.36)</p> <p><i>Percentage changes (increase) in modified TSS</i></p> <p>Adalimumab 48 weeks: 26.6% (34/115); adalimumab/placebo 48 weeks: 11.3% (13/128)</p> <p>Adalimumab 144 weeks: 20.9% (24/115); adalimumab/placebo 144 weeks: 31.3% (40/128)</p> <p><i>PASI 50</i></p> <p>Adalimumab 48 weeks: 67% (46/69); adalimumab/placebo 48 weeks: 61% (42/69)</p> <p><i>PASI 75</i></p> <p>Adalimumab 48 weeks: 58% (40/69); adalimumab/placebo 48 weeks: 53% (37/69)</p> <p><i>PASI 90</i></p> <p>Adalimumab 48 weeks: 46% (32/69); adalimumab/placebo 48 weeks: 44% (30/69)</p> <p><i>STAGE 2: ADVERSE EVENTS (24–144 WEEKS)</i></p> <p><i>Any serious adverse events</i></p> <p>Adalimumab exposure: 16.8% (50/298)</p> <p><i>Infections that required hospitalisation or use of i.v. antibiotics</i></p> <p>Adalimumab exposure: 5% (15/298)</p> <p><i>Cancer</i></p> <p>Any malignancies: 1.3% (4/298)</p> <p>Lymphoma: 0.3% (1/298)</p> <p>Non-melanoma skin cancers: 0.7% (2/298)</p> <p>Other malignancies: 0.3% (1/298)</p> <p><i>Reactivation of latent TB</i></p> <p>Adalimumab exposure: 0.3% (1/298)</p> <p><i>Deaths</i></p> <p>Adalimumab exposure: 1.0% (3/298)</p> <p><i>Withdrawals due to AEs (no. of patients)</i></p> <p>Adalimumab exposure: 6.7% (20/298)</p>

Study details and design	Participant details	Intervention/outcome/analyses details	Results
<p>Genovese, 2007, USA⁴³</p> <p><i>Type of publication:</i> Full publication</p> <p><i>Funding:</i> Abbott</p> <p><i>Study design</i></p> <p>Stage 1: Double-blind RCT</p> <p>Stage 2: Open-label extension</p> <p><i>Setting:</i> Outpatient</p> <p><i>Duration of follow-up</i></p> <p>Stage 1: 0–12 weeks</p> <p>Stage 2: 12–24 weeks</p> <p><i>Frequency of follow-up</i></p> <p>Baseline, 2, 4, 8, 12, 14, 18 and 24 weeks</p> <p><i>Extracted by:</i> HY</p> <p><i>Checked by:</i> MR</p>	<p><i>Inclusion/exclusion criteria</i></p> <p>Adults aged 18 years or above had generally good health based on medical history, physical examination, laboratory profile, chest radiograph, and 12-lead electrocardiogram. Patient must have three or more swollen and tender or painful joints, and either an active cutaneous lesion of chronic plaque psoriasis or a documented history of chronic plaque psoriasis. All patients received concomitant DMARD therapy or had a history of DMARD therapy with an inadequate response</p> <p>Patients were excluded if they had the following treatment: (1) previous biologic therapy; (2) i.v. infusion or intra-articular injections of corticosteroids within 4 weeks of baseline; (3) topical psoriasis therapies within 2 weeks of baseline; (4) UVA phototherapy or use of tanning booth within 2 weeks of baseline; (5) oral retinoids within 4 weeks of the baseline visit, alefacept or siplizumab within 12 weeks, or any other biologic or investigational therapy within 6 weeks of the baseline visit; and (6) antiretroviral therapy at any time</p> <p><i>No. randomised:</i> 102</p> <p><i>Mean age (SD)</i></p> <p>Adalimumab: 50.4 years (11.0);</p> <p>Placebo: 47.7 years (11.3)</p>	<p><i>Intervention: adalimumab criteria</i></p> <p>Dose regimen: 40 mg every other week</p> <p>Length of treatment: 12 weeks</p> <p>No. randomised: 51</p> <p>No. completed: 50</p> <p>Comparator: Placebo</p> <p>Dose regimen: Equivalent</p> <p>Length of treatment: 12 weeks</p> <p>No. randomised: 51</p> <p>No. completed: 46</p> <p><i>Primary outcome</i></p> <p>ACR 20% criteria for improvement in RA (ACR 20) at week 12</p> <p><i>Sample size calculation:</i></p> <p>Assuming that a response rate of 25% on placebo and 60% on adalimumab, the sample size of 50 patients per groups gave 90% power to detect a significant difference between treatments on the primary outcome, with $\alpha = 0.05$ (two-sided)</p> <p><i>Statistical analyses:</i></p> <p>Proportions of patients responding were compared using the Cochran–Mantel–Haenszel test, with baseline DMARD use as the stratification factor. ACR 20 at response rates at time points except for week 12, and ACR 50 and ACR 70 rates at all time points were analysed using Fisher’s exact test, combining baseline DMARD use categories. Continuous data were analysed using ANOVA with factors of baseline DMARD use and treatment. Non-responder imputation for missing data was used for analyses of ACR and PsARC responses, and LOCF was used for all other efficacy measures</p>	<p><i>STAGE 1: EFFICACY OUTCOMES</i></p> <p><i>ACR 20</i></p> <p>Adalimumab 12 weeks: 39% (20/51); placebo 12 weeks: 16% (8/49); $p < 0.05$</p> <p><i>ACR 50</i></p> <p>Adalimumab 12 weeks: 25% (13/51); placebo 12 weeks: 2% (1/49); $p < 0.001$</p> <p><i>ACR 70</i></p> <p>Adalimumab 12 weeks: 14% (7/51); placebo 12 weeks: 0% (0/49); $p < 0.05$</p> <p><i>PsARC</i></p> <p>Adalimumab 12 weeks: 51% (26/51); placebo 12 weeks: 24% (12/49); $p = 0.007$</p> <p><i>Mean HAQ at baseline (SD)</i></p> <p>Adalimumab: 0.9(0.5); placebo: 1.0(0.7)</p> <p><i>HAQ mean change from baseline (SD)</i></p> <p>Adalimumab 12 weeks: $-0.3(0.5)$; placebo 12 weeks: $-0.1(0.3)$; $p < 0.01$</p> <p><i>12-week HAQ mean change conditional on PsARC response at 12 weeks</i></p> <p>PsARC responders:</p> <p>Adalimumab ($n = 26$): $-0.4(0.4)$; placebo ($n = 12$): $-0.2(0.3)$</p> <p>PsARC non-responders:</p> <p>Adalimumab ($n = 26$): $-0.1(0.4)$; placebo ($n = 12$): $-0.1(0.3)$</p> <p><i>Patient global assessment of disease activity (improvement from baseline)</i></p> <p>Adalimumab 12 weeks: $-14.8(24.5)$; placebo 12 weeks: $-0.4(24.9)$; $p < 0.004$</p> <p><i>Physician global assessment of disease activity (improvement from baseline)</i></p> <p>Adalimumab 12 weeks: $-21.4(22.4)$; placebo 12 weeks: $-9.7(18.2)$; $p < 0.005$</p> <p><i>Physician global assessment for psoriasis ('clear' or 'minimal')</i></p> <p>Adalimumab 12 weeks: 40.6% (13/32); placebo 12 weeks: 6.7% (2/30); $p < 0.002$</p> <p><i>Target lesion score mean change from baseline (SD)</i></p> <p>Adalimumab 12 weeks: $-3.7(3.3)$; placebo 12 weeks: $-0.3(3.1)$; $p < 0.001$</p> <p><i>Mean (SD) SF-36 at baseline</i></p> <p>Physical component summary:</p> <p>Adalimumab: 34.9 (9.2); placebo: 32.7 (11.3)</p> <p>Mental component summary:</p> <p>Adalimumab: 48.1 (10.2); placebo: 46.6 (10.2)</p> <p><i>SF-36 mean change from baseline (SD)</i></p> <p>Physical component summary:</p> <p>Adalimumab 12 weeks: 5.7 (8.5); placebo 12 weeks: 2.8 (7.1); $p = 0.08$.</p>

continued

Study details and design	Participant details	Intervention/outcome/analyses details	Results
	<p><i>Gender</i></p> <p>Adalimumab: Male 29/51 (56.9%)</p> <p>Placebo: Male 25/49 (51%)</p> <p><i>PsA history</i></p> <p>Mean (SD) duration:</p> <p>Adalimumab: 7.5 years (7.0)</p> <p>Placebo: 7.2 years (7.0)</p> <p><i>Psoriasis history</i></p> <p>Mean (SD) duration:</p> <p>Adalimumab: 18.0 years (13.2)</p> <p>Placebo: 13.8 years (10.7)</p> <p><i>Psoriasis evaluation</i></p> <p>(CiC information has been removed)</p> <p><i>Concurrent therapies:</i> All patients were permitted to use concomitant DMARD therapy or had a history of DMARD therapy with an inadequate response. Oral corticosteroids were permitted to use if the dosage did not exceed the equivalent of prednisone 10 mg/day and had been stable during the 4 weeks prior to the trial. Concomitant treatments with MTX or other DMARD, with the exception of ciclosporin and tacrolimus received within 4 weeks of the baseline visit, were permitted if the patient had received a minimum of 3 months of therapy and the dosage was stable during the 4 weeks prior to the trial. The maximum allowable MTX dosage was 30 mg/week</p>	<p><i>ITT analysis</i></p> <p>The analyses were performed on an ITT basis</p>	<p>Mental component summary:</p> <p>Adalimumab 12 weeks: 1.1 (7.4); placebo 12 weeks: -0.6 (7.8); $p=0.24$</p> <p><i>DLQI mean change from baseline (SD)</i></p> <p>Adalimumab 12 weeks: -3.4 (4.5); placebo 12 weeks: -1.7 (5.3); $p=0.171$</p> <p><i>STAGE 1: ADVERSE EVENTS</i></p> <p>Infectious adverse events including any serious infections (Placebo, P; adalimumab, A)</p> <p>Any infectious adverse events: P, 16/49 (32.7%); A, 9/51 (17.6%)</p> <p>Upper respiratory tract infection: P, 4/49 (8.2%); A, 7/51 (13.7%)</p> <p>Diarrhoea: P, 3/49 (6.1%); A, 1/51 (2.0%)</p> <p><i>Infections that required hospitalisation or use of i.v. antibiotics</i></p> <p>Adalimumab: 1/51</p> <p>Placebo: 1/49</p> <p><i>Non-infectious serious adverse events</i></p> <p>Adalimumab: 1/51 (diverticulitis)</p> <p>Placebo: 2/49 (one sublingual abscess, one benign paraganglioma neoplasm)</p> <p><i>Cancer:</i> None</p> <p><i>Reactivation of latent TB:</i> None</p> <p><i>Deaths:</i> None</p> <p><i>Withdrawals due to adverse events (no. of patients)</i></p> <p>Adalimumab: 1</p> <p>Placebo: 2</p> <p><i>STAGE 2: EFFICACY OUTCOMES</i></p> <p><i>ACR 20</i></p> <p>Adalimumab 24 weeks: 65% (33/51); adalimumab/placebo 24 weeks: 57% (26/46)</p> <p><i>ACR 50</i></p> <p>Adalimumab 24 weeks: 43% (22/51); adalimumab/placebo 24 weeks: 37% (17/46)</p> <p><i>ACR 70</i></p> <p>Adalimumab 24 weeks: 27% (13/51); adalimumab/placebo 24 weeks: 22% (10/46)</p> <p><i>PsARC</i></p> <p>Adalimumab 24 weeks: 75% (38/51); adalimumab/placebo 24 weeks: 70% (32/46)</p> <p><i>HAQ mean change from baseline (SD)</i></p> <p>Adalimumab 24 weeks: -0.3(0.5); adalimumab/placebo 24 weeks: -0.4(0.4)</p> <p><i>Physician global assessment for psoriasis ('clear' or 'minimal')</i></p> <p>Adalimumab 24 weeks: 56.3% (18/32); adalimumab/placebo 24 weeks: 50% (13/26)</p>

Study details and design	Participant details	Intervention/outcome/analyses details	Results
	<p><i>Concomitant therapy at baseline</i></p> <p>Concomitant MTX at baseline:</p> <p>Adalimumab 24/51 (47.1%)</p> <p>Placebo 23/49 (46.9%)</p>		<p><i>SF-36 mean change from baseline (SD)</i></p> <p>Physical component summary:</p> <p>Adalimumab 24 weeks: 8.6 (7.4); adalimumab/placebo 24 weeks: 11.7(9.1)</p> <p>Mental component summary:</p> <p>Adalimumab 24 weeks: 1.9 (8.2); adalimumab/placebo 24 weeks: 0.3 (9.7)</p> <p><i>DLQI mean change from baseline (SD)</i></p> <p>Adalimumab 24 weeks: -3.5 (5.1); adalimumab/placebo 24 weeks: -3.9 (6.4)</p> <p><i>STAGE 2: ADVERSE EVENTS (WEEKS 12-24)</i></p> <p><i>Infectious adverse events including any serious infections (Adalimumab/placebo)</i></p> <p>Any infectious adverse events: 29/97 (29.9%)</p> <p>Upper respiratory tract infection: 6/97 (6.2%)</p> <p>Diarrhoea: 2/97 (2.1%)</p> <p><i>Infections that required hospitalisation or use of i.v. antibiotics</i></p> <p>Adalimumab/placebo: 0% (0/97)</p> <p><i>Malignancy:</i> Three cases (one non-Hodgkin's lymphoma, one squamous cell carcinoma of the skin and one adenocarcinoma of the prostate)</p> <p><i>Reactivation of latent TB:</i> None</p> <p><i>Deaths:</i> None</p> <p><i>Withdrawals due to adverse events (no. of patients):</i> Not reported</p>

ANOVA, analysis of variance.

Adverse events data extraction

Study details and design	Intervention and duration of follow-up	No. of patients receiving biologics	No. of patients with any infection	Infections that required hospitalisation or use of i.v. antibiotics (no. of patients)	Malignancy (no. of patients)	TB (no. of patients)	Deaths (no. of patients)	Withdrawals due to adverse events (no. of patients)
Multiple biologics								
Brassard 2006 ³⁵	Etanercept and infliximab	Etanercept: 2349 patients with RA	NR	NR	NR	Etanercept: 32 (1.4%) Infliximab: 19 (1.8%)	NR	NR
Weeks control study	373.9 days (mean)	Infliximab: 1074 patients with RA						
Carmona 2005 ⁴¹	Etanercept, infliximab and adalimumab	Total: 4092 patients of RA, AS, PSA, juvenile idiopathic arthritis and other chronic inflammatory rheumatic conditions	NR	NR	NR	Infliximab: 34 (4.6%), of whom 28 had RA Etanercept: None (0%) Adalimumab: None (0%)	One patient with TB died of liver failure	NR
Multicenter surveillance study	5 years	It includes 2833 (69%) patients with RA						
Curtis 2007 ¹³⁴	Etanercept, infliximab and adalimumab	Etanercept: 2227 Infliximab: 739 Adalimumab: 154	NR	65 (2.7%)	NR	NR	NR	NR
Retrospective cohort study	20 months (mean)	Etanercept: 1201 Infliximab: 792 Adalimumab: 118						
	More than one biologic: 282	Total: 2393 patients with RA						
Dixon 2006 ¹³⁶	Etanercept, infliximab and adalimumab	Etanercept: 3596 Infliximab: 2878 Adalimumab: 1190	NR	Etanercept: 209 (5.8%) Infliximab: 255 (8.9%) Adalimumab: 61 (5.1%)	NR	Etanercept: 2 (0.06%) Infliximab: 7 (0.2%) Adalimumab: 1 (0.08%)	NR	NR
Prospective cohort study	1.26 years (median)	Total: 7664 patients with RA						

Study details and design	Intervention and duration of follow-up	No. of patients receiving biologics	No. of patients with any infection	Infections that required hospitalisation or use of i.v. antibiotics (no. of patients)	Malignancy (no. of patients)	TB (no. of patients)	Deaths (no. of patients)	Withdrawals due to adverse events (no. of patients)
Dixon 2007 ¹⁴⁷ Prospective cohort study	Etanercept, infliximab and adalimumab 24 months	Etanercept: 3844 Infliximab: 2944 Adalimumab: 1871 Total: 8659 patients with RA	NR	Etanercept: 432 (11.2%) Infliximab: 405 (13.8%) Adalimumab: 138 (7.3%)	NR	NR	NR	NR
Dreyer 2009 ¹⁴⁸ Prospective cohort study	Etanercept, infliximab and adalimumab 6092 patient-years	Total: 3688	NR	NR	NR	30 cancers in 28 patients (0.76%)	NR	NR
Favalli 2009 ²⁹ Cohort study	Etanercept, infliximab and adalimumab 24.21 months	Etanercept: 242 Infliximab: 519 Adalimumab: 303 Total: 1064 patients with RA	NR	Etanercept: 11 (4.5%) Infliximab: 42 (8.1%) Adalimumab: 20 (6.6%)	NR	Etanercept: 1 (0.4%) Infliximab: 3 (0.6%) Adalimumab: 1 (0.3%)	Total (all serious infection): 4 (0.4%)	NR
Gomez-Reino 2003 ¹⁴⁶ Multicenter surveillance study	Etanercept Infliximab 1.1 years (mean)	1540 patients of RA, PsA and AS	118 (7.6%)	10 sepsis (0.65%)	NR	Etanercept: 0 (0%) Infliximab: 17 (1.1%)	Serious infection: 2 (0.1%)	NR
Gomez-Reino 2007 ¹³² Multicenter surveillance study ¹³²	Etanercept, infliximab and adalimumab NR	Etanercept: 1336 Infliximab: 1137 Adalimumab: 615 Total: 3088 patients with rheumatic diseases	NR	NR	NR	Etanercept: 2 (0.1%) Infliximab: 5 (0.4%) Adalimumab: 1 (0.2%)	NR	NR
Listing 2005 ²² Prospective cohort study	Etanercept and infliximab 12 months	Etanercept: 512 patients with RA Infliximab: 346 patients with RA	Etanercept: 109 (21.3%) Infliximab: 92 (26.6%)	Etanercept: 31 (6.1%) Infliximab: 20 (5.8%)	NR	Etanercept: 0 (0%) Infliximab: 1 (0.3%)	Serious infection: 4 (0.5%)	NR

continued

Study details and design	Intervention and duration of follow-up	No. of patients receiving biologics	No. of patients with any infection	Infections that required hospitalisation or use of i.v. antibiotics (no. of patients)	Malignancy (no. of patients)	TB (no. of patients)	Deaths (no. of patients)	Withdrawals due to adverse events (no. of patients)
Etanercept								
Fleischmann 2006 ⁸⁹ Integrated data of trials	Etanercept NR	Etanercept: 3132 patients with RA, PsA and AS Control: 1190 patients receiving placebo or MTX	Etanercept: 1704 (54.4%) Control (placebo or MTX): 493 (41.4%)	Etanercept: 155 (4.9%) Control (placebo or MTX): 25 (2.1%)	NR	None	Etanercept and control: 41 (0.9%)	Etanercept: 204 (6.5%) Control (placebo or MTX): 57 (4.8%)
Horneff 2009 ²⁵ Open, non-randomised study	Etanercept 12 months	604 patients of juvenile idiopathic arthritis	58 (9.6%)	26 (4.3%)	NR	NR	None (0%)	NR
Klareskog 2006 ²⁰ Open-label extension	Etanercept 5 years	549 patients with RA	146 (26.5%)	89 (16.2%)	Total: 7 (1.3%) Lung cancer: 2 (0.4%) Breast cancer: 3 (0.5%) Lymphoma: 1 (0.2%) Basocellular skin cancer: 2 (0.4%)	None	Total: 10 (1.8%) Serious infection: 7 (1.3%)	25 (4.6%)
Mease 2006 ⁸⁷ Open-label extension	Etanercept 48 weeks	169 patients with PsA	3 (1.8%)	1 (0.6%)	NR	NR	None (0%)	None (0%)
Moreland 2006 ²¹ Data from RCTs or open-label extension	Etanercept 7 years	714 patients with RA	NR	94 (13.2%)	Total: 41 (5.7%) Squamous cell carcinoma of larynx: 1 Lymphoma: 7 Lung cancer: 5 Ovarian cancer: 4 Breast cancer: 3 Leukaemia: 2 Prostate cancer: 2 Malignant melanoma: 2 Squamous cell skin carcinomas: 4 Basal cell skin carcinomas: 11	None	Total: 22 (3.1%) Serious infection: 2 Malignancy: 3	97 (13.6%; due to adverse events and deaths)

Study details and design	Intervention and duration of follow-up	No. of patients receiving biologics	No. of patients with any infection	Infections that required hospitalisation or use of i.v. antibiotics (no. of patients)	Malignancy (no. of patients)	TB (no. of patients)	Deaths (no. of patients)	Withdrawals due to adverse events (no. of patients)
Feltelius 2005 ⁴² Nationwide postmarketing cohort study	Etanercept 24 months	1073 patients with RA	120 (11%)	Total: 28 (2.6%) Sepsis: 8 Pneumonia: 8 Osteitis: 3 Infectious arthritis: 2 Soft tissue abscess: 2 Gastroenteritis: 2 Recurrent fever: 1 Skin inflammation: 1 Encephalitis: 1	Total: 11 (1%) Lymphoma: 3 Benign respiratory tract neoplasm: 2 Unspecified liver cancer: 1 Primary liver cancer: 1 Benign gastrointestinal neoplasm: 1 Ovarian cancer: 1 Cervical cancer: 1 Rectal cancer: 1	NR	Total: 3 (0.3%) Serious infection: 1 Malignancy: 1	59 (5.5%)
Infliximab								
Antoni 2008 ⁸⁹ Open-label extension	Infliximab 98 weeks	78 patients with PsA	URT: 30 (38.5%) Diarrhoea: 7 (9.0%) Pharyngitis: 7 (9.0%) Sinusitis: 4 (5.1%) Urinary tract infection: 4 (5.1%)	2 (2.6%: one knee wound, one bowel)	Total: Four neoplasms (5.1%) Benign abdominal mucinous systoma: 1 Non-resectable pancreatic ductal adenocarcinoma: 1 Mild haemangioma: 1 Leucocytthaemia: 1	None (0%)	NR	5 (6.4%)
Caspersen 2008 ²⁸ Cohort study	Infliximab 6 years	651 patients with Crohn's disease	NR	Total: 66 (10.1%) Abscesses: 34 Pneumonia: 16 Sepsis: 8 Pleuritis: 2 <i>Aspergillus pneumonia</i> : 2 Keratoconjunctivitis: 2 Bone infection in jaw: 1 Exacerbation of osteomyelitis: 1	Total: 4 (0.6%) Relapse of breast cancer: 1	2 (0.3%)	Total: 13 (2.0%) Serious infection: 4 Malignancy: 1	NR

continued

Study details and design	Intervention and duration of follow-up	No. of patients receiving biologics	No. of patients with any infection	Infections that required hospitalisation or use of i.v. antibiotics (no. of patients)	Malignancy (no. of patients)	TB (no. of patients)	Deaths (no. of patients)	Withdrawals due to adverse events (no. of patients)
Colombel 2004 ¹²⁴ Retrospective cohort study	Infliximab 17 months (median)	500 patients with Crohn's disease	48 (9.6%)	Total: 15 (3.0%) Sepsis: 2 Pneumonia: 8 Histoplasmosis: 1 Viral infections: 1 Abscesses: 2 Cutaneous infections: 1	Total: 9 (1.8%) Cancer: 7 (two lung cancer, one abdominal carcinomatosis, two squamous cell carcinoma, two basal cell carcinoma) Non-Hodgkin's lymphoma: 1 Hodgkin's lymphoma: 1	NR	Total: 10 (2%) Serious infection: 4 Malignancy: 2	NR
Fidler 2009 ¹¹⁹ Retrospective cohort study	Infliximab 58 months (median)	734 patients with IBD	NR	48 (6.5%)	21 (2.9%)	1 (0.1%)	Total: 12 (1.6%) Serious infection: 1 Malignancy: 3	NR
Oka 2006 ¹³⁷ Postmarketing surveillance data	Infliximab 22 weeks	5000 patients with RA	NR	Lung infections: 155 (3.1%)	NR	14 (0.3%)	Total: 3 (0.06%) Serious infection: 3	NR
Schnitzler 2009 ²⁷ Retrospective cohort study	Infliximab 55 months (median)	614 Crohn's disease patients	NR	5 serious infections (0.8%); 1 fatal <i>Aspergillus</i> , 1 abdominal TB	1 pancreatic carcinoma (0.16%)	NR	Total: 10 (1.6%) 1 fatal <i>Aspergillus</i> infection	70 (12.8%)
St. Clair 2004 ¹⁴³ RCT	Infliximab + MTX ~54 weeks	749 early patients with RA	URT: 200 (26.7%) Sinusitis: 73 (9.7%) Pharyngitis: 103 (13.8%)	At least 1 serious infection: 40 (5.3%) Pneumonia: 15 (2.0%) TB: 4 (0.5%) Sepsis: 3 (0.4%) Bronchitis: 2 (0.27%) Septic bursitis: 2 (0.27%)	Total: 4 (0.5%) 1 endometrial cancer 1 pancreatic cancer 1 colon adenocarcinoma 1 acute myeloid leukaemia	4 (0.5%)	Total: 2 (0.27%) 1 pancreatic cancer	69/722 (9.6%)

Study details and design	Intervention and duration of follow-up	No. of patients receiving biologics	No. of patients with any infection	Infections that required hospitalisation or use of i.v. antibiotics (no. of patients)	Malignancy (no. of patients)	TB (no. of patients)	Deaths (no. of patients)	Withdrawals due to adverse events (no. of patients)
Takeuchi 2008 ³⁰ Prospective cohort study	Infliximab 6 months	5000 patients with RA	Total: 433 (8.7%)	Bacterial pneumonia: 108 (2.2%) (Suspected <i>Pneumocystis jirovecii</i> pneumonia: 22 (0.4%) Interstitial pneumonitis: 25 (0.5%)	All neoplasms: 8 (0.16%)	14 (0.3%)	NR	NR
Westhovens 2006 ³⁹ RCT	Infliximab + MTX 22 weeks 54 weeks	721 patients with RA at 22 weeks 1001 patients with RA at 54 weeks	0–22 weeks URT: 78 (10.8%) Pharyngitis: 34 (4.7%) Sinusitis: 30 (4.2%) Pneumonia: 6 (0.8%) TB: 3 (0.4%) Cellulitis: 2 (0.3%) UTI: 2 (0.3%) 22–54 weeks Total: 354 (35.4%)	0–22 weeks Pneumonia: 6 (0.8%) TB: 3 (0.4%) Cellulitis: 2 (0.3%) UTI: 2 (0.3%) 22–54 weeks Total: 26 (2.6%) Details reported	0–22 weeks 3 (0.4%)	Total: 4 (0.4%) 1 TB	0–22 weeks 38/721 (5.3%)	
Wolfe 2004 ¹⁴⁴ Prospective cohort study	Infliximab 2.5 years	6460 patients with RA	NR	22–54 weeks Total: 31 (3.1%) Pneumonia: 12 (1.2%) TB: 4 (0.4%) Abscess: 6 (0.6%) Pyelonephritis: 3 (0.3%)	NR	4 (0.06%)	NR	22–54 weeks 87/1084 (8.0%)

continued

Study details and design	Intervention and duration of follow-up	No. of patients receiving biologics	No. of patients with any infection	Infections that required hospitalisation or use of i.v. antibiotics (no. of patients)	Malignancy (no. of patients)	TB (no. of patients)	Deaths (no. of patients)	Withdrawals due to adverse events (no. of patients)
Adalimumab								
Breedveld 2006 ⁴⁰ RCT	Adalimumab ±MTX 2 years	542 patients with RA	Total: 9.12% (estimated)	Total: 12 (2.2%) Pulmonary infection: 4 (0.74%) Sinus infection: 1 (0.18%) Wound infection: 1 (0.18%) Septic arthritis: 2 (0.37%) Infected hygroma: 1 (0.18%) Cellulitis: 2 (0.37%) UTI: 1 (0.18%)	Total: 6 (1.1%)	1 (0.18%)	Total: 5 (0.9%) Cancer: 3 (0.55%)	58/542 (10.7%)
Burmester 2007 ³¹ Uncontrolled open-label study	Adalimumab ±DMARD Median: 211 days	6610 patients with RA	NR	202 (3.1%)	43 (0.7%)	21 (0.3%)	Total: 35 (0.5%) TB: 1	682/6610 (10.3%)
Colombel 2007 ³³ RCT	Adalimumab 56 weeks	CD patients: 0–4 weeks, <i>n</i> = 854; 4–56 weeks, <i>n</i> = 517	0–4 weeks 130 (15.2%)	0–4 weeks 10 (1.2%)				0–4 weeks 54/854 (6.3%)
Rudwaleit 2009 ²⁶ Uncontrolled open-label study	Adalimumab Median: 12 weeks	969 AS patients with advanced spinal fusion	4–56 weeks 234 (45.3%)	4–56 weeks 14 (2.7%) 4 (0.4%)	4–56 weeks 1 breast cancer (0.2%) NR	4–56 weeks 2 (0.4%) NR	4–56 weeks 1 (0.2%) NR	4–56 weeks 30/517 (5.8%) NR
Schiff 2006 ³⁸ Analysis of clinical trial safety database	Adalimumab NR	10,050 patients with RA	NR	638 (6.3%)	15 lymphomas (0.1%)	34 (0.3%)	NR	NR

AS, ankylosing spondylitis; CD, Crohn's disease; IBD, inflammatory bowel disease; UTI, urinary tract infection.

Appendix 4

Table of excluded studies with rationale

Studies excluded from efficacy search

Study	Reason for exclusion ^a
Anandarajah AP, Ritchlin CT. Etanercept in psoriatic arthritis. <i>Expert Opin Biol Ther</i> 2003; 3 (1):169–77.	2
Antoni CE. Sustained benefits of infliximab therapy for dermatologic and articular manifestations of psoriatic arthritis: results from the infliximab multinational psoriatic arthritis controlled trial (IMPACT) (errata). <i>Arthritis Rheum</i> 2005; 52 (9):2951.	2
Batho J, Fleischmann R, Peloso P, Chon Y, Hooper M, Lin SL. Rates of cardiovascular events in patients with rheumatoid arthritis, psoriatic arthritis, and ankylosing spondylitis treated with etanercept or placebo in clinical trials. <i>Arthritis Rheum</i> 2006; 54 (Suppl. 9):188.	2
Bongiorno MR, Pistone G, Doukaki S, Arico M. Adalimumab for treatment of moderate to severe psoriasis and psoriatic arthritis. <i>Dermatol Ther</i> 2008; 21 (Suppl. 2):15–20.	2
Brodzky V, Pentek M, Gulacsi L. Efficacy of adalimumab, etanercept, and infliximab in psoriatic arthritis based on ACR 50 response after 24 weeks of treatment. <i>Scand J Rheumatol</i> 2008; 37 (5):399–400.	2
Colombel JF. Efficacy and safety of adalimumab for the treatment of Crohn's disease in adults. <i>Expert Rev Gastroenterol Hepatol</i> 2008; 2 (2):163–76.	2
Cruyssen BV, De Keyser F, Kruithof E, Mielants H, Van den Bosch F. Comparison of different outcome measures for psoriatic arthritis in patients treated with infliximab or placebo. <i>Ann Rheum Dis</i> 2006; 65 (Suppl. 2):546–7.	2
Frankel EH, Strober BE, Crowley JJ, Fivenson DP, Woolley JM, Yu EB, <i>et al.</i> Etanercept improves psoriatic arthritis patient-reported outcomes: results from EDUCATE. <i>Cutis</i> 2007; 79 (4):322–6.	2
Gottlieb AB, Kircik L, Eisen D, Jackson JM, Boh EE, Strober BE, <i>et al.</i> Use of etanercept for psoriatic arthritis in the dermatology clinic: the Experience Diagnosing, Understanding Care, and Treatment with Etanercept (EDUCATE) study. <i>J Dermatolog Treat</i> 2006; 17 (6):343–52.	2
Hamza S, Chon Y, Hooper M, MacPeck D, Lin S. Rates of serious infectious events and opportunistic infections in patients with rheumatoid arthritis, psoriatic arthritis, and ankylosing spondylitis treated with etanercept or placebo in clinical trials. <i>Ann Rheum Dis</i> 2007; 66 (Suppl. 2):171–2.	2
Kimball AB, Jackson JM, Sobell JM, Boh EE, Grekin S, Pharmed EBY, <i>et al.</i> Reductions in healthcare resource utilization in psoriatic arthritis patients receiving etanercept therapy: results from the educate trial. <i>J Drugs Dermatol</i> 2007; 6 (3):299–306.	2
Kristensen LE, Gulfe A, Saxne T, Geborek P. Efficacy and tolerability of anti-tumour necrosis factor therapy in psoriatic arthritis patients: results from the South Swedish Arthritis Treatment Group register. <i>Ann Rheum Dis</i> 2008; 67 (3):364–9.	2
Kvien TK, Heiberg MS, Lie E, Kaufmann C, Mikkelsen K, Nordvag BY, <i>et al.</i> A Norwegian DMARD register: prescriptions of DMARDs and biological agents to patients with inflammatory rheumatic diseases. <i>Clin Exp Rheumatol</i> 2005; 23 (Suppl. 39):188–94.	2
McHugh N, van den Bosch F, Manger B, Goupille P, Cooper R, Kron M, <i>et al.</i> Adalimumab treatment is effective in patients with psoriatic arthritis (PSA) in day-to-day clinical practice: results from the stereo trial. <i>Rheumatology</i> 2008; 47 (Suppl. 2):ii, 76.	2
Mease P. Infliximab (Remicade) in the treatment of psoriatic arthritis. <i>Ther Clin Risk Manag</i> 2006; 2 (4):389–400.	2
Mease PJ, Choy EHS, Atkins CJ, Sasso EH. Effectiveness of adalimumab in psoriatic arthritis patients with oligoarticular arthritis: subanalysis of ADEPT. Fourth European Academy of Dermatology and Venereology (EADV) Spring Symposium Saariselka, Lapland, Finland, 9–12 February, 2006: P-022.	5
Ravindran V, Scott DL, Choy EH. A systematic review and meta-analysis of efficacy and toxicity of disease modifying anti-rheumatic drugs and biological agents for psoriatic arthritis. <i>Ann Rheum Dis</i> 2008; 67 (6):855–9.	2
Revicki D, Willian MK, Saurat JH, Papp KA, Ortonne JP, Sexton C, <i>et al.</i> Impact of adalimumab treatment on health-related quality of life and other patient-reported outcomes: results from a 16-week randomized controlled trial in patients with moderate to severe plaque psoriasis. <i>Br J Dermatol</i> 2008; 158 (3):549–57.	3
Rinaldi F, Provenzano G, Termini A, Spinello M, La Seta F. Long term infliximab treatment for severe psoriatic arthritis: evidence of sustained clinical and radiographic response. <i>Ann Rheum Dis</i> 2005; 64 (9):1375–6.	2
Ritchlin C. Efficacy and safety of infliximab for the treatment of psoriatic arthritis. <i>Nat Clin Pract Rheumatol</i> 2006; 2 (6):300–1.	2

continued

Study	Reason for exclusion ^a
Romero-Mate A, Garcia-Donoso C, Cordoba-Guijarro S. Efficacy and safety of etanercept in psoriasis/psoriatic arthritis: an updated review. <i>Am J Clin Dermatol</i> 2007; 8 (3):143–55.	2
Saad AA, Symmons DPM, Noyce PR, Ashcroft DM. Risks and benefits of tumor necrosis factor-alpha inhibitors in the management of psoriatic arthritis: systematic review and metaanalysis of randomized controlled trials. <i>J Rheumatol</i> 2008; 35 (5):883–90.	2
Scheinfeld N. Adalimumab: a review of side effects. <i>Expert Opin Drug Saf</i> 2005; 4 (4):637–41.	2
Simpson D, Scott LJ. Adalimumab: in psoriatic arthritis. <i>Drugs</i> 2006; 66 (11):1487–96.	2
Spadaro A, Ceccarelli F, Scivo R, Valesini G. Life-table analysis of etanercept with or without methotrexate in patients with psoriatic arthritis. <i>Ann Rheum Dis</i> 2008; 67 (11):1650–1.	2
Strober B, Teller C, Yamauchi P, Miller JL, Hooper M, Yang YC, et al. Effects of etanercept on C-reactive protein levels in psoriasis and psoriatic arthritis. <i>Br J Dermatol</i> 2008; 159 (2):322–30.	4
Toussiro E, Streit G, Wendling D. Infectious complications with anti-TNFalpha therapy in rheumatic diseases: a review. <i>Recent Pat Inflamm Allergy Drug Discov</i> 2007; 1 (1):39–47.	2
Van den Bosch F, Reece R, Manger B, Goupille P, Roedevand E, Holck P, et al. Adalimumab (HUMIRA (R)) is effective and safe in treating psoriatic arthritis (PsA) in real-life clinical practice: preliminary results of the STEREO trial. <i>Arthritis Rheum</i> 2006; 54 (Suppl. 9):S719–20.	2
Van den Bosch F, McHugh NJ, Reece R, Cooper R, Manger B, Goupille P, et al. Treatment with adalimumab (Humira (R)) is safe and effective in psoriatic arthritis (PsA) patients in real-life clinical practice: preliminary results of the stereo trial. <i>Rheumatology</i> 2007; 46 (Suppl. 1):i,52–3.	2
Van den Bosch F, Manger B, Goupille P, McHugh N, Roedevand E, Holck P, et al. Adalimumab (Humira (R)) is effective in treating patients with psoriatic arthritis (PSA) in real-life clinical practice: results of the STEREO trial [abstract OP0147]. <i>Ann Rheum Dis</i> 2007; 66 (Suppl. 2):98.	2
Van den Bosch F, Manger B, Goupille P, Kron M, Kary S, Kupper H. Clinical remission and good clinical responses in patients with psoriatic arthritis (PsA) treated with adalimumab (HUMIRA (R)): results of the STEREO trial. <i>Arthritis Rheum</i> 2008; 58 (Suppl. 9):576.	2
Van Kuijk AWR, Gerlag DM, Vos K, Wolbink G, Zwinderman AH, Dijkmans BAC, et al. A randomized, placebo-controlled study to identify biomarkers associated with active treatment in psoriatic arthritis: effects of adalimumab treatment on synovial biomarkers. <i>Arthritis Rheum</i> 2008; 58 (Suppl. 9):415.	4
Winterfield LS, Menter A. Infliximab. <i>Dermatol Ther</i> 2004; 17 (5):409–26.	2
Winthrop KL, Siegel JN, Jereb J, Taylor Z, Lademarco MF. Tuberculosis associated with therapy against tumor necrosis factor alpha. <i>Arthritis Rheum</i> 2005; 52 (10):2968–74.	2

a Reasons for exclusion: 1, not relevant drug; 2, not RCT or extension; 3, not PsA; 4, no eligible outcomes; 5, unable to order.

Studies excluded from adverse event searches

Study	Reason for exclusion ^a
Anandarajah AP, Ritchlin CT. Etanercept in psoriatic arthritis. <i>Expert Opin Biol Ther</i> 2003; 3 (1):169–77.	2
Author not found. [Active tuberculosis after use of infliximab (Remicade).] <i>Geneesmiddelenbulletin</i> 2001; 35 (3):33.	2
Author not found. Infection risk with infliximab. <i>Pharm J</i> 2001; 266 (7129):7.	2
Baldin B, Dozol A, Spreux A, Chichmanian RM. [Tuberculosis and infliximab treatment: national surveillance from January 1, 2000, through June 30, 2003.] <i>Presse Med</i> 2005; 34 (5):353–7.	2
Boehncke WH, Prinz J, Gottlieb AB. Biologic therapies for psoriasis. A systematic review. <i>J Rheumatol</i> 2006; 33 (7):1447–51.	4
Brimhall AK, King LN, Licciardone JC, Jacobe H, Menter A. Safety and efficacy of alefacept, efalizumab, etanercept and infliximab in treating moderate to severe plaque psoriasis: a meta-analysis of randomized controlled trials. <i>Br J Dermatol</i> 2008; 159 (2):274–85.	4
Brown SL, Greene MH, Gershon SK, Edwards ET, Braun MM. Tumor necrosis factor antagonist therapy and lymphoma development: twenty-six cases reported to the Food and Drug Administration. <i>Arthritis Rheum</i> 2002; 46 (12):3151–8.	2
Caviglia R, Boskoski I, CiCala M. Long-term treatment with infliximab in inflammatory bowel disease: safety and tolerability issues. <i>Expert Opin Drug Saf</i> 2008; 7 (5):617–32.	4
Colombel JF. The CHARM trial of adalimumab in Crohn's disease. <i>Gastroenterol Hepatol (N Y)</i> 2006; 2 (7):486–8.	4
Colombel JF. Efficacy and safety of adalimumab for the treatment of Crohn's disease in adults. <i>Expert Rev Gastroenterol Hepatol</i> 2008; 2 (2):163–76.	4
Drosou A, Kirsner RS, Welsh E, Sullivan TP, Kerdel FA. Use of infliximab, an anti-tumor necrosis alpha antibody, for inflammatory dermatoses. <i>J Cutan Med Surg</i> 2003; 7 (5):382–6.	2

Study	Reason for exclusion ^a
Dunlop H. Infliximab (Remicade) and etanercept (Enbrel): serious infections and tuberculosis. <i>Can Med Assoc J</i> 2004; 171 (8):992–3.	1
Emery P, Breedveld FC, Hall S, Durez P, Chang DJ, Robertson D, <i>et al.</i> Comparison of methotrexate monotherapy with a combination of methotrexate and etanercept in active, early, moderate to severe rheumatoid arthritis (COMET): a randomised, double-blind, parallel treatment trial. <i>Lancet</i> 2008; 372 (9636):375–82.	1
European Medicines Agency. <i>Assessment report for Remicade</i> [Internet]: London: EMEA; 2007.	1
European Medicines Agency. <i>Assessment report for Enbrel</i> [Internet]: London: EMEA; 2008.	1
European Medicines Agency. <i>Assessment report for Humira</i> [Internet]: London: EMEA; 2008.	1
European Medicines Agency. <i>Humira EMEA/H/C/481/II/06: scientific discussion</i> [Internet]: London: EMEA; 2004.	1
European Medicines Agency. <i>Humira EMEA/H/C/481/II/21: scientific discussion</i> [Internet]: London: EMEA; 2005.	1
European Medicines Agency. <i>Humira EMEA/H/C/481/II/22: scientific discussion</i> [Internet]: London: EMEA; 2005.	1
European Medicines Agency. <i>Humira EMEA/H/C/481/II/38: scientific discussion</i> [Internet]: London: EMEA; 2007.	1
European Medicines Agency. <i>Humira EMEA/H/C/481/II/43: scientific discussion</i> [Internet]: London: EMEA; 2007.	1
European Medicines Agency. <i>Humira/Trudexa EMEA/H/C/481–482/II/33: scientific discussion</i> [Internet]: London: EMEA; 2007.	1
European Medicines Agency. <i>Product information: Enbrel</i> [Internet]: London: EMEA; 2009.	1
European Medicines Agency. <i>Product information: Humira</i> [Internet]: London: EMEA; 2009.	2
European Medicines Agency. <i>Product information: Remicade</i> [Internet]: London: EMEA; 2009.	2
European Medicines Agency. <i>Remicade EMEA/H/C/240/II/65: scientific discussion</i> [Internet]: London: EMEA; 2006.	1
European Medicines Agency. <i>Remicade EMEA/H/C/240/II/73: scientific discussion</i> [Internet]: London: EMEA; 2006.	1
European Medicines Agency. <i>Remicade EMEA/H/C/240/II/100: scientific discussion</i> [Internet]: London: EMEA; 2007.	1
European Medicines Agency. <i>Scientific discussion</i> [Internet]. London: EMEA; 2004.	1
European Medicines Agency. <i>Scientific discussion</i> [Internet]. London: EMEA; 2004.	1
European Medicines Agency. <i>Scientific discussion</i> [Internet]. London: EMEA; 2005.	1
Food and Drug Administration. <i>Approval package for: application number: BL 103772/1007</i> [Internet]. Rockville, MD: US Food and Drug Administration, Center for Drug Evaluation and Research; 2000.	1
Food and Drug Administration. <i>Approval package for: application number: 103795/S-5097</i> [Internet]. Rockville, MD: US Food and Drug Administration, Center for Drug Evaluation and Research; 2003.	1
Food and Drug Administration. <i>Approval package for: application number: 103795/S-5109</i> [Internet]. Rockville, MD: US Food and Drug Administration, Center for Drug Evaluation and Research; 2003.	1
Food and Drug Administration. <i>Medical review(s)</i> . Approval package for: application number 103795/5123 [Internet]. Rockville, MD: US Food and Drug Administration, Center for Drug Evaluation and Research; 2003.	1
Food and Drug Administration. <i>Medical review(s)</i> . Application number: sBLA 125057/110 [Internet]. Rockville, MD: US Food and Drug Administration, Center for Drug Evaluation and Research; 2008.	1
Food and Drug Administration. <i>Medical/statistical review(s)</i> . Approval package for application number STN 103795/5102 [Internet]. Rockville, MD: US Food and Drug Administration, Center for Drug Evaluation and Research; 2003.	1
Food and Drug Administration. <i>Review of BLA submission 98–0012</i> [Internet]: Rockville, MD: US Food and Drug Administration, Center for Biologic Evaluation and Research; 1998.	1
Food and Drug Administration. <i>Review of BLA submission 99–0 128. Infliximab (REMICADE) for signs and symptoms of rheumatoid arthritis</i> [Internet]. Rockville, MD: US Food and Drug Administration, Center for Biologic Evaluation and Research; 1999.	1
Food and Drug Administration. <i>Risk assessment and risk mitigation review(s)</i> . Application number: sBLA 125057/110 [Internet]. Rockville, MD: US Food and Drug Administration, Center for Drug Evaluation and Research; 2008.	1
Food and Drug Administration. <i>Statistical review</i> . Application number: sBLA 125057/110 [Internet]. Rockville, MD: US Food and Drug Administration, Center for Drug Evaluation and Research; 2008.	1
Furst DE, Schiff MH, Fleischmann RM, Strand V, Birbara CA, Compagnone D, <i>et al.</i> Adalimumab, a fully human anti-tumor necrosis factor-alpha monoclonal antibody, and concomitant standard antirheumatic therapy for the treatment of rheumatoid arthritis: results of STAR (Safety Trial of Adalimumab in Rheumatoid Arthritis). <i>J Rheumatol</i> 2003; 30 (12):2563–71.	1
Gartlehner G, Hansen RA, Jonas BL, Thieda P, Lohr KN. The comparative efficacy and safety of biologics for the treatment of rheumatoid arthritis: a systematic review and metaanalysis. <i>J Rheumatol</i> 2006; 33 (12):2398–408.	4
Goekoop-Ruiterman YPM, De Vries-Bouwstra JK, Allaart CF, Van Zeben D, Kerstens PJSM, Hazes JMW, <i>et al.</i> Comparison of treatment strategies in early rheumatoid arthritis: a randomized trial. <i>Ann Intern Med</i> 2007; 146 (6):406–15.	1
Gordon KB, Gottlieb AB, Leonardi CL, Elewski BE, Wang A, Jahreis A, <i>et al.</i> Clinical response in psoriasis patients discontinued from and then reinitiated on etanercept therapy. <i>J Dermatolog Treat</i> 2006; 17 (1):9–17.	1
Kamm MA. Safety issues relating to biological therapies, with special reference to infliximab therapy. <i>Research and Clinical Forums</i> 2002; 24 (1):79–86.	4

continued

Study	Reason for exclusion ^a
Keane J, Gershon S, Wise RP, Mirabile-Levens E, Kasznica J, Schwieterman WD, <i>et al.</i> Tuberculosis associated with infliximab, a tumor necrosis factor alpha-neutralizing agent. <i>N Engl J Med</i> 2001; 345 (15):1098–104.	1
Keystone EC, Kavanaugh AF, Sharp JT, Tannenbaum H, Hua Y, Teoh LS, <i>et al.</i> Radiographic, clinical, and functional outcomes of treatment with adalimumab (a human anti-tumor necrosis factor monoclonal antibody) in patients with active rheumatoid arthritis receiving concomitant methotrexate therapy: a randomized, placebo-controlled, 52-week trial. <i>Arthritis Rheum</i> 2004; 50 (5):1400–11.	1
Klareskog L, Van Der Heijde D, De Jager JP, Gough A, Kalden J, Malaise M, <i>et al.</i> Therapeutic effect of the combination of etanercept and methotrexate compared with each treatment alone in patients with rheumatoid arthritis: double-blind randomised controlled trial. <i>Lancet</i> 2004; 363 (9410):675–81.	1
Langley RG, Gupta AK, Cherman AM, Inniss KA. Biologic therapeutics in the treatment of psoriasis. Part 1: review. <i>J Cutan Med Surg</i> 2007; 11 (3):99–122.	4
McLeod C, Bagust A, Boland A, Dagenais P, Dickson R, Dundar Y, <i>et al.</i> Adalimumab, etanercept and infliximab for the treatment of ankylosing spondylitis: a systematic review and economic evaluation. <i>Health Technol Assess</i> 2007; 11 (28).	4
Mikuls TR, Weaver AL. Lessons learned in the use of tumor necrosis factor-alpha inhibitors in the treatment of rheumatoid arthritis. <i>Curr Rheumatol Rep</i> 2003; 5 (4):270–7.	4
Montilla Salas J, Munoz Gomariz E, Collantes E. [Meta-analysis of efficacy of anti-TNF alpha therapy in ankylosing spondylitis patients]. <i>Reumatología Clínica</i> 2007; 3 (5):204–12.	4
Moss AC, Farrell RJ. Infliximab for induction and maintenance therapy for ulcerative colitis. <i>Gastroenterology</i> 2006; 131 (5):1649–51.	4
Neven N, Vis M, Voskuyl AE, Wolbink GJ, Nurmohamed MT, Dijkmans BAC, <i>et al.</i> Adverse events in patients with rheumatoid arthritis treated with infliximab in daily clinical practice. <i>Ann Rheum Dis</i> 2005; 64 (4):645–6.	2
Orlando A, Mocchiari F, Civitavecchia G, Scimeca D, Cottone M. Minimizing infliximab toxicity in the treatment of inflammatory bowel disease. <i>Dig Liver Dis</i> 2008; 40 (Suppl. 2):S236–46.	4
Panes J, Gomollon F, Taxonera C, Hinojosa J, Clófent J, Nos P. Crohn's disease: a review of current treatment with a focus on biologics. <i>Drugs</i> 2007; 67 (17):2511–37.	4
Papoutsaki M, Costanzo A, Mazzotta A, Gramiccia T, Soda R, Chimenti S. Etanercept for the treatment of severe childhood psoriasis. <i>Br J Dermatol</i> 2006; 154 (1):181–3.	2
Papp KA. The long-term efficacy and safety of new biological therapies for psoriasis. <i>Arch Dermatol Res</i> 2006; 298 (1):7–15.	4
Pariante A, Gregoire F, Fourrier-Reglat A, Haramburu F, Moore N. Impact of safety alerts on measures of disproportionality in spontaneous reporting databases: the notoriety bias. <i>Drug Saf</i> 2007; 30 (10):891–8.	2
Romero-Mate A, Garcia-Donoso C, Cordoba-Guijarro S. Efficacy and safety of etanercept in psoriasis/psoriatic arthritis: an updated review. <i>Am J Clin Dermatol</i> 2007; 8 (3):143–55.	4
Scheinfeld N. Adalimumab: a review of side effects. <i>Expert Opin Drug Saf</i> 2005; 4 (4):637–41.	4
Subramanian V, Pollok RCG, Kang JY, Kumar D. Systematic review of postoperative complications in patients with inflammatory bowel disease treated with immunomodulators. <i>Br J Surg</i> 2006; 93 (7):793–9.	1
Tyring S, Gottlieb A, Papp K, Gordon K, Leonardi C, Wang A, <i>et al.</i> Etanercept and clinical outcomes, fatigue, and depression in psoriasis: double-blind placebo-controlled randomised phase III trial. <i>Lancet</i> 2006; 367 (9504):29–35.	1
Tyring S, Gordon KB, Poulin Y, Langley RG, Gottlieb AB, Dunn M, <i>et al.</i> Long-term safety and efficacy of 50 mg of etanercept twice weekly in patients with psoriasis. <i>Arch Dermatol</i> 2007; 143 (6):719–26.	3
Van Der Heijde D, Klareskog L, Rodriguez-Valverde V, Codreanu C, Bolosiu H, Melo-Gomes J, <i>et al.</i> Comparison of etanercept and methotrexate, alone and combined, in the treatment of rheumatoid arthritis: two-year clinical and radiographic results from the TEMPO study, a double-blind, randomized trial. <i>Arthritis Rheum</i> 2006; 54 (4):1063–74.	1
Van Der Heijde D, Klareskog L, Landewe R, Bruyn GAW, Cantagrel A, Durez P, <i>et al.</i> Disease remission and sustained halting of radiographic progression with combination etanercept and methotrexate in patients with rheumatoid arthritis. <i>Arthritis Rheum</i> 2007; 56 (12):3928–39.	1
Wallis RS, Broder MS, Wong JY, Hanson ME, Beenhouwer DO. Granulomatous infectious diseases associated with tumor necrosis factor antagonists. <i>Clin Infect Dis</i> 2004; 38 (9):1261–5.	1
Weisman MH, Paulus HE, Burch FX, Kivitz AJ, Fierer J, Dunn M, <i>et al.</i> A placebo-controlled, randomized, double-blinded study evaluating the safety of etanercept in patients with rheumatoid arthritis and concomitant comorbid diseases. <i>Rheumatology</i> 2007; 46 (7):1122–5.	1
Winterfield LS, Menter A. Infliximab. <i>Dermatol Ther</i> 2004; 17 (5):409–26.	2
Winthrop KL, Siegel JN, Jereb J, Taylor Z, Iademarco MF. Tuberculosis associated with therapy against tumor necrosis factor alpha. <i>Arthritis Rheum</i> 2005; 52 (10):2968–74.	4
Wong A, Fonseca MCM, Sandron CA. [Descriptive analyses of safety data for anti-TNF therapies using related outcomes from Uppsala Monitoring Centre (UMC) of World Health Organization (WHO).] <i>Rev Bras Med</i> 2007; 64 (7):323–33.	1

a Reasons for exclusion: 1, not relevant drug or no denominator; 2, <500 patients receiving biologic; 3, does not report adverse events; 4, an overview/systematic review of adverse events.

Appendix 5

Evidence synthesis overview

Background

A Bayesian MTC (indirect comparison) is an extension of a meta-analysis, but where a meta-analysis includes only *direct* evidence an MTC analysis draws on both *direct* and *indirect* evidence.²⁰⁵ As in a meta-analysis, it is the summary treatment effect from each study that is utilised in the MTC analysis; hence the benefit of randomisation in each study is retained.

A standard meta-analysis combines the results from two or more studies that have comparable populations, interventions, comparators and outcomes. Study quality and other study characteristics are also assumed to be similar. Similarly, to make indirect comparisons, it is assumed that the study characteristics are comparable. This is known as *exchangeability*, which can be investigated through the consistency of the direct and indirect evidence.²⁰⁶

These types of evidence syntheses require a 'network of evidence' between all the treatments of interest. In the context of the present review this would mean that the network is required to comprise trials of adalimumab, etanercept, infliximab and placebo, where each treatment has been compared either directly or indirectly with every other. For example, although adalimumab and etanercept may not have been directly compared within a single trial, they can be compared *indirectly* if both have been assessed against a common comparator, placebo. The common comparator need not be placebo and, within a MTC, there can be more than one common comparator. Within a MTC *all* of the available trials' data on a treatment for the specified indication should be included.

In the present analysis all six trials compared one of the three biologics with placebo. Several outcomes were deemed clinically relevant to determining the effectiveness of the biologics and a Bayesian indirect comparison was conducted for each of these outcomes. All included trials were assessed as part of the clinical review and it was determined that the population, intervention protocols, outcomes and other study characteristics were sufficiently exchangeable for synthesis to be conducted. The analysis was undertaken using WINBUGS version 1.4.2.²⁰⁷ WINBUGS is a Bayesian analysis software that, through the use of Monte Carlo Markov chains, calculates posterior distributions for the parameters of interest, given likelihood functions derived from data and prior probabilities. The Monte Carlo Markov chain simulation begins with an approximate distribution and, if the model is a good fit to the data, the distribution converges to the true distribution. For all models used in the present analysis the first 10,000 iterations were considered to be 'burn in' and excluded, and a further 100,000 iterations were performed in order to calculate the results. The WINBUGS codes for the different analyses are presented in WINBUGS code, below. All of the data used in the evidence synthesis are presented in *Tables 41–44*.

An evidence synthesis was conducted for each of the four main outcomes. The primary outcome of this analysis was the probability of response to treatment in terms of PsARC (PsARC response) at 12 weeks following the BSR guidelines. The changes in HAQ score are conditional on a PsARC response to treatment, the probability of achieving the PASI 50/75/90 response, and the probability of achieving the ACR 20/50/70 response were also calculated. Three different models

were produced to allow the separate outcomes to be synthesised. An overview of each model, along with the formal model is presented in the following section.

Psoriatic Arthritis Response Criteria response

The probability of initial response to each treatment, as determined by the PsARC outcome at 12 weeks, was modelled using a common-effects meta-analysis. Outcomes at 14 weeks were included in the analysis and assumed equivalent to outcomes at 12 weeks. Data were available from all six trials (two for each active treatment) for this outcome measure (see *Table 41*). Each trial reported the number of events in the control group (r_i^C) and the number of events under active treatment (r_i^T), where i represents a trial ($i = \text{Fleischmann } et al.,^{99} \text{ Kavanaugh } et al.,^{109} \text{ Lebowhl } et al.,^{105} \text{ Mease},^{52,78,97} \text{ Wanke } et al.,^{107} \text{ IMPACT},^{79} \text{ IMPACT 2},^{82} \text{ ADEPT},^{51} \text{ Genovese } et al.^{83}$). It was assumed that both r_i^C and r_i^T are binomially distributed.

The common baseline for each treatment effect was the probability of response to placebo. In order to achieve this, a meta-analysis on the placebo arms of the six RCTs was conducted. Each of the individual studies estimate the same true treatment effect δ_i (i.e. the underlying effect), and that differences between studies are solely due to chance. The observed effect of each study equals a fixed effect that is common to all studies plus sampling error;²⁰⁸ In the Bayesian evidence synthesis, δ_i was assigned a non-informative normal prior distribution. Formally:

$$r_i^C \sim \text{Binomial}(p_i^C, n_i^C)$$

$$r_i^T \sim \text{Binomial}(p_i^T, n_i^T)$$

$$\text{Logit}(p_i^C) = \mu_i$$

$$\text{Logit}(p_i^T) = \mu_i + \delta_i$$

Treatment effects on probability of response were additive to the placebo probability of response on the log-odds scale. The probability of response to the intervention is given by:

$$P(\text{Response}_k) = \frac{\exp(T_k)}{1 + \exp(T_k)}$$

with $T_k = \mu + \delta_k$ being the treatment effect on the intervention k ($k = \text{placebo, etanercept, infliximab, adalimumab}$) and being the true treatment effect of the intervention k (on a log-odds scale).

The common effects model was compared with a random-effects model for both fit, as measured by the deviation information criterion (DIC), convergence and correlation. The data for these models are presented in *Table 41*. The DIC statistic combines model deviance and the effective number of parameters. The DIC statistics were very similar: 128.288 for the common-effects model versus 128.274 for the random-effects model. Convergence and autocorrelation were assessed using graphical tools available within WINBUGS. The common-effects model was a good fit, converged well and did not display any issues with autocorrelation. The random-effects model did not converge well and displayed issues with autocorrelation. For these reasons the common-effects model was used.

TABLE 41 PsARC model data inputs

Study	Treatment	Response	<i>n</i>
Mease 2000 ⁷⁸	Placebo	7	30
	Etanercept	26	30
Mease 2004 ^{52,97,99,105,107,110}	Placebo	32	104
	Etanercept	73	101
IMPACT ⁷⁹	Placebo	7	52
	Infliximab	40	52
IMPACT 2 ⁸²	Placebo	27	100
	Infliximab	77	100
ADEPT ⁵¹	Placebo	42	162
	Adalimumab	94	151
Genovese 2007 ⁸³	Placebo	12	49
	Adalimumab	26	51

Changes in Health Assessment Questionnaire

Trials that reported the absolute changes in HAQ from baseline, conditional on whether the patient responds to therapy at 12 weeks were modelled using a random-effects meta-analysis. Data were available from five of the six trials for this outcome measure: etanercept data were not available from the Mease *et al.*⁷⁸ trial.

Let 'TR' be the treatment responders, 'TNR' be the treatment non-responders, 'PR' be the placebo responders and 'PNR' be the placebo non-responders. Also, let *i* represent the trial and *j* the alternative treatments. We have assumed changes in HAQ given placebo non-responders as common baseline (μ_{PNR}) – a non-informative normal distribution was assigned to this parameter. The effects of treatment response ($\delta.diff_{TRij}$) and non-response ($\delta.diff_{TNRij}$) on HAQ change are assumed to be treatment specific and additive to the placebo probability of non-response on the log-odds scale as illustrated below:

$$\mu_{PNRi} = \text{baseline}$$

$$\mu_{PRi} = \mu_{PNRi} + \delta.diff_{PRi}$$

$$\mu_{TNRi} = \mu_{PNRi} + \delta.diff_{TNRij}$$

$$\mu_{TRi} = \mu_{PNRi} + \delta.diff_{TRij}$$

For each of the different trials the true effect may be study specific and vary across studies although remain common across biologics. These true effects are described by a normal distribution. Hence, the variation in observed individual study results is caused not only by sampling error (as with the common-effects approach), but also by the variation in the true (underlying) effects of each study.²⁰⁹

When estimating HAQ separately for those who responded to PsARC we investigated a number of alternative modelling scenarios including:

- a fixed-effects model, assuming that all biologics have the same effectiveness after conditioning on PsARC response

- a random-effects model, assuming that all biologics have the same effectiveness after conditioning on PsARC response, and that heterogeneity in effects is the same for responders and non-responders
- a random-effects model with all biologics having different (non-related) effectiveness after conditioning on PsARC response, assuming heterogeneity in effects is the same for responders and non-responders
- a random-effects model assuming that all biologics have the same effectiveness after conditioning on PsARC response, including a response effect as a fixed effect and an interaction term to allow treatment/response interaction.

Due to the volume of data informing the synthesis, and the need to derive clinically relevant estimates for the economic model, the decision was made to limit the choice to a fixed/common-effects model, assuming all biologics have the same effectiveness (after conditioning on PsARC response) and a random effects model, with all biologics having different (non-related) effectiveness (after conditioning on PsARC response), while assuming heterogeneity in effects is the same for responders and non-responders. Finally, two alternative modelling scenarios were tested in an attempt to identifying the most appropriate model. The data for these two alternatives are presented in *Table 42*. The DIC statistic, convergence and autocorrelation were all assessed and informed model selection. The DIC statistics were -42.925 for the random-effects model and -55.095 for the fixed/common-effects model. As there was no issues with convergence or autocorrelation, the random-effects model was selected for use in the base weeks of the economic decision model, and the common treatment effect evidence synthesis estimate was used in a sensitivity analysis of the economic decision model. The results of the common effect model have been presented in *Table 45* at the end of this appendix, not in the main clinical chapter.

Psoriatic Arthritis Response Criteria 50/75/90

Data were available from five of the six trials for this outcome measure: adalimumab data were not available from the Genovese *et al.* trial.⁸³ All responses are measured at 12–16 weeks apart from the IMPACT 2 trial,^{82,90,91,95,98,106,112,116} which reported only PASI responses at 24 weeks. A coefficient was included in the linear predictor to estimate whether the difference in follow-up time for this trial was significant. The probability of response in terms of the PASI 50/75/90 scores was modelled using an ordered multinomial logit model. In the ordered logit model the probability of an outcome is calculated by estimating a latent variable as a linear function of the independent variable plus a set of thresholds/cut-off points. In this analysis these thresholds represent the different outcomes of PASI 50/75/90. The probability of observing the latent variable equals the probability that the estimated linear function is within the cut-off points estimated for the outcome. This type of model allows the ordered nature of the outcomes to be

TABLE 42 Health Assessment Questionnaire|PsARC model inputs

HAQ given PsARC response		SE	HAQ given no PsARC response		SE
Placebo	-0.258	0.006	Placebo	-0.002	0.042
Etanercept	-0.635	0.062	Etanercept	-0.196	0.072
Placebo	-0.27	0.14	Placebo	0.02	0.05
Infliximab	-0.65	0.09	Infliximab	-0.2	0.09
Placebo	-0.16	0.096	Placebo	0.07	0.042
Infliximab	-0.58	0.057	Infliximab	-0.11	0.06
Placebo	-0.3134	0.0761	Placebo	0.0260	0.0366
Adalimumab	-0.5	0.0445	Adalimumab	-0.1198	0.0525
Placebo	-0.1771	0.0624	Placebo	-0.0574	0.0530
Adalimumab	-0.4231	0.0809	Adalimumab	-0.1500	0.0904

maintained. Outcomes estimated are the probability of achieving each of the three PASI levels. A number of assumptions were made to facilitate modelling:

- A common-effects model was used to estimate baseline; this was estimated using data from placebo non-responders (i.e. those receiving placebo and not achieving PASI 50).
- Common effects were assumed for each treatment class (etanercept, infliximab and adalimumab).
- Thresholds were assumed to be fixed across trials.
- The baseline latent variable was assumed fixed.

The response of a patient to treatment for psoriasis is measured using the PASI scoring system. The RCTs typically measure the change in psoriasis in each participant by comparing the percentage change in PASI with the score at baseline, and report the number of patients who achieved the following responses, in trial i and treatment j , where $j=0$ is placebo, and $j=1, 2, 3$ are the three biologic therapies:

- PASI 50 _{ij} is at least a 50% change.
- PASI 75 _{ij} is at least a 75% change.
- PASI 90 _{ij} is at least a 90% change.

The statistical analysis used a multicategorical response model to analyse these data. The multivariate response variable r_{ij} is a vector of the number of participants in arm j of study i reporting one of the four possible values:

$R_{ij1} = N_{ij} - \text{PASI } 50_{ij}$, or the number not achieving PASI 50.

$R_{ij2} = \text{PASI } 50_{ij} - \text{PASI } 75_{ij}$, the number achieving PASI 50, but not PASI 75.

$R_{ij3} = \text{PASI } 75_{ij} - \text{PASI } 90_{ij}$, the number achieving PASI 75, but not PASI 90.

$R_{ij4} = \text{PASI } 90_{ij}$, the number achieving PASI 90.

In a trial arm of size N_{ij} , r_{ij} is multinomially distributed:

$$r_{ij} \sim M(N_{ij}, p_{ij})$$

where

$$r_{ij} = (R_{ij1}, \dots, R_{ij4}), p_{ij} = (P_{ij1}, \dots, P_{ij4}) \text{ and}$$

$$P_{ijr} = \Pr(R_{ij} = r | x_{ij})$$

We estimate the probability that patients have a PASI 50, 75 or 90 response by a cumulative logistic model. We define Z_{ij} to be a latent variable representing the mean improvement in psoriasis in arm j of trial i . The latent variable is determined by the explanatory variables in a linear form:

$$Z_{ij} = a_i + b_j x_{ij} + e_{ij} = a_i + b_1 T_{i1} + b_2 T_{i2} + b_3 T_{i3} + e_{ij}$$

Where a_i represents the mean improvement in the placebo arm of trial i and coefficient b_j represents the mean improvement that can be attributed to treatment j , for $j=1, 2, 3$, and T_{ij} is a dummy variable for the biologic that was trialled in RCT i . Coefficient a_i is a fixed-effects for

trial i and coefficient b_j is assumed to be common across all trials for treatment j . As this is an ordered logit model, coefficient b_j can be interpreted as the log-treatment effect of drug j relative to placebo.

R and Z are connected by:

$$r_{ij} = r \leftrightarrow \theta_r < Z_{ij} < \theta_{r+1}$$

for $r=2, 3, 4$ where

$$-\infty = \theta_1 < \theta_2 < \theta_3 < \theta_4 < \theta_5 = \infty$$

The parameters θ_r represent thresholds for observing a particular psoriasis response, rather than a less strong response. The error term e_{ij} was assumed to take a logistic distribution function $Pr(e_{ij} \leq e) = F(e) = 1/[1 + \exp(-e)]$.

We define variable Y_{ijr} to be the cumulative probability of achieving a response r or greater, so that Y_{ij1} is the probability of a patient achieving a PASI 50 response in trial i and treatment j , Y_{ij2} is the probability of achieving a PASI 75 response, and Y_{ij3} the probability of achieving a PASI 90 response.

Therefore,

$$\begin{aligned} Y_{ijr} &= 1 - Pr(r_{ij} \leq r | x_{ij}) \\ &= Pr(Z_{ij} > \theta_{r+1}) = Pr(a_i + b_j x_{ij} + e_{ij} > \theta_{r+1}) \\ &= Pr[e_{ij} > \theta_{r+1} - (a_i + b_j x_{ij})] \\ &= Pr\{e_{ij} \leq -[\theta_{r+1} - (a_i + b_j x_{ij})]\} \\ &= F\{-[\theta_{r+1} - (a_i + b_j x_{ij})]\}, \text{ for } r=2, 3 \end{aligned}$$

Parameter θ_2 is not estimated as it is co-linear with the intercept term.

It follows that:

$$\begin{aligned} \text{Logit}(Y_{ij1}) &= a_i + b_j x_{ij} \\ \text{Logit}(Y_{ij2}) &= a_i + b_j x_{ij} - \theta_3 \\ \text{Logit}(Y_{ij3}) &= a_i + b_j x_{ij} - \theta_4 \end{aligned}$$

To avoid problems with estimation that may occur if the thresholds are very similar, the thresholds θ_3 and θ_4 were reparameterised by²¹⁰ $\theta_3 = \omega_3$ and $\theta_4 = \omega_3 + \exp(\omega_4)$.

In the Bayesian evidence synthesis, all parameters of the model (a_j , b_j , and ω_r) were assigned non-informative normal prior distributions.

One of the aims of the model was to provide predictions of PASI 50/75/90 response rates for each treatment. This requires an estimate of parameter a , the intercept of the linear latent variable function. This was made by assuming it is equivalent to the pooled (mean) log-odds of a PASI 50 response across all the placebo arms of the RCTs.

As with the other evidence synthesis models, different modelling scenarios were assessed using criteria such as the DIC statistic, convergence and autocorrelation graphs. These models included an ordered probit model and random-effects versions of both the ordered logit and probit. The model selected was the best fit and presented good convergence and no sign of autocorrelation. The data for these models are presented in *Table 43*. The ordered logit models both had lower DIC statistics than the ordered probit models: 146.301 for the common effects versus 147.421

TABLE 43 PASI model data inputs

Trial	Treatment	Outcome (% change in PASI)	<i>n</i>		
Mease 2000 ⁷⁸	Placebo	< 50	15		
		50–75	4		
		75	0		
		> 90	<i>No data</i>		
	Etanercept	< 50	11		
		50–75	3		
		75	5		
		> 90	<i>No data</i>		
		Mease 2004 ⁵²	Placebo	< 50	51
				50–75	9
75–90	0				
> 90	2				
Etanercept	< 50		35		
	50–75		16		
	75–90		11		
	> 90		4		
	IMPACT ^{79–81,89,96,109,111,113–115,117,118}		Placebo	< 50	16
				50–75	0
75–90		0			
> 90		0			
Infliximab		< 50	0		
		50–75	7		
		75–90	7		
		> 90	8		
		IMPACT 2 ^{82,90,91,95,98,106,112,116}	Placebo	< 50	79
				50–75	6
75–90	2				
> 90	0				
Infliximab	< 50		15		
	50–75		15		
	75–90		19		
	> 90		34		
	ADEPT ⁵¹		Placebo	< 50	59
				50–75	7
75–90		3			
> 90		0			
Adalimumab		< 50	19		
		50–75	16		
		75–90	13		
		> 90	21		

for the random effects. As with other models, issues with convergence and autocorrelation made the common effects a better choice. The ordered probit models, although behaving quite well in terms of convergence did show signs of autocorrelation. Additionally, both the common- and random-effects models produced DIC statistics in excess of 1800.

American College of Rheumatology 20/50/70

Data were available from all of the six trials for this outcome, across all three thresholds. As with the PASI data, the ACR data were modelled using an ordered multinomial logit model.

The same set of modelling assumptions that were applied to the PASI model was used for the ACR model. As stated previously, different modelling scenarios were assessed using criteria such as the DIC statistic, convergence and autocorrelation graphs. These models included an ordered probit model and random-effects versions of both the ordered logit and probit. The model selected was the best fit, and presented good convergence and no sign of autocorrelation. The data for these models are presented in *Table 44*. Like the PASI models, the ACR ordered probit models behaving well in terms of convergence although they also showed signs of autocorrelation. They again produced DIC statistics in excess of 1800. Both the ordered logit models both had lower DIC statistics: 200.88 for the common effects and 202.069 for the random effects. Again, the random-effects model having some issues with autocorrelation, hence making the common effects model a better choice.

The formal model for the ACR data is extremely similar to the PASI model outlined above.

Results for Health Assessment Questionnaire/Psoriatic Arthritis Response Criteria common effect

Table 45 shows the results for the evidence synthesis of HAQ conditional on PsARC response assuming that all three biologics have the same underlying treatment effect. The results are presented here as they were used in a sensitivity analysis scenario in the economic decision model.

TABLE 44 American College of Rheumatology model data inputs

Trial	Treatment	Outcome (% change in ACR data)	n
Mease 2000 ⁷⁸	Placebo	<20	26
		20–50	3
		50–75	1
		>75	0
	Etanercept	<20	8
		20–50	7
		50–75	11
		>75	4
Mease 2004 ^{52,97,99,105,107,110}	Placebo	<20	88
		20–50	12
		50–75	4
		>75	0
	Etanercept	<20	41
		20–50	22
		50–75	27
		>75	11
IMPACT ^{79–81,89,96,109,111,113–115,117,118}	Placebo	<20	46
		20–50	5
		50–75	1
		>75	0
	Infliximab	<20	17
		20–50	16
		50–75	8
		>75	11
IMPACT 2 ^{82,90,91,95,98,106,112,116}	Placebo	<20	89
		20–50	8
		50–75	2
		>75	1
	Infliximab	<20	42
		20–50	22
		50–75	21
		>75	15
ADEPT ^{51,88,92,93,100–104}	Placebo	<20	139
		20–50	17
		50–75	5
		>75	1
	Adalimumab	<20	63
		20–50	34
		50–75	24
		>75	30
Genovese 2007 ⁸³	Placebo	<20	41
		20–50	7
		50–75	1
		>75	0
	Adalimumab	<20	31
		20–50	7
		50–75	6
		>75	7

TABLE 45 Health Assessment Questionnaire|PsARC common treatment effect

HAQI response: common treatment effects (common baseline)	Mean	Credible interval (%)	
		2.50	97.50
Treatment changes in HAQI response	-0.5688	-0.6305	-0.5073
Treatment changes in HAQI no response	-0.1697	-0.2362	-0.1038
Placebo changes in HAQI response	-0.2606	-0.3149	-0.2062

WINBUGS code**Evidence synthesis models** WINBUGS code

Model one: probability of PsARC response to each treatment (and placebo)

```

model
{
  for (i in 1:N) #Calculate Odds Ratios
  {
    r[i]~dbin(p[i], n[i]) # Likelihood
    logit(p[i])<-mu[s[i]]+delta[i]*(1-equals(t[i],b[i]))# Model
    delta[i] ~ dnorm(m[i], prec) # Distribution of specif LORs
    m[i]<-d[t[i]]-d[b[i]] # Mean of study-specific LORs
  }
  for (j in 1:NS)
  {
    mu[j]~dnorm(0,1.0E-6) # Vague priors for trial baselines
  }
  d[1]<-0
  for (k in 2:4)
  {
    d[k]~dnorm(0,1.0E-6) # Vague priors for basic parameters
    OR[k]<-exp(d[k])
  }
  # Meta-analysis on the placebo arms to get a baseline treatment effect (and probability of
  response) of placebo
  for (j in 1:NS)
  {
    rplac[j]~dbin(pplac[j],nplac[j]) # control response
    logit(pplac[j])<-mp[j]
    mp[j]~dnorm(Mean,Tau)
  }
  Tau<-1/(sigma*sigma)
  sigma~dunif(0,10)
  Mean~dnorm(0,0.000001)
  Prob.response.plac <- exp(Mean)/(1+exp(Mean))
  #Calculate treatment effects, T[k], on natural scale
  for (k in 2:4)
  {
    T[k] <- Mean + d[k]
    prob[k]<-exp(T[k])/(1+exp(T[k])) #Probability of response
  }
}
#end model

```

Model two: Health Assessment Questionnaire conditional on Psoriatic Arthritis Response Criteria response

```

model {
  for (i in 1:5) {
    ### Converting standard errors into precisions
    prec.HAQ.TR[i] <- 1/(se.HAQ.TR[i] * se.HAQ.TR[i])
    prec.HAQ.PR[i] <- 1/(se.HAQ.PR[i] * se.HAQ.PR[i])
    prec.HAQ.TNR[i] <- 1/(se.HAQ.TNR[i] * se.HAQ.TNR[i])
    prec.HAQ.PNR[i] <- 1/(se.HAQ.PNR[i] * se.HAQ.PNR[i])
    ### Likelihood for data
    HAQ.TR[i] ~ dnorm(response.trt[i], prec.HAQ.TR[i])
    HAQ.PR[i] ~ dnorm(response.plac[i], prec.HAQ.PR[i])
    HAQ.TNR[i] ~ dnorm(no.response.trt[i], prec.HAQ.TNR[i])
    HAQ.PNR[i] ~ dnorm(no.response.plac[i], prec.HAQ.PNR[i])
    ### Simple meta-analysis model
    baseline.HAQ[i] ~ dnorm(0, 0.0000001)
    no.response.plac[i] <- baseline.HAQ[i]
    response.plac[i] <- baseline.HAQ[i] + delta.plac.diff.response[i]
    no.response.trt[i] <- baseline.HAQ[i] + delta.trt.diff.no.response[trial.tnf[i],i]
    response.trt[i] <- baseline.HAQ[i] + delta.trt.diff.response[trial.tnf[i],i]
    ### Vague prior distributions
    delta.trt.diff.response[trial.tnf[i],i] ~ dnorm(trt.diff.response[trial.tnf[i]], inv.tau.sq)
    delta.trt.diff.no.response[trial.tnf[i],i] ~ dnorm(trt.diff.no.response[trial.tnf[i]], inv.tau.sq)
    delta.plac.diff.response[i] ~ dnorm(plac.diff.response, inv.tau.sq)
  }
  for (j in 1:3) {
    trt.diff.response[j] ~ dnorm(0, 1.0E-6)
    trt.diff.no.response[j] ~ dnorm(0, 1.0E-6)
  }
  plac.diff.response ~ dnorm(0, 1.0E-6)
  inv.tau.sq <- 1/(sigma * sigma)
  sigma ~ dunif(0, 10)
  for (i in 1:5) {
    HAQ.PNR[i] ~ dnorm(mu, inv.tau.sq.b) #Likelihood
    mu ~ dnorm(0, 0.000001) #Prior for mu
    inv.tau.sq.b <- 1/(sigma.b * sigma.b)
    sigma.b ~ dunif(0, 10)
  }
}
#end model

```

Model three: probability of achieving Psoriasis Area and Severity Index response

```

#ordered multinomial logit
model #Fixed treatment effects
{
  for (i in 1:8) { #4 trials x 2 arms
    R[i,1:4] ~ dmulti(p[i,], N[i]) #multinomial likelihood
    #Y[i,] is the cumulative density function of the error term of a continuous latent variable
    representing PASI change from the start of the trial in trial i
    z[i,1] <- aa[Trial[i]] + b[1]*E[i] + b[2]*A[i] + b[3]*I[i] +
    w24*offset[i] #linear predictor of latent variable
    #assume logistic distribution for error term
    logit(Y[i,1]) <- -z[i,1]
  }
}

```

```

#first threshold (PASI >50) differing across trials with a[trial[i]]
logit(Y[i,2])<- -(z[i,1] +exp(theta[1]))
#second threshold PASI >75
logit(Y[i,3])<- -(z[i,1] +exp(theta[1])+exp(theta[2]))
# third threshold PASI>90
#exp(theta 1) and exp (theta 2) ensures that the gaps between thresholds are strictly positive
p[i,1]<-1-Y[i,1] #PASI CHANGE LESS THAN 50
p[i,2]<-Y[i,1]-Y[i,2] #PASI CHANGE 50 TO 74
p[i,3]<-Y[i,2]-Y[i,3] #PASI CHANGE 75 TO 89
p[i,4]<-Y[i,3] #PASI CHANGE >90
}
w24~dnorm(0,1.0E-6)
for (t in 1:3){
b[t]<-m[t] #fixed effects for each treatment
m[t]~dnorm(0,1.0E-6)
}
for (c in 1:2){ # thresholds
theta[c]~dnorm(0,0.00001)
}
#other data: trial 1 reports number with PASI change 50 & 75 but not other PASI thresholds
r.pasi50[1]~dbin(Y[9,1], n[1])
r.pasi50[2]~dbin(Y[10,1], n[2])
r.pasi75[1]~dbin(Y[9,2], n[1])
r.pasi75[2]~dbin(Y[10,2], n[2])
z[9,1]<- aa[1] #Baseline of trial number 1: placebo arm
z[10,1]<- aa[1]+b[1] #Treatment effect of trial 1
logit(Y[9,1]) <- -z[9,1]
#prediction of what PASI >50 would have been in placebo arm of trial
logit(Y[10,1]) <- -z[10,1]
#prediction of what PASI >50 would have been in trt arm of trial
logit(Y[9,2]) <- -(z[9,1] +exp(theta[1]))
#PASI>75 in this trial in placebo arm
logit(Y[10,2]) <- -(z[10,1]+ exp(theta[1]))
#PASI>75 in trt arm
logit(Y[9,3]) <- -(z[9,1] +exp(theta[1])+exp(theta[2])) #prediction of PASI>90 in plac arm of
trial
logit(Y[10,3]) <- -(z[10,1]+ exp(theta[1])+exp(theta[2]))
#prediction of PASI>90 in trt arm of trial
for (i in 1:5){
#latent baseline
aa[i]~dnorm(0,1.0E-6)
}
#baseline
for (j in 1:5) # trials
{
rplac[j]~dbin(pplac[j],nplac[j]) # control response
logit(pplac[j])<-a
}
a~dnorm(0,0.000001)
Prob.response.plac <- exp(a)/(1+exp(a))
#predictions for treatment + placebo group
z.mn[1]<-a

```

```

z.mn[2]<-(a+m[1])#etanercept
z.mn[3]<-(a+m[2])#adalimumab
z.mn[4]<-(a+m[3])#infliximab
for (t in 1:4){
logit(Pr[t,1])<- -z.mn[t]
#first threshold (PASI >50)
logit(Pr[t,2])<- -(z.mn[t] +exp(theta[1]))
#second threshold PASI >75
logit(Pr[t,3])<- -(z.mn[t] +exp(theta[1])+exp(theta[2]))
# third threshold PASI>90
}
}
#end model

```

Model four: probability of achieving American College of Rheumatology response

```

ordered multinomial logit
model { #Fixed treatment effects
for(i in 1:12){ #6 trials x 2 arms
R[i,1:4]~dmulti(p[i,],N[i]) #multinomial likelihood
#Y[i,] is the cumulative density function of the error term of a continuous latent variable
representing ACR change from the start of the trial in trial i
z[i,1]<-aa[Trial[i]]+ b[1]*E[i]+b[2]*A[i]+b[3]*I[i]
#linear predictor of latent variable
#assume logistic distribution for error term
logit(Y[i,1])<- -z[i,1]
#first threshold (ACR >20) differing across trials with a[trial[i]]
logit(Y[i,2])<- -(z[i,1] +exp(theta[1]))
#second threshold ACR >50
logit(Y[i,3])<- -(z[i,1] +exp(theta[1])+exp(theta[2]))
# third threshold ACR>70
#exp(theta 1) and exp (theta 2) ensures that the gaps between thresholds are strictly positive
p[i,1]<-1-Y[i,1]#ACR CHANGE LESS THAN 20
p[i,2]<-Y[i,1]-Y[i,2]#ACR CHANGE 20 TO 49
p[i,3]<-Y[i,2]-Y[i,3]#ACR CHANGE 50 TO 69
p[i,4]<-Y[i,3] #ACR CHANGE >70
}
for (t in 1:3){ #fixed effects for each treatment
b[t]<-m[t]
m[t]~dnorm(0,1.0E-6)
}
for (c in 1:2){# thresholds
theta[c]~dnorm(0,0.00001)
}
for (i in 1:6){ #latent baseline
aa[i]~dnorm(0,1.0E-6)
}
#baseline
for (j in 1:6) # trials
{
rplac[j]~dbin(pplac[j],nplac[j]) # control response
logit(pplac[j])<-a

```

```
}
a~dnorm(0,0.000001)
Prob.response.plac <- exp(a)/(1+exp(a))
#predictions for treatment + placebo group
z.mn[1]<-a
z.mn[2]<-(a+m[1])#etanercept
z.mn[3]<-(a+m[2])#adalimumab
z.mn[4]<-(a+m[3])#infliximab
for (t in 1:4){
logit(Pr[t,1])<- -z.mn[t]
#first threshold (ACR >20)
logit(Pr[t,2])<- -(z.mn[t] +exp(theta[1]))
#second threshold ACR >50
logit(Pr[t,3])<- -(z.mn[t] +exp(theta[1])+exp(theta[2]))
# third threshold ACR>70
}
}
#end model
```

Appendix 6

Clarifications from manufacturers

Wyeth¹⁵³

Decision to withdraw depending on initial response

The model requires patients to withdraw from biologic therapy if no response is achieved at either 12 or 24 weeks. How are responses at 12 and 24 weeks correlated? Is there a regression model to link response at 12 weeks with response at 24 weeks?

No, it was not possible to include any correlation between the response rates at 12 weeks and 24 weeks, given the evidence available (MTC – STA). Data from a previous published MTC (STA – Adalimumab) was used to model the response rate at either 12 or 24 weeks independently. It is believed that data presented in the MTC for the response rate at 24 weeks is independent to the response at 12 weeks when looking at the sample size of patients included in the MTC. For instance, all of the patients randomised in the etanercept arm in the Mease 2004 trial^{52,97,99,105,107,110} or in the infliximab arm in the IMPACT 2 trial^{82,90,91,95,98,106,112,116} were included at 24 weeks in the MTC, whether or not they responded at 12 weeks. Consequently, this suggests that response rates reported in the MTC at 12 and 24 weeks were not conditional of each other. The response rates at 12 and 24 weeks were therefore sampled independently of each other. It was not possible to sample the response rate jointly (taking into account the correlation) in the absence of patient data for other treatments.

Health Assessment Questionnaire for responders and non-responders

Wyeth¹⁵³ estimates a regression of HAQ given PsARC and PASI (tables 9 and 10). The Assessment Group would like to request that Wyeth¹⁵³ rerun this regression without PASI. This is for two reasons. First, each of the manufacturers has submitted a different model and we would like to compare estimates of parameters from different sources. Wyeth's model¹⁵³ is the only one that uses PASI to predict HAQ. Second, this will enable the York Assessment Group to use Wyeth's data¹⁵³ to inform HAQ in the York economic model.

Our model included PASI to predict HAQ, given the possible correlation between HAQ and PASI. A full regression model, including different covariates, was estimated initially. Non-significant covariates were then excluded (significance level of 0.05). PASI was found to be a significant predictor of HAQ in addition to PsARC. PASI thus explain part of the variance in HAQ in addition to PsARC. Removing PASI would remove part of the explained variance in HAQ. Our method was also justified by the absence of relationship between Cost, HAQ and PASI.

However, as requested by the Assessment Group, regression models for HAQ without PASI were rerun.

The Assessment Group would also like to use the data on mean HAQ conditional on response from the Mease 2004 trial,^{52,97,99,105,107,110} which was commercial-in-confidence (CiC) in the previous NICE appraisal. Please could you consider releasing this data from the CiC restriction?

We are in contact with our Global Medical Affairs department to clarify whether this data can be released from the CiC restriction.

Long-term withdrawal rate from biologics

Wyeth¹⁵³ has estimated Weibull models for the rate of withdrawal from biologics, from data published from the BSR register. The York Assessment Group is not clear what calculations were made to estimate these parameters. Please clarify how these parameters were worked out from the data?

The BSR paper¹⁹¹ reported the proportion of patients on etanercept at 1 year (86%), 2 years (79%) and 3 years (65%). A Weibull curve was fitted to these three values by calibrating the two parameters of the Weibull function (scale and shape) in order to minimise the error between the observed and predicted proportion of patients still treated with etanercept. The observed and predicted proportions of patients treated with etanercept at 1, 2 and 3 years are reported below. The root mean square error between the observed and predicted proportion was 0.01961.

TABLE Observed and predicted proportions of patients treated with etanercept

Year	Observed	Predicted
–	1.00	1.00
1	0.86	0.88
2	0.79	0.76
3	0.65	0.66

The Weibull function was assumed to follow the following equation (as defined in STATA):

$$S(t) = \text{EXP}\{-\text{EXP}(\text{scale}) \times [\text{time}^{\text{EXP}(\text{shape})}]\}$$

Utility conditional on Psoriatic Area and Severity Index and Health Assessment Questionnaire

Wyeth¹⁵³ has presented regression models to predict utility from HAQ and PASI. However, the Assessment Group is unable to easily compare this with the other models because each has used a different source of data and different covariates in the regression. To enable us to compare the submissions, and include estimates from different sources in the York model, we would like to request that you rerun this regression in a comparable way. We suggest the following set of untransformed covariates is included in the regression: Constant, HAQ, PASI and HAQ×PASI (interaction term). We would like to request the results of this regression as coefficients, variance–covariance matrix, number of observations and number of clusters (if appropriate), indicating the source of data.

The regression model to predict utility from PRESTA was rerun to include HAQ, PASI and the interaction between HAQ and PASI as requested by ERG. A second model was also generated without the interaction between HAQ and PASI given the non-significance of the coefficient for the interaction.

Abbott¹⁵¹

Sequencing

The Abbott model¹⁵¹ allows a sequence of DMARDs after failure of biologic therapy. Is there always 10 DMARDs in this sequence? What treatment (or no treatment) is given after failure of the last DMARD in the sequence?

The model¹⁵¹ is structured to allow for a maximum of 10 different DMARD treatments (which includes different combinations of DMARDs). The model¹⁵¹ assumes that patients will continue to try different combinations of DMARDs rather than receive no active treatment. Consequently, no response test is used for DMARD therapies, and patients withdraw from these treatments based on the long-term withdrawal rate. Once the patient reaches the last DMARD combination in the sequence, they have effectively run out of options and so will continue on that treatment until they die.

Long-term withdrawal rate from biologics

Abbott¹⁵¹ has estimated Weibull models for the rate of withdrawal from biologics, from data published from the BSRBR register. The York Assessment Group is not clear what calculations were made to estimate these parameters. Please can you clarify how these parameters were worked out from the data?

A crude survival analysis is made using the reported figures in Table 46 of Saad *et al.*¹⁹¹ As can be seen in Figure 7, the analysis used survival rates reported by Saad *et al.*¹⁹¹ for all biologics in year 1 (0.82), in year 2 (0.70) and in year 3 (0.59). Survival rates beyond the initial 3-year period were modelled assuming a Weibull distribution following the shape of survival curves observed for other rheumatic diseases.²¹¹

Abbott¹⁵¹ has presented a regression model to predict utility from HAQ and PASI. However, the Assessment Group is unable to easily compare your model with the others because each model has used a different source of data and different covariates in the regression. To enable us to compare the submissions, and include estimates from different sources in the York model, we would like to request that you rerun this regression in a comparable way. We suggest the following set of untransformed covariates is included in the regression: Constant, HAQ, PASI and HAQ×PASI (interaction term). We would also like to request the results of this regression as coefficients, variance–covariance matrix, number of observations, number of clusters (if appropriate), indicating the source of data.

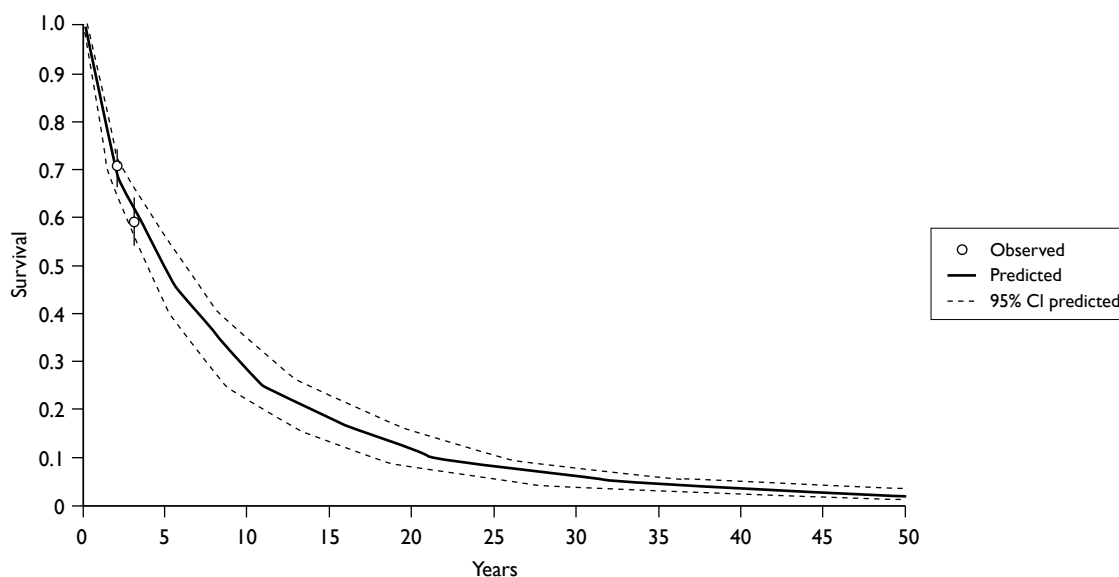

FIGURE 7 Observed versus predicted survival for all biologics. Utility conditional on the PASI and HAQ.

TABLE 46 Utility regression estimates

Parameter	Estimate	SE	95% confidence limits		Z	Probability > Z
Intercept	0.8862	0.0182	0.8506	0.9217	48.82	<.0001
HAQ	-0.2317	0.0248	-0.2803	-0.1831	-9.35	<.0001
PASI	-0.0025	0.0015	-0.0054	0.0004	-1.69	0.0906
HAQ × PASI	-0.0039	0.002	-0.0079	0	-1.94	0.0523

No. observations used: 386
No. clusters: 138

TABLE 47 Covariance matrix for utility regression

	Intercept	HAQ	PASI	HAQ × PASI
Intercept	0.0003295	-0.000292	-0.000014	0.0000126
HAQ	-0.000292	0.0006146	0.0000129	-0.000033
PASI	-0.000014	0.0000129	2.1946E-06	-0.000001607
HAQ × PASI	0.0000126	-0.000033	-0.000001607	4.0944E-06

The utility regression estimates are shown in *Table 46*, and the covariance matrix is shown in *Table 47*. It should be noted that in the ADEPT trial⁸⁸ a proportion of patients had a HAQ score of 0. It was therefore impossible for these patients to experience an improvement in their HAQ score. In order to ensure the utility regressions truly capture the impact a change in HAQ has on a patient's utility score, these patients have been excluded from the analysis.

Correlation between outcomes

There is no evidence presented to support the correlation across outcomes. How large are the correlations? What were the data restrictions that meant a trivariate analysis could not be completed? Can the data be presented?

Spearman correlations have been calculated using patient-level data from the ADEPT clinical trial.⁸⁸ There is a positive correlation between the two measures of the arthritis component of the disease (PsARC and ACR), indicating that a PsARC responder is also likely to be an ACR responder, although this correlation is not as strong as would be expected if these two measures were truly interchangeable (*Table 48*). As can be seen in *Table 49*, approximately 80% of PsARC responders were ACR 20 responders at week 12 in the treatment group in the ADEPT trial,⁸⁸ with a κ -coefficient of 0.56 (moderate agreement).

As can be seen in *Table 50* there is a significant and positive correlation between all three outcomes observed between week 12 and week 24. This is particularly high for ACR 20 response rates and is stronger in the adalimumab arm than in the placebo arm of the trial. It is anticipated that the lower correlation in the placebo arm is due to the fact that these patients may be classed as responders by chance rather than because they are actually responding to treatment. The probability that patients in the placebo arm who respond to treatment at week 12 are still responding to treatment at week 24 is therefore lower than for those patients in the adalimumab arm. Correlations are higher between ACR responses at week 12 and week 24 compared with PsARC response rates indicating that the ACR is a more robust measure of response than the PsARC.

TABLE 48 Spearman correlation between response measures of the arthritis component of the disease

PsARC	ACR ^b	Treatment ^a	
		Adalimumab (<i>n</i> =151)	Placebo (<i>n</i> =162)
PsARC (week 12)	ACR 20 (week 12)	0.57 (<i>p</i> <0.0001)	0.57 (<i>p</i> <0.0001)
PsARC (week 24)	ACR 20 (week 24)	0.64 (<i>p</i> <0.0001)	0.69 (<i>p</i> <0.0001)

a Correlation coefficient (significance).

b <20/20–50/50–70/70+.

TABLE 49 Kappa agreement correlation between ACR 20 and PsARC response in the adalimumab treatment group

Week 12 PsARC	Week 12 ACR 20	
	Non-responders: <i>n</i> (%)	Responders: <i>n</i> (%)
Non-responder	45 (77.5)	13 (22.4)
Responders	19 (20.4)	74 (79.5)
κ-coefficient	0.56 (moderate agreement)	

TABLE 50 Spearman correlation between outcomes over time

Weeks		Treatment ^a	
12	24	Adalimumab (<i>n</i> =151)	Placebo (<i>n</i> =162)
PsARC	PsARC	0.61 (<i>p</i> <0.0001)	0.37 (<i>p</i> <0.0001)
ACR ^b	ACR ^b	0.79 (<i>p</i> <0.0001)	0.33 (<i>p</i> <0.001)
		(<i>n</i> =69)	(<i>n</i> =69)
PASI ^c	PASI ^c	0.64 (<i>p</i> <0.0001)	0.39 (<i>p</i> <0.0001)

a Correlation coefficient (significance).

b <20/20–50/50–70/70+.

c <50/50–75/75–90/90+.

The correlations presented in *Table 51* indicate that there is a weak correlation between skin response and arthritis response. This suggests that patients who observe improvements in their skin symptoms may not observe similar improvements in their arthritis symptoms. *Table 52* indicates that approximately 62% of ACR 20 responders were also PASI 75 responders at week 12 in the ADEPT trial,⁸⁸ with a κ-coefficient of 0.31 (fair agreement). When interpreting these data it is important to remember that only a subset of patients in the ADEPT trial⁸⁸ were eligible for PASI assessment, thus reducing the statistical power of the analysis.

A trivariate analysis could not be completed for several reasons. First, in the ADEPT trial,⁸⁸ PASI was measured only in patients with a BSA ≥3%, meaning that PASI, PsARC and ACR response data were available only for 43.2% of patients (*n*=69). Excluding those patients with no PASI scores would have meant discarding most of the data on arthritis response, thus significantly reducing the power of the analysis. Including these patients would result in an error and the model would not be able to run due to the absence of PASI scores.

A further barrier to conducting a trivariate analysis was the computational burden required for such a complex analysis. For example, the model examining the relationship between ACR 20 at

TABLE 51 Spearman correlation between response criteria for the skin and arthritis components of the disease

Response measure		Treatment ^a	
Arthritis	Skin	Adalimumab (<i>n</i> =69)	Placebo (<i>n</i> =69)
PsARC (week 12)	PASI ^c (week 12)	0.49 (<i>p</i> <0.0001)	0.13 (<i>p</i> =0.2969)
PsARC (week 24)	PASI ^c (week 24)	0.36 (<i>p</i> =0.0023)	0.26 (<i>p</i> =0.304)
ACR ^b (week 12)	PASI ^c (week 12)	0.42 (<i>p</i> =0.0004)	0.23 (<i>p</i> =0.0614)
ACR ^b (week 24)	PASI ^c (week 24)	0.38 (<i>p</i> =0.0014)	0.23 (<i>p</i> =0.0612)

a Correlation coefficient (significance).

b <20/20–50/50–70/70+.

c <50/50–75/75–90/90+.

TABLE 52 Kappa agreement correlation for the skin and arthritis components in the adalimumab treatment group

Week 12 ACR 20 response	Week 12 PASI 75 response	
	Non-responders, <i>n</i> (%)	Responders, <i>n</i> (%)
Non-responder	19 (70.3)	8 (29.6)
Responders	16 (38)	26 (61.9)
κ-coefficient	0.31 (fair agreement)	

12 weeks and at 24 weeks took approximately 5 hours to compile; for the fixed-effects model it took a total of 50 hours to run three chains, while for random-effects models it took 500 hours. Expanding to a trivariate analysis would require many times this. It is therefore not possible to present the results of a trivariate analysis.

Schering-Plough¹⁵²

Regression of Quality of Life on Health Assessment Questionnaire and Psoriasis Area and Severity Index

- NICE request – 29 September 2009.

NICE requested a linear regression of QoL on the following covariates:

- Intercept
- HAQ
- PASI
- HAQ×PASI interaction term.

Two options are available for estimating the QoL data:

1. SF-36 to EQ-5D via Gray algorithm
2. EQ-5D.

The data source used here is the IMPACT 2 study^{82,90,91,95,98,106,112,116} (EXCEL files from Ewen Cummins' e-mails, 21 March 2009, Schering-Plough). EQ-5D was converted to a QoL index score using the published UK tariffs²¹² (Brazier algorithm).

Results

Patients with missing values for baseline EQ-5D, HAQ or PASI have been removed from both analyses. Multiple observations in the same patient were treated as independent observations, no cluster-based analysis was used. Sample size in both cases: $n = 740$ observations.

Using the Short Form questionnaire-36 items data via Gray algorithm

Covariate	Mean	Variance-covariance matrix			
		Intercept	HAQ	PASI	HAQ×PASI
Intercept	8.712e-01	5.978e-07	-4.215e-07	-3.698e-08	2.632e-08
HAQ	-2.490e-01	-4.215e-07	5.107e-07	2.679e-08	-3.024e-08
PASI	-2.485e-03	-3.698e-08	2.679e-08	9.536e-09	-6.684e-09
HAQ×PASI	5.928e-05	2.632e-08	-3.024e-08	-6.684e-09	6.405e-09

Using the European Quality of Life-5 Dimensions data

Covariate	Mean	Variance-covariance matrix			
		Intercept	HAQ	PASI	HAQ×PASI
Intercept	7.862e-01	9.233e-08	-6.510e-08	-5.712e-09	4.065e-09
HAQ	-1.437e-01	-6.510e-08	7.888e-08	4.139e-09	-4.670e-09
PASI	-2.648e-03	-5.712e-09	4.139e-09	1.437e-09	-1.032e-09
HAQ×PASI	9.927e-04	4.065e-09	-4.670e-09	-1.032e-09	9.893e-10

Appendix 7

Reviews of cost-effectiveness studies and checklists

Review of Olivieri *et al.*¹⁷⁸

- The PsA cost evaluation study: a cost-of-illness study on TNF inhibitors in patients with PsA with inadequate response to conventional therapy.¹⁷⁸

Overview

This is a before/after study that evaluated the costs and benefits of biologics (as a group) compared with no biologics. The study was undertaken in Italy and included 107 patients from nine tertiary referral centres. Both NHS and societal costs were included and HRQoL was measured using the EQ-5D. Results were expressed using a third-party payer and a societal perspective.

Summary of effectiveness data

The following outcomes were collected before and after biologics treatment: laboratory parameters, TJC/SJC, numbers of digits with dactylitis, Maastricht Ankylosing Spondylitis Enthesitis Score, Bath Ankylosing Spondylitis Disease Activity Index, Bath Ankylosing Spondylitis Functional Index, occiput to wall distance, chest expansion, modified Schober's test, visual analogue scale (VAS), duration of morning stiffness, PASI, HAQ, EQ-5D, SF-36, demographic characteristics, clinical characteristics, surgical procedures, use of health-care resources, days off work due to illness and caregiver time. Patients were interviewed using a structured electronic weeks report form. This was administered and completed by a physician. Resource use and HRQoL were collected for the 6 months preceding biologics treatment, at baseline, 6 months and 12 months following initiation of treatment.

Both the EQ-5D (VAS and utility) and the SF-36 were used to evaluate HRQoL. Only the EQ-5D utility scores were used in the cost-effectiveness analysis. The EQ-5D utilities were converted to QALYs by computing the difference between average per patient utility at enrolment (before biologics) and average utility after initiation of treatment. This difference was then multiplied by 0.5 (6 months).

At the end of the 12-month observation period there was a gain of 0.25 in utility, equating to a 0.12 gain in QALYs.

Summary of resource utilisation and cost data

As described above, resource use was retrospectively collected from patients, for the 6 months preceding biologics and for the 12-months after initiation of treatment. Resource use data collected were from surgical procedures, hospitalisations, visits to the physician, medications and other non-health-care items, including days off work, caregivers' time and transport to/from hospital visits. Case record forms were designed to collect all of this information from patients. This was administered and completed by physicians.

Medical costs were calculated by multiplying the items of resource use by the associated unit costs. The diagnosis-related group costs were used to represent the unit costs of hospitalisations. The authors did not state the sources for other medical costs. The costs of transportation were

taken directly from patients' reports. Carers' costs and days lost from work were costed using the human capital approach.

At the end of the 12-month follow-up, direct costs increased by €5052. There were some decreases in hospitalisation costs (€142) and indirect costs (costs to the patient and carers – €413).

Summary of cost-effectiveness

Incremental cost-effectiveness ratios were appropriately calculated using the differences in costs and QALYs described above.

The increase in costs is somewhat offset by the 0.12 increase in QALYs to produce an ICER of €40,876 for the NHS and an ICER of €37,591 for society.

The uncertainty regarding the estimates of costs and QALYs were expressed using cost-effectiveness acceptability curves (CEACs), showing the probability that biologic were cost-effective at various thresholds for a QALY gained. If a decision-makers' willingness-to-pay threshold was €45,000 then the probability that biologics is cost-effective is 0.82.

Comments

All TNFs were grouped together, although the majority of patients were taking etanercept. It is therefore not possible to estimate any differences in cost-effectiveness between the biologic drugs.

The analysis has a limited length of follow-up (6 months). PsA is a chronic disease and it is therefore likely that all differences in costs and outcomes between comparators can be captured in this short time frame.

Internal validity

This is a before/after study, so there may be a problem of confounding. It is possible that patients will get better over time as a result of increased monitoring as part of the study. It is not possible to disentangle these effects.

External validity

This is a relatively small sample of patients recruited from a single site. Patients, however, seem fairly typical of the PsA population in terms of disease markers.

Checklist for Olivieri *et al.*¹⁷⁸

✓ or ×

Study question	Grade	Comments
1. Costs and effects examined	✓	
2. Alternatives compared	×	
3. The viewpoint(s)/perspective of the analysis is clearly stated (e.g. NHS, society)	×	Two perspectives chosen; confusing statements about which is used for costing
Selection of alternatives		
4. All relevant alternatives are compared (including 'do nothing' if applicable)	×	
5. The alternatives being compared are clearly described (who did what, to whom, where and how often)	✓	
6. The rationale for choosing the alternative programmes or interventions compared is stated		

Form of evaluation

- | | |
|--|----|
| 7. The choice of form of economic evaluation is justified in relation to the questions addressed | × |
| 8. If a cost-minimisation design is chosen, have equivalent outcomes been adequately demonstrated? | NA |

Effectiveness data

- | | |
|---|----|
| 9. The source(s) of effectiveness estimates used are stated (e.g. single study, selection of studies, systematic review, expert opinion) | ✓ |
| 10. Effectiveness data from RCT or review of RCTs | × |
| 11. Potential biases identified (especially if data not from RCTs) | × |
| 12. Details of the method of synthesis or meta-analysis of estimates are given (if based on an overview of a number of effectiveness studies) | NA |

Costs

- | | |
|--|---|
| 13. All of the important and relevant resource use included | ✓ |
| 14. All of the important and relevant resource use measured accurately (with methodology) | ✓ |
| 15. Appropriate unit costs estimated (with methodology) | × |
| 16. Unit costs reported separately from resource use data | × |
| 17. Productivity costs treated separately from other costs | ✓ |
| 18. The year and country to which unit costs apply is stated with appropriate adjustments for inflation and/or currency conversion | × |

Benefit measurement and valuation

- | | |
|---|---|
| 19. The primary outcome measure(s) for the economic evaluation are clearly stated | ✓ |
| 20. Methods to value health states and other benefits are stated | ✓ |
| 21. Details of the individuals from whom valuations were obtained are given | ✓ |

Decision modelling

- | | |
|--|----|
| 22. Details of any decision model used are given (e.g. decision tree, Markov model) | NA |
| 23. The choice of model used and the key input parameters on which it is based are adequately detailed and justified | NA |
| 24. All model outputs described adequately | NA |

Discounting

- | | |
|--|----|
| 25. Discount rate used for both costs and benefits | NA |
| 26. Do discount rates accord with NHS guidance? | NA |

Allowance for uncertainty*Stochastic analysis of patient-level data*

- | | |
|--|---|
| 27. Details of statistical tests and CIs are given for stochastic data | ✓ |
| 28. Uncertainty around cost-effectiveness expressed (e.g. CI around ICER, CEACs) | ✓ |
| 29. Sensitivity analysis used to assess uncertainty in non-stochastic variables (e.g. unit costs, discount rates) and analytic decisions (e.g. methods to handle missing data) | ✓ |

Stochastic analysis of decision models

30. Are all appropriate input parameters included with uncertainty?	NA
31. Is second-order uncertainty (uncertainty in means) included rather than first order (uncertainty between patients)?	NA
32. Are the probability distributions adequately detailed and appropriate?	NA
33. Sensitivity analysis used to assess uncertainty in non-stochastic variables (e.g. unit costs, discount rates) and analytic decisions (e.g. methods to handle missing data)	NA

Deterministic analysis

34. The approach to sensitivity analysis is given (e.g. univariate, threshold analysis, etc.)	No deterministic sensitivity analysis performed
35. The choice of variables for sensitivity analysis is justified	
36. The ranges over which the variables are varied are stated	

Presentation of results

37. Incremental analysis is reported using appropriate decision rules	✓	
38. Major outcomes are presented in a disaggregated as well as aggregated form	✓	
39. Applicable to the NHS setting	×	Biologics not evaluated separately; problems with internal validity

NA, not available.

Review of Bansback *et al.*¹⁷⁶

- Estimating the cost and health status consequences of treatment with TNF antagonists in patients with PsA.¹⁷⁶

Overview

This paper aimed to generate estimates of the long-term benefits (in terms of HRQoL) of biologics (etanercept) in PsA. In addition, they assessed the cost-effectiveness of biologics compared with conventional therapies. The model is based on that used in the Wyeth submission¹⁵³ to the previous NICE appraisal of biologic drugs.⁷³ The Health Assessment Questionnaire Disability Index (HAQ-DI) was used to measure benefit and linked to utilities to generate QALYs. A third-party payer perspective was used for the analysis.

An individual sampling model was used to simulate costs and benefits over a 10-year time horizon, using data from a variety of sources, including RCTs, open-label and observational data. The authors do not state which software was used to programme the model.

Following failure on conventional DMARDs, sequencing of three comparators was evaluated. Etanercept was compared with combination therapy on MTX and ciclosporin or leflunomide.

Summary of effectiveness data

To estimate the initial (3-month) effect of etanercept, patient-level data from a phase III randomised trial was obtained (Mease *et al.*⁵²). HAQ was measured at 4, 12 and 24 weeks, after which patients were invited to join an open-label extension of the trial and be treated with etanercept. The randomised data was used within a multivariate regression model to predict

3-month HAQ change. The open-label extension data was used to estimate HAQ progression beyond 3 months.

A cohort study containing moderate-to-severe patients with PsA from the Academic Unit of Musculoskeletal Disease at the University of Leeds²⁰¹ was used to estimate health-state utilities. The relationship between health utilities and HAQ was examined by fitting linear regression models that were estimated by generalised estimating equation algorithms.

The data set was also used to estimate long-term progression on best standard care and to explore the effect of adding the skin component (PASI) to the prediction of health utilities. The effect of PASI was found to be very small and not statistically significant. This may have been due to the relatively homogeneous PASI scores in the Leeds data set.²⁰¹

Withdrawal from etanercept was taken from the literature and assigned values of 34%²¹³ and 42%²¹⁴ for psoriatic arthritis and rheumatoid arthritis respectively. Patients that withdrew from treatment were assumed to worsen instantaneously by the same magnitude as they initially improved. This assumption is based on the 'rebound' effect observed in a previous economic evaluation of etanercept in RA.

Discounted 10-year QALYs were 4.49 for etanercept, 3.67 for ciclosporin and 3.84 for leflunomide.

Summary of resource utilisation and cost data

Costs included all direct costs attributable to patients with PsA, including drug costs, monitoring, administration and hospitalisation costs. The cost offsets of improving disability were also estimated using a study of patients with RA.

Total costs of etanercept over 10 years is estimated as £51,122, ciclosporin £28,010 and leflunomide £26,822.

Summary of cost-effectiveness

An individual sampling model was used to estimate costs and benefits over 10 years. Baseline characteristics were sampled from the demographics from the Mease 2004 trial.²⁰⁰ The model tracks the decision to continue treatment at 3-monthly intervals. At each interval a decision about whether to continue treatment was randomly sampled. Biologics were assumed to halt the progression of disease while treatment is continued.

One-way and probabilistic sensitivity analysis were used to explore uncertainties in the data and the model structure.

The results show that at 6 months etanercept gives an additional 0.4 QALYs at an additional cost of £3000, which gives an ICER of around £70,000. At 10 years, the QALY benefit increased giving and ICER of £28,000 compared with ciclosporin and £38,000 compared with leflunomide.

Sensitivity analysis showed that the ICER was sensitive to the baseline HAQ and annual HAQ progression. The probabilistic sensitivity analysis showed the decision to recommend etanercept as the optimum treatment was uncertain at 10 years, with a probability that is it cost-effective of 0.58 (at a threshold of £30,000 per QALY).

Comments

This is a good-quality evaluation of biologics for PsA. However, only the biologic etanercept was evaluated and therefore the study cannot inform the question as to which biologic is most

cost-effective (adalimumab, infliximab and etanercept). It only addresses the question of if biologics are cost-effective compared with ciclosporin and leflunomide. In addition, only data from a single phase II trial was used to determine effectiveness. More trials are now available and this evidence should be appropriately synthesised.

The skin component of PsA was not included. The effect of PASI was explored using the Leeds data set²⁰¹ and found not to be statistically significant. However, this may have been due to the relatively homogeneous PASI scores in the Leeds data set.²⁰¹ Alternative data sets to explore the effect on PASI should have been explored.

Only a single scenario (rebound to gain) was used to represent the uncertainty regarding the effect of withdrawal from treatment on HAQ. Other scenarios, such as rebound to NH were not explored.

Internal validity

There are no major issues with internal validity.

External validity

The use of a single trial to estimate the initial response to treatment may be expected to produce less robust estimates and limit generalisability. In addition, the study is of little use in determining the relative cost-effectiveness of alternative biologics, as the use of biologics was limited to etanercept. This is a major limitation to the study's generalisability.

Checklist for Bansback et al.¹⁷⁶

✓ or ×		
Study question	Grade	Comments
1. Costs and effects examined	✓	
2. Alternatives compared	×	Only looks at the biologic etanercept
3. The viewpoint(s)/perspective of the analysis is clearly stated (e.g. NHS, society)	✓	
Selection of alternatives		
4. All relevant alternatives are compared (including 'do nothing' if applicable)	×	A 'do-nothing' (palliative care) option is not considered
5. The alternatives being compared are clearly described (who did what, to whom, where and how often)	✓	
6. The rationale for choosing the alternative programmes or interventions compared is stated	✓	
Form of evaluation		
7. The choice of form of economic evaluation is justified in relation to the questions addressed	✓	
8. If a cost-minimisation design is chosen, have equivalent outcomes been adequately demonstrated?	NA	
Effectiveness data		
9. The source(s) of effectiveness estimates used are stated (e.g. single study, selection of studies, systematic review, expert opinion)	✓	But limited to a single study
10. Effectiveness data from RCT or review of RCTs	✓	
11. Potential biases identified (especially if data not from RCTs)	×	Fact that the skin component not considered is not discussed
12. Details of the method of synthesis or meta-analysis of estimates are given (if based on an overview of a number of effectiveness studies)	NA	

Costs

- | | |
|--|---|
| 13. All of the important and relevant resource use included | ✓ |
| 14. All of the important and relevant resource use measured accurately (with methodology) | ✓ |
| 15. Appropriate unit costs estimated (with methodology) | ✓ |
| 16. Unit costs reported separately from resource use data | × |
| 17. Productivity costs treated separately from other costs | × |
| 18. The year and country to which unit costs apply is stated with appropriate adjustments for inflation and/or currency conversion | ✓ |

Benefit measurement and valuation

- | | |
|---|---|
| 19. The primary outcome measure(s) for the economic evaluation are clearly stated | ✓ |
| 20. Methods to value health states and other benefits are stated | ✓ |
| 21. Details of the individuals from whom valuations were obtained are given | ✓ |

But only limited information presented

Decision modelling

- | | |
|--|---|
| 22. Details of any decision model used are given (e.g. decision tree, Markov model) | ✓ |
| 23. The choice of model used and the key input parameters on which it is based are adequately detailed and justified | × |
| 24. All model outputs described adequately. | ✓ |

Not clear why it was appropriate to use an individual sampling model

Discounting

- | | |
|--|---|
| 25. Discount rate used for both costs and benefits | ✓ |
| 26. Do discount rates accord with NHS guidance? | ✓ |

Also explored in the sensitivity analysis

Allowance for uncertainty*Stochastic analysis of patient-level data*

- | | |
|--|----|
| 27. Details of statistical tests and CIs are given for stochastic data | NA |
| 28. Uncertainty around cost-effectiveness expressed (e.g. CI around incremental cost-effectiveness ratio (ICER), CEACs) | NA |
| 29. Sensitivity analysis used to assess uncertainty in non-stochastic variables (e.g. unit costs, discount rates) and analytic decisions (e.g. methods to handle missing data) | NA |

Stochastic analysis of decision models

- | | |
|--|---|
| 30. Are all appropriate input parameters included with uncertainty? | × |
| 31. Is second-order uncertainty (uncertainty in means) included rather than first order (uncertainty between patients)? | |
| 32. Are the probability distributions adequately detailed and appropriate? | ✓ |
| 33. Sensitivity analysis used to assess uncertainty in non-stochastic variables (e.g. unit costs, discount rates) and analytic decisions (e.g. methods to handle missing data) | ✓ |

Costs presented as fixed

Both are presented

Deterministic analysis

- | | |
|---|---|
| 34. The approach to sensitivity analysis is given (e.g. univariate, threshold analysis, etc.) | ✓ |
| 35. The choice of variables for sensitivity analysis is justified | ✓ |
| 36. The ranges over which the variables are varied are stated | ✓ |

Presentation of results

37. Incremental analysis is reported using appropriate decision rules	×	Compares etanercept with all other comparators not just against next-best strategy
38. Major outcomes are presented in a disaggregated as well as aggregated form	✓	
39. Applicable to the NHS setting	×	Use of a single trial to determine effectiveness potentially limits generalisability

NA, not available.

Review of Bravo Vergel *et al.*¹⁷⁷

- The cost-effectiveness of etanercept and infliximab for the treatment of patients with PsA.¹⁷⁷

Overview

The aim of the study was to estimate the cost-effectiveness of etanercept and infliximab for the treatment of active and progressive PsA in patients who have inadequate response to standard treatment (palliative care), including DMARD therapy. The analysis is based on the York Assessment Group model developed as part of the previous NICE appraisal of biologic therapies for PsA.⁷³ A probabilistic cohort model was developed in EXCEL and used over 10- and 40-year time horizons. A third-party payer perspective was used for the analysis.

Summary of effectiveness data

Short-term trial data^{57,78,81} was used to model the response of patients (measured by PsARC criteria) to biologics. A Bayesian evidence synthesis was used to link the trials via indirect comparisons methods. A WINBUGS synthesis model was also used to estimate the mean improvements in HAQ score conditional on response. The placebo effect was deducted from the estimates of effect as the comparison strategy was palliative care ('do nothing'). The mean HAQ change for non-responders was also estimated by the synthesis model and incorporated into the decision model for the initial 3-month period.

The absolute change in HAQ conditional on response from the Mease *et al.*^{52,78} and IMPACT trials⁸¹ was obtained from the pharmaceutical companies. HAQ progression for palliative-care patients was taken from the Leeds cohort study.²⁰¹

The posterior distributions estimated by the synthesis model were used to populate the decision model. In addition the probability of withdrawals from treatment was taken from Geborek *et al.*¹⁹⁸ Standard UK mortality rates were used and no excess mortality risk for patients with PsA was assumed.

Utility data was taken from a previous cost-effectiveness analysis for biologics in PsA¹⁷⁶ in which the relationship between health-state utility and the HAQ-DI was examined by fitting a regression model to the Leeds data set.²⁰¹

The results show that infliximab is the most effective strategy in both scenarios (4.636 and 4.455 QALYs for rebound to gain and rebound to NH, respectively) and etanercept the next most effective (4.514 and 4.356 for both scenarios). Palliative care is the least effective strategy.

Summary of resource utilisation and cost data

Drug costs (including acquisition, administration and monitoring) were inputted into the model as fixed costs. Drug costs were taken from the BNF.⁶⁵ The issue of vial sharing for infliximab was

explored as a sensitivity analysis. Administration and monitoring costs were estimated using industry assumptions regarding resources use and published unit costs.

The costs associated with PsA were estimated as a function of HAQ score using a published study in RA. These costs were assumed to include the costs of palliative care.

The results show that total mean costs were highest for infliximab in both rebound scenarios (£64,274 and £64,418 for rebound to gain and rebound to NH respectively). Etanercept is the next most costly (£44,111 and £44,169 for both scenarios) and palliative care the least costly (£10,718 and £10,679 for both scenarios).

Summary of cost-effectiveness

A modified decision tree was used to model the cohort of patients with PsA over time. The model was run separately for males and females.

Patients have a probability of responding to biologics in an initial 3-month period. This response is measured using the PsARC criteria. The associated HAQ change for responders is then estimated, this accounts for the progressive nature of the disease. For responders there is an annual risk of withdrawal (for any reason) from treatment. Once patients have withdrawn from treatment they experience a worsening in HAQ.

Uncertainty regarding parameters was characterised using the posterior distributions from the evidence synthesis and by assigning probability to other parameters. Monte Carlo simulation was used to generate lifetime costs and QALYs for the three strategies. Scenario analysis was used to explore some of the other uncertainties in the model, such as the rebound for patients withdrawing from treatment (rebound equal to gain and rebound equal to NH), time horizon, discount rate and number of vials of infliximab.

The ICERs for infliximab are unlikely to be considered reasonable at £165,363 and £205,345 compared to etanercept for rebound to gain and rebound to NH, respectively. The ICER for etanercept may or may not be acceptable depending on the threshold for cost-effectiveness and the scenario for rebound believed to be correct. The ICER for rebound equal to gain is £26,361 and the ICER for rebound equal to NH is £30,628. Both of these ICERs are compared to palliative care.

Etanercept has the highest probability of being cost effective in the rebound equal to gain scenario (0.693 at a £30,000 threshold), whereas palliative care has the highest probability of being cost-effective in the rebound equal to NH scenario (0.554 at a £30,000 threshold).

Comments

This is a good quality evaluation of biologics for PsA. Its limitations are not considering the use of the biologics adalimumab, simply presenting the uncertainty about the rebound effect as scenarios and exclusion of the skin component.

Internal validity

There are no major issues with internal validity.

External validity

The psoriasis component (measured using PASI) was not included in the model. HRQoL for patients with PsA is influenced by both the arthritis component and the psoriasis component. Failure to capture the effect of treatments on the psoriasis component of disease represents a major limitation of the study.

In addition, the uncertainty regarding the effect of withdrawal from treatment on HAQ was only presented as two alternative scenarios. It is therefore difficult to determine the value of further research to reduce this uncertainty.

Checklist for Bravo Vergel¹⁷⁷

✓ or ×		
Study question	Grade	Comments
1. Costs and effects examined	✓	
2. Alternatives compared	✓	
3. The viewpoint(s)/perspective of the analysis is clearly stated (e.g. NHS, society)	✓	
Selection of alternatives		
4. All relevant alternatives are compared (including 'do nothing' if applicable)	✓	
5. The alternatives being compared are clearly described (who did what, to whom, where and how often)	✓	
6. The rationale for choosing the alternative programmes or interventions compared is stated	×	Does not justify why a 'do-nothing' strategy is more appropriate than an active comparator such as other DMARDs
Form of evaluation		
7. The choice of form of economic evaluation is justified in relation to the questions addressed	✓	
8. If a cost-minimisation design is chosen, have equivalent outcomes been adequately demonstrated?	NA	
Effectiveness data		
9. The source(s) of effectiveness estimates used are stated (e.g. single study, selection of studies, systematic review, expert opinion)	✓	
10. Effectiveness data from RCT or review of RCTs	✓	
11. Potential biases identified (especially if data not from RCTs)	×	Comparability of studies not discussed; fact that the skin component not considered is not discussed
12. Details of the method of synthesis or meta-analysis of estimates are given (if based on an overview of a number of effectiveness studies)	✓	
Costs		
13. All of the important and relevant resource use included	✓	
14. All of the important and relevant resource use measured accurately (with methodology)	✓	
15. Appropriate unit costs estimated (with methodology)	✓	
16. Unit costs reported separately from resource use data	×	Although further details available in HTA report
17. Productivity costs treated separately from other costs	×	Not considered
18. The year and country to which unit costs apply is stated with appropriate adjustments for inflation and/or currency conversion	✓	
Benefit measurement and valuation		
19. The primary outcome measure(s) for the economic evaluation are clearly stated	✓	QALYs
20. Methods to value health states and other benefits are stated	✓	Fact that the skin component not considered is not discussed
21. Details of the individuals from whom valuations were obtained are given	×	Does reference a separate publication

Decision modelling

22. Details of any decision model used are given (e.g. decision tree, Markov model) ✓
23. The choice of model used and the key input parameters on which it is based are adequately detailed and justified ✓
24. All model outputs described adequately ✓

Discounting

25. Discount rate used for both costs and benefits ✓
26. Do discount rates accord with NHS guidance? ✓

Allowance for uncertainty*Stochastic analysis of patient-level data*

27. Details of statistical tests and CIs are given for stochastic data NA
28. Uncertainty around cost-effectiveness expressed (e.g. CI around ICER, CEACs) NA
29. Sensitivity analysis used to assess uncertainty in non-stochastic variables (e.g. unit costs, discount rates) and analytic decisions (e.g. methods to handle missing data) NA

Stochastic analysis of decision models

30. Are all appropriate input parameters included with uncertainty? × Costs presented as fixed
31. Is second-order uncertainty (uncertainty in means) included rather than first order (uncertainty between patients)? ✓
32. Are the probability distributions adequately detailed and appropriate? ✓
33. Sensitivity analysis used to assess uncertainty in non-stochastic variables (e.g. unit costs, discount rates) and analytic decisions (e.g. methods to handle missing data) ✓

Deterministic analysis

34. The approach to sensitivity analysis is given (e.g. univariate, threshold analysis, etc.) ✓
35. The choice of variables for sensitivity analysis is justified ✓
36. The ranges over which the variables are varied are stated ✓

Presentation of results

37. Incremental analysis is reported using appropriate decision rules ✓
38. Major outcomes are presented in a disaggregated as well as aggregated form ✓
39. Applicable to the NHS setting ✓

NA, not available.

Review of Abbott submission¹⁵¹

An individual sampling model is used to assess the cost-effectiveness of adalimumab compared with etanercept, infliximab and conventional DMARDs. Third-, fourth- and fifth-line treatments are modelled with fourth- and fifth-line treatments always comprising DMARDs. The patients included in the model were assumed to have not responded to at least two DMARDs,

individually or in combination. A third-party payer perspective was used for the analysis. The model is programmed in 'R' and a lifetime time horizon is assumed.

Summary of effectiveness data

Baseline patient characteristics from the ADEPT trial⁸⁸ were used to determine the baseline distribution of patients characteristics in the model.

Long-term outcomes were expressed as QALYs. To generate QALYs, short- and long-term outcomes were estimated. These longer-term outcomes were then regressed on to utilities. Short-term efficacy was determined using PsARC, ACR and PASI responses. Longer-term outcomes were HAQ and PASI.

In the base-case model, 12-week PsARC response rates were used to determine continuation of therapy beyond the trial period. A mixed-treatment fixed-effects meta-analysis was used to determine response rates. The evidence synthesis was undertaken using WINBUGS, and utilised data from 10 different source studies,^{51,52,62,78,81,82,88,83,154,155} each of which compares different treatment, some of which that are not included in this appraisal. Three Bayesian bivariate analyses were conducted to determine: (1) joint distribution of 12-week PsARC and ACR response rates; (2) 24-week PsARC response conditional on the 12-week PsARC response; and (3) 24-week ACR response conditional on the 12-week ACR response. The joint distribution of 12- and 24-week PASI response rate is modelled independently. The associated WINBUGS code was presented. In a sensitivity analysis, continuation beyond 12 weeks was estimated directly from the BSRBR and so PsARC response rates were not used to determine continuation.

Patient-level data from the ADEPT⁸⁸ study were then used to estimate HAQ and PASI changes dependent on the magnitude of response. Patients who had previously failed two or more DMARDs and had a baseline HAQ > 0 were included in the analysis. A forward stepwise regression analysis was used to select significant variables in predicting HAQ and PASI improvement, including ACR response type, HAQ at baseline, demographics, disease duration and treatment. In order to estimate the PASI, the data were transformed by $\log(\text{PASI} + 0.5)$. The authors state that this was done 'to obtain normality'. It is important to note that this log-transformation assumes that a 1% improvement in PASI will lead to a constant change in utility, regardless of the absolute change in PASI. For example, this regression assumes that a reduction in PASI score from 16 to 0 leads to the same change in HRQoL as a reduction in PASI score from 8 to 0. A linear regression on the other hand assumes that a reduction in PASI by 16 points gives twice the HRQoL benefit of a reduction in PASI by 8 points, regardless of the baseline. A similar regression was specified for HAQ at 24 weeks.

Placebo response rates from trials were used to represent the DMARD efficacy data. A common efficacy was used for all DMARDs. A reduction multiplier was applied to response rates for subsequent DMARDs (24% reduction in receiving response). Alternative reduction multipliers were examined in sensitivity analysis.

Long-term progression of HAQ while on biologics was assumed to be 0.0005 per year. This was taken from a longitudinal analysis of the Bath Psoriatic Arthritis Database (reference not given). Progression on DMARDs was 0.024 per year. Progression of patients who do not respond (defined as ACR 20) is assumed to be 0.06 per year. These were both estimated using the Leeds data set.²⁰¹ PASI is assumed to halt for responders.

The model assumes that patients withdrawn from therapy at 12 months due to inefficacy reflect the PsARC response rates in practice. Rates of withdrawal from therapy between 1 and 3 years,

due to either adverse events or loss of efficacy, were estimated using data from the BSRBR registry¹⁶² and specified using a Weibull distribution. No differences between drugs were assumed due to selection bias. Sensitivity analysis explored differential biologics withdrawal and the use of data from Kristensen *et al.*²¹⁵ Withdrawal rates for conventional DMARDs were taken from a smaller study by Malesci *et al.*¹⁹⁹ and were again specified using a Weibull distribution. It is unclear how the parameters for either of these Weibull distributions were derived from the referenced data. Following withdrawal from treatment patients HAQ is assumed to rebound equivalent to the initial gain and PASI rebound to the starting level. The rate of HAQ progression following stopping biologics therapy was assumed to be the same as for patients who do not respond to therapy (0.066).

Two sources of data were used to estimate the improvement in health utility through a direct linear relationship with HAQ and PASI. Base case uses the ADEPT trial⁸⁸ of adalimumab. SF-36 was converted to EQ-5D. In a sensitivity analysis, data from the Bath Psoriatic Arthritis Database was used. Functions for health utilities reported with and without skin effect. Any interaction between HAQ and PASI was not explored.

The model used PsA specific mortality inflators²⁹ along with UK life tables.

Infliximab was associated with the highest QALYs (8.49), followed by etanercept and adalimumab (8.33) and then DMARDs (7.47).

Summary of resource utilisation and cost data

The costs of all drugs were estimated using MIMS (online and print prescribing database for health professionals)²¹⁶ as opposed to the *BNF*.⁶⁵ Infliximab costs were calculated assuming that four vials were used per infusion based on an average patient weight of 80 kg.

Resource use associated with monitoring and administering drugs was estimated according to BSR guidelines. Assumes infliximab requires a half-day hospital visit for each infusion. A single outpatient visit is required for adalimumab and etanercept. Gives references for each unit cost used to cost these items of resource use.

The relationship between HAQ score and disease-related hospital costs was estimated using the NOAR database. A physician survey was conducted to assess the ongoing costs of psoriasis, therefore estimating the relationship between PASI. This was done for four hypothetical patients with differing PASI scores. The median responses on resource utilisation were to generate costs. A logarithmic regression was then fitted to the data points to estimate cost based on a continuous PASI scale.

The base-case results show that infliximab is the most costly strategy (£104,772).

Summary of cost-effectiveness

An individual sampling model is used to simulate the disease progression of a cohort of patients with PsA over a lifetime horizon. The model is written in 'R' with an accompanying evidence synthesis model written in WINBUGS.

Initial response to treatment is determined according to the PsARC criteria at the end of the initial 3-month period. Patients who do not respond according to PsARC take the next available treatment in the sequence. Patients who respond according to PsARC criteria remain on treatment unless they withdraw due to either loss of efficacy or toxicity. Three-monthly cycles are used.

It is assumed that patients who do not receive an biologics agent after failure of two conventional DMARDs would continue treatment with an alternative conventional DMARD.

The ICER for infliximab is unlikely to be considered acceptable given current levels for the threshold (ICER = £199,596 compared with adalimumab). Etanercept is dominated by adalimumab. Adalimumab has an ICER of £29,827 compared with a DMARD.

Probabilistic sensitivity analysis was conducted and shows that there is considerable uncertainty regarding the optimum strategy. Adalimumab had a probability of < 0.5 of being cost-effective at thresholds up to £30,000. This rose to around 0.7 at thresholds of > £60,000.

Multiple univariate sensitivity analysis were conducted to assess the models sensitivity to effectiveness parameters, withdrawal rates, disease progression estimates, utilities, costs, rebound effect, characteristics of patients and discounting. Results were sensitive to many of the changes in parameters, in particular the stopping rule for BSRBR withdrawal rates and the rebound assumption. The impact on decision uncertainty using alternative parameter assumptions was not presented.

Comments

This is a comprehensive evaluation of biologics for the treatment of PsA. There are, however, a number of limitations. In particular, the model assumes that after failing biologics, patients will receive another DMARD, or combinations of DMARDs. This is un-realistic as patients have previously failed two or more DMARDs. Placebo response rates from trials were also used to represent the DMARD efficacy data. This means that DMARDs will have no effect but will incur costs, biasing against DMARDs. The authors do not give a clear rationale for not choosing palliative care as the comparator to biologics.

Withdrawals were calculated using data from a single data set. There are other potential registry data sets available, which could have been synthesised with the data by Saad *et al.*¹⁶² In addition, parameters for a Weibull distribution were derived using longitudinal data from three time points and the data were assumed to be independent. This assumption is incorrect, because the same patients contribute data to the probability of survival at 2 years as 1 year. Only one scenario was used to determine HAQ following rebound – that patients will rebound equivalent to the initial gain.

Internal validity

There are no major issues with internal validity.

The model results have been checked and verified by the assessment team. There are some issues with the cost estimates used in the model. These cannot be ratified with the costs presented in the report. In particular the drug, monitoring and administration costs in the model differ from those presented in the report.

External validity

The use of DMARDs as a comparator to biologics is a major limitation. As discussed, DMARDs are unlikely to be considered for patients withdrawing from biologic treatment, as this cohort of patients will have previously failed two or more DMARDs.

In addition, the evidence synthesis uses all available evidence to generate estimates of effect, using data from 10 different sources. However, some of these data sources relate to treatments not included as comparators in the model, such as golimumab. It is not clear if the relative treatment effects can be transferred from one biologic to another.

Checklist for Abbott submission¹⁵¹

✓ or ×		
Study question	Grade	Comments
1. Costs and effects examined	✓	
2. Alternatives compared		
3. The viewpoint(s)/perspective of the analysis is clearly stated (e.g. NHS, society)	✓	
Selection of alternatives		
4. All relevant alternatives are compared (including 'do nothing' if applicable)	×	Biologics compared with DMARDs and no palliative care
5. The alternatives being compared are clearly described (who did what, to whom, where and how often)	×	Does not describe what the series of DMARDs are
6. The rationale for choosing the alternative programmes or interventions compared is stated	✓	
Form of evaluation		
7. The choice of form of economic evaluation is justified in relation to the questions addressed	✓	
8. If a cost-minimisation design is chosen, have equivalent outcomes been adequately demonstrated?	NA	
Effectiveness data		
9. The source(s) of effectiveness estimates used are stated (e.g. single study, selection of studies, systematic review, expert opinion)	✓	
10. Effectiveness data from RCT or review of RCTs	✓	
11. Potential biases identified (especially if data not from RCTs)	×	Limitations of using registry data not discussed
12. Details of the method of synthesis or meta-analysis of estimates are given (if based on an overview of a number of effectiveness studies)	✓	Evidence synthesis model is not well annotated and thus is difficult to interpret
Costs		
13. All of the important and relevant resource use included	✓	
14. All of the important and relevant resource use measured accurately (with methodology)	✓	
15. Appropriate unit costs estimated (with methodology)	✓	
16. Unit costs reported separately from resource use data	✓	
17. Productivity costs treated separately from other costs	NA	
18. The year and country to which unit costs apply is stated with appropriate adjustments for inflation and/or currency conversion	×	
Benefit measurement and valuation		
19. The primary outcome measure(s) for the economic evaluation are clearly stated	✓	
20. Methods to value health states and other benefits are stated	✓	
21. Details of the individuals from whom valuations were obtained are given	✓	
Decision modelling		
22. Details of any decision model used are given (e.g. decision tree, Markov model)	✓	
23. The choice of model used and the key input parameters on which it is based are adequately detailed and justified	✓	Do not give adequate justification for why an individual sampling model is used

24. All model outputs described adequately	×	Calculation of withdrawal rates is not clear
Discounting		
25. Discount rate used for both costs and benefits	✓	
26. Do discount rates accord with NHS guidance?	✓	
Allowance for uncertainty		
<i>Stochastic analysis of patient-level data</i>		
27. Details of statistical tests and CIs are given for stochastic data	✓	
28. Uncertainty around cost-effectiveness expressed (e.g. CI around ICER, CEACs)	✓	
29. Sensitivity analysis used to assess uncertainty in non-stochastic variables (e.g. unit costs, discount rates) and analytic decisions (e.g. methods to handle missing data)	✓	
Stochastic analysis of decision models		
30. Are all appropriate input parameters included with uncertainty?	✓	Costs are fixed
31. Is second-order uncertainty (uncertainty in means) included rather than first order (uncertainty between patients)?	✓	Both
32. Are the probability distributions adequately detailed and appropriate?	✓	
33. Sensitivity analysis used to assess uncertainty in non-stochastic variables (e.g. unit costs, discount rates) and analytic decisions (e.g. methods to handle missing data)	✓	
Deterministic analysis		
34. The approach to sensitivity analysis is given (e.g. univariate, threshold analysis, etc.)	✓	
35. The choice of variables for sensitivity analysis is justified	✓	
36. The ranges over which the variables are varied are stated	✓	
Presentation of results		
37. Incremental analysis is reported using appropriate decision rules	✓	
38. Major outcomes are presented in a disaggregated as well as aggregated form	✓	
39. Applicable to the NHS setting	✓	

NA, not available.

Review of Schering-Plough submission¹⁵²

A cohort model was developed to assess the cost-effectiveness of four treatment alternatives: adalimumab, etanercept, infliximab and DMARDs (assumed to represent palliative care) for patients with PsA. Sequential use of biologics was not considered. The report states that a sequence of DMARDs was considered.

The model was programmed in EXCEL with evidence synthesis undertaken in WINBUGS. A third-party payer perspective was used for the analysis.

Summary of effectiveness data

The primary outcome was QALYs, estimated using both HAQ and PASI. An evidence synthesis model was used to determine the response to biologics and the associated HAQ and PASI change for responders. The evidence synthesis model used to generate initial HAQ and PASI changes and the data used are presented. In many cases results from the York model were used as priors. Data from the previous York model¹⁷⁷ along with IMPACT,⁸¹ IMPACT 2,⁸² Mease *et al.*,^{52,78} GO-REVEAL,¹⁵⁶ Genovese *et al.*⁸³ and ADEPT⁵¹ were used in the evidence synthesis model. As change in absolute PASI was modelled, absolute changes in PASI were inferred from relative changes reported in trials. It is also assumed that the average HAQ change in non-responders can be used when data are not reported by responders/non-responders. From this HAQ for responders can be inferred from the aggregate data.

At the end of the first cycle (12 weeks), patients were categorised as responders or not responders according to their PsARC response. Responders continued with treatment, whereas non-responders discontinued treatment and instead received palliative care. The results of the evidence synthesis showed that PASI was not different in individuals with and without a PsARC response. This was concluded using data for golimumab, but assumed for all drugs. All patients start with the same PASI score. PASI change is not assumed to be correlated with baseline score.

The same HAQ and PASI change is assumed for the two 12-week cycles for responders. In addition, a HAQ reduction is also assumed for the third cycle (CiC information has been removed). The HAQ reductions for the second and third cycles are taken from the GO-REVEAL trial¹⁵⁶ (this is a trial of golimumab that is not included in the appraisal; however, relationships observed in this trial were assumed across all biologics). For non-responders the HAQ and PASI change is only applied for the first cycle. The placebo effect is then subtracted from the treatment effect (on HAQ) estimated by the evidence synthesis model; however, palliative care in this model is DMARDs (active treatment). This will not bias the comparison between biologic, but may affect the comparison with palliative care.

HAQ is not assumed to progress for patients responding to treatment and is not correlated with initial HAQ change. A sensitivity analysis is conducted assuming that progression for responders is the same as NH. Patients on palliative care (in this case actually DMARDs) will progress in line with NH (0.0719 annual). This is estimated from the Leeds study.²⁰¹ The distribution placed on this assumes that the value can only be non-negative. The NH of PASI was assumed to be flat, based on expert opinion (source for this is not stated). Following rebound patients rebounding are assumed to return to their original PASI score.

Two alternative methods to generate utilities were explored: the Gray algorithm¹⁸⁰ (selected as the base case) and the Brazier algorithm.¹⁸¹ The Gray algorithm¹⁸⁰ converts SF-36 to EQ-5D then EQ-5D to utilities, whereas the Brazier algorithm¹⁸¹ estimates utilities directly from SF-36. Explanatory variables used in the model were: HAQ, PASI, HAQ² and PASI². Interaction between PASI and HAQ was not explored. The GO-REVEAL data was used to estimate the regression.

Annual withdrawals from treatment were taken from the Geborek *et al.* study¹⁹⁸ and are 11.4% per annum. The same withdrawal rate was applied to all strategies. After withdrawal patients will go onto palliative care. Patients also have an annual risk of death. PsA specific mortality multipliers are also included.²⁹

The results show that palliative care is the strategy associated with the lowest QALYs in all base-case scenarios (5.79 to 6.68 depending on the group of patents). Infliximab is the most

effective strategy for all base-case scenarios, for all patients as a group and psoriasis patients (8.65 QALYs for all patients and 8.40 QALYs for patients with psoriasis). For patients without psoriasis etanercept is the most effective (9.14 QALYs).

Summary of resource utilisation and cost data

Resource use associated with treatment, administration and monitoring was taken from the previous York model. Costs associated with adalimumab were assumed to be the same as etanercept. The *BNF*⁶⁵ was used to cost medications. Costs for infliximab were calculated using 60-, 70- and 80-kg weights for patients, in addition to the use of four and three and a half vials.

Ongoing costs as a function of HAQ were derived from the Kobelt *et al.* study.⁴¹ Patients on treatment incur only 85% of these costs, whereas those withdrawing from treatment incur 100%. (CiC information has been removed.)

The base-case results for all patients produce a total cost of £64,704 for palliative care, £99,278 for adalimumab, £108,481 for etanercept, and between £107,954 and £123,475 for infliximab, depending on the weight of patients. Similar patterns were observed separately for patients with minimal psoriasis and patients with psoriasis.

Summary of cost-effectiveness

An initial two cycles of 12 weeks were modelled followed by annual cycles. Half-cycle correction is applied. In the first cycle, patient's response to PsARC is assessed and his/her associated HAQ and PASI change is determined. PsARC responders on continue with current treatment, whereas those do not respond will move on to palliative care. PsARC responders will then experience an annual risk of withdrawal from treatment with an associated HAQ loss. Two scenarios were modelled for the rebound: rebound equal to gain (followed by NH after 3 months) and rebound equal to NH.

For approximately one-third of patients with no clinically significant psoriasis component to their disease (estimated from the IMPACT^{79–81,89,96,109,111,113–115,117,118} and IMPACT 2^{82,90,91,95,98,106,112,116} trials) only the change in HAQ is modelled. The PASI impact on QoL is not included for these patients. Costs and QALYs are reported separately for psoriatic and non-psoriatic patients as well as the group as a whole.

The base-case results are presented for 60-, 70- and 80-kg patients and for patients with psoriasis, minimal psoriasis and all patients. For a 60-kg patient, infliximab is the most cost-effective strategy for all patients, and for psoriatic patients, dominating etanercept and extendedly dominating adalimumab. For a 70-kg patient, etanercept is the most cost-effective strategy for all patients and for psoriatic patients, with an ICER of £12,696 compared with adalimumab (however, this is extendedly dominated so should be compared with palliative care, which gives an ICER over £16K) for psoriatic patients and £12,606 for all patients. For an 80-kg patient, etanercept is again the most cost-effective strategy for all patients and for psoriatic patients, with ICERs of £12,696 and £12,606, respectively, compared with adalimumab. For all patient weights, etanercept is the most cost-effective with an ICER of £12,432 compared with adalimumab for non-psoriatic patients.

A number of univariate sensitivity analyses were conducted: reduction in the baseline HAQ, HAQ reduction beyond week 12, non-zero HAQ progression for responders after week 12, reduction in the baseline PASI score, 20-year time horizon as opposed to lifetime, exclusion

of phototherapy costs, reduction in annual withdrawals from 11.4% to 5.7%, reduction of NH progression to 0.036 annually and using the Brazier algorithm to calculate utilities. Vial optimisation is not considered in the sensitivity analysis.

Results for the sensitivity analysis are presented as ICERs versus palliative care and ICERs versus other biologics. It is not clear from the results if these results are for psoriatic, non-psoriatic or all patients. The results of the sensitivity analysis appear sensible given the changes in parameter assumptions made, for example, increasing the lifetime of the model makes all biologics more cost-effective.

Biologics appear to be robust to the sensitivity analysis compared with palliative care, apart from changing the algorithm for estimating QoL. This generated ICERs of >£36,000 for all biologics compared with palliative care. For patients with a body weight of <70 kg, infliximab remained the most cost-effective strategy compared with other biologics, apart from when the baseline HAQ is reduced from 1.14 to 0.90, no HAQ change beyond first cycle is assumed, and HAQ of responders to etanercept, infliximab and adalimumab progress at the same rate as NH after initial HAQ improvement.

Probabilistic sensitivity analysis is also conducted. This shows a great deal of decision uncertainty for the optimum strategies given each of the base-case assumptions.

Comments

This is a good quality evaluation of the relevant biologics for the treatment of PsA. There are, however, a number of issues that are of concern. In particular, the use of data from a trial of golimumab to inform a number of model parameters, the use of DMARDs to represent the comparator, the addition of HAQ gains beyond the initial cycle, and the use of a single data source to estimate withdrawals.

Internal validity

There are no major issues with internal validity.

We were able to replicate the deterministic results. The probabilistic results could not be replicated; however, differences were small and the interpretation of results was the same in terms of ordering of strategies.

External validity

Data from a number of sources were used to estimate benefits of treatments. However, data (CiC information has been removed) from a trial of golimumab was also used to inform a number of parameters, in particular HAQ and PASI changes. This biologic was not included in the model and it is unclear if the relationships observed in this trial can be assumed to transfer across to other biologics. In addition, the estimated placebo effect has been subtracted from the treatment effect (on HAQ); however, palliative care in this model is actually DMARDs (active treatment). This will not bias the comparison between biologics, but may affect the comparison with palliative care.

Withdrawals were also estimated from a single data source, and it was unclear if this is a representative data source. It is of concern that identification of studies to generate withdrawal rates was not more systematic.

Checklist for Schering-Plough submission¹⁵²

✓ or ×		
Study question	Grade	Comments
1. Costs and effects examined	✓	
2. Alternatives compared	✓	
3. The viewpoint(s)/perspective of the analysis is clearly stated (e.g. NHS, society)	✓	
Selection of alternatives		
4. All relevant alternatives are compared (including 'do nothing' if applicable)	✓	
5. The alternatives being compared are clearly described (who did what, to whom, where and how often)	✓	
6. The rationale for choosing the alternative programmes or interventions compared is stated	✓	
Form of evaluation		
7. The choice of form of economic evaluation is justified in relation to the questions addressed	✓	
8. If a cost-minimisation design is chosen, have equivalent outcomes been adequately demonstrated?	NA	
Effectiveness data		
9. The source(s) of effectiveness estimates used are stated (e.g. single study, selection of studies, systematic review, expert opinion)	✓	
10. Effectiveness data from RCT or review of RCTs	✓	
11. Potential biases identified (especially if data not from RCTs)	×	Potential biases of using registry/survey data not discussed
12. Details of the method of synthesis or meta-analysis of estimates are given (if based on an overview of a number of effectiveness studies)	✓	WINBUGS code presented
Costs		
13. All of the important and relevant resource use included	✓	
14. All of the important and relevant resource use measured accurately (with methodology)	✓	
15. Appropriate unit costs estimated (with methodology)	✓	
16. Unit costs reported separately from resource use data	✓	
17. Productivity costs treated separately from other costs	✓	
18. The year and country to which unit costs apply is stated with appropriate adjustments for inflation and/or currency conversion	✓	
Benefit measurement and valuation		
19. The primary outcome measure(s) for the economic evaluation are clearly stated	✓	
20. Methods to value health states and other benefits are stated	✓	
21. Details of the individuals from whom valuations were obtained are given	✓	
Decision modelling		
22. Details of any decision model used are given (e.g. decision tree, Markov model)	✓	
23. The choice of model used and the key input parameters on which it is based are adequately detailed and justified	✓	
24. All model outputs described adequately	✓	Not clear why PASI was predicted for PsARC responders and non-responders

Discounting

- | | |
|--|---|
| 25. Discount rate used for both costs and benefits | ✓ |
| 26. Do discount rates accord with NHS guidance? | ✓ |

Allowance for uncertainty*Stochastic analysis of patient-level data*

- | | |
|--|----|
| 27. Details of statistical tests and CIs are given for stochastic data | NA |
| 28. Uncertainty around cost-effectiveness expressed (e.g. CI around ICER, CEACs) | NA |
| 29. Sensitivity analysis used to assess uncertainty in non-stochastic variables (e.g. unit costs, discount rates) and analytic decisions (e.g. methods to handle missing data) | NA |

Stochastic analysis of decision models

- | | |
|--|---|
| 30. Are all appropriate input parameters included with uncertainty? | ✓ |
| 31. Is second-order uncertainty (uncertainty in means) included rather than first order (uncertainty between patients)? | ✓ |
| 32. Are the probability distributions adequately detailed and appropriate? | ✓ |
| 33. Sensitivity analysis used to assess uncertainty in non-stochastic variables (e.g. unit costs, discount rates) and analytic decisions (e.g. methods to handle missing data) | ✓ |

Deterministic analysis

- | | |
|---|---|
| 34. The approach to sensitivity analysis is given (e.g. univariate, threshold analysis, etc.) | ✓ |
| 35. The choice of variables for sensitivity analysis is justified | ✓ |
| 36. The ranges over which the variables are varied are stated | ✓ |

Presentation of results

- | | |
|--|---|
| 37. Incremental analysis is reported using appropriate decision rules | ✓ |
| 38. Major outcomes are presented in a disaggregated as well as aggregated form | ✓ |
| 39. Applicable to the NHS setting | ✓ |

NA, not available.

Review of Wyeth submission¹⁵³

An individual patient-based model (discrete event simulation) was developed to assess the cost-effectiveness of etanercept in comparison with infliximab, adalimumab, ciclosporin and best supportive care (BSC) for the treatment of chronic patients with PsA in the UK. Sequences were not considered; instead, patients are given BSC after treatment failure.

In addition to the primary analysis using the patient-level data, subgroups were also defined in the sensitivity analysis. These were mild, moderate and severe HAQ, and mild, severe and very severe PASI.

The model was programmed in EXCEL and the evidence synthesis in WINBUGS. The model used a 50-year time horizon and a third-party payer perspective. Subgroups at baseline were defined in terms of mild, moderate and severe HAQ, and mild, moderate and severe PASI.

Summary of effectiveness data

Baseline characteristics of patients were taken from the Mease *et al.* trial.⁵² Characteristics at baseline were age, gender, disease duration, HAQ, eligibility for PASI assessment, PASI score, polyarthritis, and concurrent use of MTX. In total, 37.6% of patients in the trial were not eligible for PASI assessment, and were assigned a PASI score of 0.

The benefit of treatments was measured using QALYs. These were estimated using PsARC response and changes in HAQ and PASI. Data from the published MTC for adalimumab¹⁷⁹ and the Mease *et al.* trial⁵² comparing etanercept with placebo were used to estimate effects. The results from the MTC excluding the data from the open-label study were used as the base case. The inclusion of this study in the MTC was examined in sensitivity analysis. The benefits of ciclosporin are assumed to be equivalent to that of placebo and the data taken from the MTC. PsARC response used to model initial withdrawal from treatment at 12 and 24 weeks. Non-responders according to PASI are assumed not to withdraw.

Response rate at 4 weeks (from Mease *et al.*⁵²) applied together with the 12- and 24-week rates from the MTC for adalimumab.¹⁷⁹ Regressions were used to find the relationship between response rates at 12 and 4 weeks (results presented). The initial improvement in PASI 75 (week 4, 12 and 24) was estimated using multivariate regression models and the relationship between patient characteristics.

Response rates by subgroup population were not available from the MTC. Instead response rates, subgrouped according to baseline severity of HAQ or PASI, for etanercept were obtained from the Mease *et al.* trial.⁵² The ratio of etanercept response rates from the MTC¹⁷⁹ compared with the etanercept subgroup response rates from Mease *et al.*⁵² were then used in conjunction with the treatment specific response rates from the MTC to estimate subgroup response rates for each of the treatments modelled.

Initial change in HAQ (4, 12 and 24 weeks) was modelled using changes in PASI and PsARC (again from Mease *et al.*⁵² and adalimumab STA¹⁷⁹). The same magnitude of change is assumed for all three biologics agents.

Longer-term changes in HAQ were modelled using observed changes in PASI score, PASI 75 response and PsARC response. Changes in PASI are predicted and the results used together with PsARC response to predict changes in HAQ. Results from the regressions are presented.

It is assumed that patients who remain and respond to biologics experience a lack of progression on HAQ. Annual HAQ progression of 0.028 is used for ciclosporin (Sokoll, no reference given). The annual HAQ progression rate (mean = 0.07) for patients on BSC was obtained from the Leeds data set.²⁰¹

Longer-term withdrawals (made up on adverse events and loss of efficacy) according to HAQ, were estimated using data from Saad *et al.*¹⁶² (using the BSRBR registry). A Weibull function was fitted to etanercept data at 1, 2 and 3 years. HRs between infliximab and ETN, and adalimumab and ETN were used to derive survivor functions for infliximab and adalimumab. Ciclosporin is given an annual withdrawal of 34% and assumes patients withdraw exponentially. The effect of withdrawing from treatment is assumed to be either equal to gain or back up to NH.

The relationship between HAQ and EQ-5D observed in the PRESTA data set was used in the base case to generate utilities. The relationship between PASI and EQ-5D was not included, as PASI is already included as a predictor of HAQ. PRESTA is a 24-week clinical study comparing two forms of etanercept. A linear mixed-effect model was used to explore the relationship. Regression results are reported. Other data sets are used in the sensitivity analysis (including the Leeds study used in the original York model²⁰¹).

Patients have an annual risk of death, taken from UK life tables. PsA specific mortality multipliers are also included.²⁹

The base-case results show that etanercept was associated with the highest gain in QALYs (6.90) followed by adalimumab (6.54), infliximab (6.39) and then ciclosporin (5.96).

Summary of resource utilisation and cost data

The costs of medication were taken from the *BNF*.⁶⁵ A weight of 70 kg was assumed for infliximab and vial sharing was used. Administration and monitoring was costed as recommended in the BSR guidelines. Etanercept and adalimumab were assumed to be self-administered and thus received zero cost for baseline apart from one outpatient visit at baseline. Infliximab had a half-day care hospital cost assigned for each infusion.

Health-care costs associated with PsA were taken from an evaluation by the Health Outcomes Data Repository (HODaR) using data from BSRBR and The Health Improvement Network (THIN). The THIN database does not include HAQ, thus variables in the BSRBR data set, which were also available in the THIN data, were used to predict HAQ values for the THIN data. Regression results from THIN are reported. Ongoing costs associated with PASI are not included as PASI is assumed to be a predictor of HAQ.

The costs of BSC are assumed to be included in the health-care costs associated the PsA. A sensitivity analysis was conducted to test this assumption.

The base-case results show that ciclosporin was associated with the lowest cost (£53,860). Infliximab had the highest total costs (£66,867).

Summary of cost-effectiveness

An initial two cycles of 12 weeks were modelled followed by annual cycles. Half-cycle correction is applied. Costs and QALYs were discounted by 3.5%.

The base-case results show that infliximab is dominated by adalimumab, and adalimumab is extendedly dominated by etanercept. Comparing etanercept to ciclosporin results in an ICER of £12,480.

A number of univariate sensitivity analyses were conducted: HAQ progression rates, rebound of HAQ on withdrawal from treatment, utility functions, discount rates, monitoring cost for BSC, using results from the MTC, including an open-label study of adalimumab at 24 weeks, withdrawal rates from treatment and subgroups by baseline severity of PsA and PASI. Results are sensitive to the rebound effect, the utility function used and the annual progression on standard care. The results appear to make sense in terms of the changes made to parameters assumptions. For example, increasing the rate of HAQ progressing while receiving biologics increases costs slightly and decreases QALYs for adalimumab, etanercept and infliximab.

Probabilistic sensitivity analysis is also conducted (using 2000 iterations) to generate distributions of total costs and QALYs. This shows a great deal of decision uncertainty for the optimum

strategies given each of the base-case assumptions. Probabilistic sensitivity analysis shows there is a 0.65 probability that etanercept will be cost-effective at a threshold of £20,000.

Comments

This is a good-quality evaluation of biologics for the treatment of PsA. There are, however, a number of issues that may cause concern. In particular, the initial change in HAQ and longer-term changes in HAQ were determined including PASI as an explanatory variable. Although PASI and HAQ are used to measure the severity of the two components of PsA, psoriasis and arthritis, there is no clear clinical rationale to suggest that a patient's psoriasis should affect their degree of functional disability or joint disease, as measured by HAQ. In addition, the same magnitude of initial HAQ change is assumed for all three biologic agents.

Another limitation of the model is the use of ciclosporin as a comparator to biologics as opposed to palliative care; however, the benefits of are assumed to be equivalent to that of placebo. Thus, although the drugs cost are incurred for ciclosporin, no additional benefit beyond that of palliative care is used. This could be expected to bias against ciclosporin.

In addition, withdrawals were calculated using data from a single data set¹⁶² and assuming that data from three time points were independent and could be used to derive parameters for a Weibull distribution. The assumption of independence is unlikely to be valid (see *Appendix 12*). Withdrawal rates could potentially have a large impact on the results, as patients are essentially either in the on treatment or off treatment states, and so it is of concern that identification of studies to generate withdrawal rates was not more systematic.

Internal validity

There are no major issues with internal validity.

It was not possible to replicate the deterministic model results as there was a runtime error in the visual basic macro. Given this, and the anticipated 24 hour + simulation time, we did not attempt to replicate the results of the probabilistic model.

External validity

Data from an existing MTC for adalimumab¹⁷⁹ and the Mease *et al.* trial⁵² were used to estimate effects. Although data were included from a number of trials in the adalimumab MTC, the original review used to identify trials to populate this MTC was restricted to a review of clinical trials including adalimumab as an intervention.

As discussed above, the use of ciclosporin as a comparator to biologics as opposed to palliative care is unlikely to be appropriate, given that the patients relevant for treatment with biologics will have failed at least two previous DMARDs.

Checklist for Wyeth submission¹⁵³

✓ or ×		
Study question	Grade	Comments
1. Costs and effects examined	✓	
2. Alternatives compared	✓	
3. The viewpoint(s)/perspective of the analysis is clearly stated (e.g. NHS, society)	✓	

Selection of alternatives

- | | | |
|---|---|--|
| 4. All relevant alternatives are compared (including 'do nothing' if applicable) | × | Ciclosporin used as comparator not palliative care |
| 5. The alternatives being compared are clearly described (who did what, to whom, where and how often) | ✓ | |
| 6. The rationale for choosing the alternative programmes or interventions compared is stated | ✓ | |

Form of evaluation

- | | | |
|--|----|--|
| 7. The choice of form of economic evaluation is justified in relation to the questions addressed | ✓ | |
| 8. If a cost-minimisation design is chosen, have equivalent outcomes been adequately demonstrated? | NA | |

Effectiveness data

- | | | |
|---|---|---|
| 9. The source(s) of effectiveness estimates used are stated (e.g. single study, selection of studies, systematic review, expert opinion) | ✓ | |
| 10. Effectiveness data from RCT or review of RCTs | ✓ | |
| 11. Potential biases identified (especially if data not from RCTs) | × | Does not discuss the bias associated with using registry and survey data. |
| 12. Details of the method of synthesis or meta-analysis of estimates are given (if based on an overview of a number of effectiveness studies) | ✓ | |

Costs

- | | | |
|--|----|--|
| 13. All of the important and relevant resource use included | × | Does not include the costs of PASI, as these are used to predict HAQ |
| 14. All of the important and relevant resource use measured accurately (with methodology) | ✓ | |
| 15. Appropriate unit costs estimated (with methodology) | ✓ | Unclear how the costs of HAQ have been used in the model |
| 16. Unit costs reported separately from resource use data | ✓ | |
| 17. Productivity costs treated separately from other costs | NA | |
| 18. The year and country to which unit costs apply is stated with appropriate adjustments for inflation and/or currency conversion | ✓ | |

Benefit measurement and valuation

- | | | |
|---|---|--------------------------------------|
| 19. The primary outcome measure(s) for the economic evaluation are clearly stated | ✓ | PASI incorrectly used to predict HAQ |
| 20. Methods to value health states and other benefits are stated | ✓ | |
| 21. Details of the individuals from whom valuations were obtained are given | ✓ | |

Decision modelling

- | | | |
|--|---|---|
| 22. Details of any decision model used are given (e.g. decision tree, Markov model) | × | The need to use an individual sampling model was not justified sufficiently |
| 23. The choice of model used and the key input parameters on which it is based are adequately detailed and justified | ✓ | |
| 24. All model outputs described adequately | ✓ | |

Discounting

- | | | |
|--|---|--|
| 25. Discount rate used for both costs and benefits | ✓ | |
| 26. Do discount rates accord with NHS guidance? | ✓ | |

Allowance for uncertainty*Stochastic analysis of patient-level data*

- | | |
|--|---|
| 27. Details of statistical tests and CIs are given for stochastic data | ✓ |
| 28. Uncertainty around cost-effectiveness expressed (e.g. CI around ICER, CEACs) | ✓ |
| 29. Sensitivity analysis used to assess uncertainty in non-stochastic variables (e.g. unit costs, discount rates) and analytic decisions (e.g. methods to handle missing data) | ✓ |

Stochastic analysis of decision models

- | | | |
|--|---|--|
| 30. Are all appropriate input parameters included with uncertainty? | ✓ | |
| 31. Is second-order uncertainty (uncertainty in means) included rather than first order (uncertainty between patients)? | ✓ | |
| 32. Are the probability distributions adequately detailed and appropriate? | × | Not clear how the uncertainty in HAQ costs is propagated |
| 33. Sensitivity analysis used to assess uncertainty in non-stochastic variables (e.g. unit costs, discount rates) and analytic decisions (e.g. methods to handle missing data) | ✓ | |

Deterministic analysis

- | | |
|---|---|
| 34. The approach to sensitivity analysis is given (e.g. univariate, threshold analysis, etc.) | ✓ |
| 35. The choice of variables for sensitivity analysis is justified | ✓ |
| 36. The ranges over which the variables are varied are stated | ✓ |

Presentation of results

- | | |
|--|---|
| 37. Incremental analysis is reported using appropriate decision rules | ✓ |
| 38. Major outcomes are presented in a disaggregated as well as aggregated form | ✓ |
| 39. Applicable to the NHS setting | ✓ |

NA, not available.

Appendix 8

Critique of the manufacturers' models

Choice of comparator(s)

The submission by Schering-Plough¹⁵² compares etanercept, infliximab and adalimumab with palliative care. Wyeth¹⁵³ and Abbott¹⁵¹ use DMARDs as the comparator to the biologics. Wyeth¹⁵³ specifies ciclosporin as the DMARD. Patients who fail on biologics or ciclosporin then receive BSC, presumed the same as palliative care. Abbott¹⁵¹ uses a series of unspecified DMARDs as comparators with fourth- and fifth-line treatments always being DMARDs. Although Wyeth¹⁵³ and Abbott¹⁵¹ compare biologics to DMARDs, they assign effectiveness estimates from the placebo arms of trials. Therefore, the effectiveness of biologics is likely to be artificially inflated.

Patient characteristics

The Schering-Plough model¹⁵² uses a homogeneous cohort of patients that was considered to be representative of the groups of patients eligible for biologic therapies to treat PsA, i.e. patients who have failed two or more conventional DMARDs.

Wyeth¹⁵³ and Abbott¹⁵¹ however, model heterogeneous cohorts using individual patient simulation. Both of the individual sampling models are difficult to critique and require a significant time to run probabilistic sensitivity analysis. In the Wyeth model¹⁵³ patients' characteristics are taken from the Mease *et al.*⁵² trial comparing etanercept and placebo. Characteristics at baseline were age, gender, disease duration, HAQ, eligibility for PASI assessment, PASI score, polyarthritis and concurrent use of MTX. As 37.6% of patients in the trial were not eligible for PASI assessment, these patients were assigned a PASI score of 0. In the Abbott submission, baseline patient characteristics from the ADEPT trial⁸⁸ were used to determine the baseline distribution of patients characteristics in the model. The ADEPT trial⁸⁸ compared adalimumab with placebo. Only patients who had failed at least two DMARDs were included in the analysis. Patients' characteristics that were included were age, disease duration, gender, presence of psoriasis, percentage on MTX, PASI and HAQ score.

Adjustment for placebo effect

A placebo adjustment accounts for any overestimate of the *absolute* response rates in both placebo and treatment groups, compared with what would be expected in general practice.

There may be a need to adjust for the placebo effect observed in the clinical trials if the placebo effects in the trials are assumed not to occur in usual practice (see *Appendix 9*).

The Wyeth¹⁵³ and Abbott¹⁵¹ models do not make an adjustment for placebo response. Both assume the comparator group represents the effect of DMARD. However, for both of these models the effects observed in the placebo arms of trials are used to represent the effectiveness of DMARDs. In other words, these models assume that DMARDs are no more effective than placebo in these patients.

In the Schering-Plough model,¹⁵² the placebo effect is subtracted from the treatment effect (on HAQ) for responders and non-responders on biologics, estimated by the evidence synthesis model. However, palliative care in this model is DMARDs (active treatment). As an inactive treatment is not actually included in any of these three models, the use of a placebo adjustment should have little impact on the results or their interpretation. It will also not bias the comparison between biologics, but may overstate the effectiveness of biologics.

Sequencing

None of the four models considers the use of sequential biologics in the base-case scenario. The Abbott model¹⁵¹ uses a series of unspecified DMARDs, following failure of treatment with any biologic (up to fifth line), but the use of subsequent DMARDs for patients who have previously failed two or more DMARDs is unlikely in practice. A reduction multiplier is applied to response rates for subsequent DMARDs (24% reduction in receiving response in the base case). This reduction is justified using estimates from the BSRBR of the percentage of patients that withdraw on their second biologic at year 1 compared with the first course. A reference for these figures is not given.

The sequential use of biologics is likely to be feasible in practice; however, a lack of data on the effectiveness of biologics beyond first line limits the possibilities to consider such an analysis.

Outcomes of the evidence synthesis

Each of the three industry models uses an evidence synthesis component (implemented in WINBUGS) to generate estimates of treatment effect (see *Chapter 3, Assessment of effectiveness*). The Wyeth study¹⁵³ uses the evidence synthesis from a previous STA of adalimumab¹⁷⁹ and does not develop a de novo synthesis for this appraisal. The need for an evidence synthesis component is primarily because of the lack of head-to-head data from trials for the three biologics, thus there is a need to use a MTC model. Each model, however, generates different parameters using different data.

The model by Wyeth¹⁵³ generates estimates of PsARC and PASI 75 at 12 and 24 weeks using data from the published MTC for adalimumab¹⁷⁹ and the Mease *et al.* trial.⁵² A regression was undertaken to predict 4-week PsARC (from Mease *et al.*⁵²) from 12-week PsARC. Response rate at 4 weeks is applied, together with the 12- and 24-week rates, from the MTC for adalimumab.¹⁷⁹ The initial improvement in PASI 75 (weeks 4, 12 and 24) was estimated using multivariate regression models and the relationship between patient characteristics.

Schering-Plough¹⁵² estimates PsARC at 12 weeks for responders and non-responders. In the subgroup with > 3% body skin area PASI change from baseline at 12 weeks by PsARC response/no response was estimated. The prediction of PASI change by PsARC response is somewhat questionable. Schering-Plough¹⁵² also determine HAQ change at 12 weeks by PsARC response/no response and treatment drug was also estimated. In many cases the results from the previous York model were used as priors. The Abbott study¹⁵¹ used a mixed-treatment fixed-effects meta-analysis to determine: (1) joint distribution of 12-week PsARC and ACR response rates; (2) 24-week PsARC response conditional on the 12-week PsARC response; and (3) 24-week ACR response conditional on the 12-week ACR response. The joint distribution of 12- and 24-week PASI response rate is modelled independently. The results of the bivariate meta-analysis to determine the joint distribution of PsARC and ACR responses appears to differ from the estimates of the marginal probabilities of these two outcomes, shown in *Tables 22 and 24*. In these

tables, infliximab is most effective, followed by etanercept, then adalimumab. In the bivariate meta-analysis (Table 3.4.3.1.1 of the Abbott submission¹⁵¹), Abbott¹⁵¹ find that adalimumab is more effective than etanercept for PsARC and ACR responses. The reason for this discrepancy is not clear.

Decision to withdraw depending on initial response(s)

All of the industry models assume that patients are withdrawn from treatment if they are PsARC non-responders at 12 weeks, irrespective of PASI response. In addition, the Wyeth model¹⁵³ also allows patients to be withdrawn from treatment if they are non-responders at 24 weeks. Abbott¹⁵¹ conduct a sensitivity analysis in which continuation beyond 12 weeks is estimated directly from the BSRBR,¹⁶² and so PsARC response rates are not used to determine continuation. None of the industry models considers the possibility of different scenarios for discontinuation, for example, the possibility that there may be a response on either PsARC or PASI or both.

Initial change in Health Assessment Questionnaire for responders and non-responders

Schering-Plough¹⁵² predicts HAQ by PsARC response and treatment from the evidence synthesis. The latest available end points for HAQ were used to reflect short-term benefits. The same HAQ change is assumed for the two initial 12-week cycles for responders. In addition, a HAQ reduction is also assumed for the third cycle (-0.0313). The HAQ reductions for the second and third cycles are taken from (CiC information has been removed). For non-responders, the HAQ change is only applied for the first cycle, after which a NH progression is assumed.

The Abbott study¹⁵¹ predicts HAQ at 12 and 24 weeks as a function of ACR response (20, 50, etc.), baseline HAQ, age, gender, baseline PsA duration, concomitant MTX and if receiving biologic drugs (ADEPT⁸⁸). HAQ does not differ by biologic drug.

The Wyeth study¹⁵³ estimates the initial change in HAQ (4, 12 and 24 weeks) using changes in PASI, baseline HAQ and PsARC (from Mease *et al.*⁵² and adalimumab STA¹⁷⁹). The same magnitude of change is assumed for all three biologic agents. Despite the justification given in the report for using PASI to predict HAQ, the use of the skin component of PsA to predict the arthritis component of the disease is of doubtful validity. There is no evidence to suggest that one component of the disease is a good predictor of the other: patients can have differing degrees of both components and those with severe arthritis will not necessary have severe psoriasis and vice versa.

Health Assessment Questionnaire progression while responding on a biologic therapy

As in the earlier York Assessment Group model, Wyeth¹⁵³ and Schering-Plough¹⁵² assume that HAQ does not progress for patients who are responding to a biologic therapy. The Schering-Plough model¹⁵² incorporates a slight improvement in HAQ over the first year. The Abbott model¹⁵¹ assumes that HAQ will worsen by 0.0005 per year. This figure was taken from a longitudinal analysis of the Bath Psoriatic Arthritis Database (reference not given).

The Abbott model¹⁵¹ also models a subgroup of patients where ACR < 20 separately and uses a HAQ progression rate of 0.066 per year from the Leeds cohort.²⁰¹

Health Assessment Questionnaire progression when on disease-modifying antirheumatic drugs

In the Schering-Plough model¹⁵² the comparator is palliative care, and thus progression is assumed to be that of NH (0.066 per year).²⁰¹ For the Abbott¹⁵¹ and Wyeth¹⁵³ models, DMARDs are used as comparators. Abbott¹⁵¹ uses an annual rate of progression of 0.024 from the Leeds cohort study.²⁰¹ Wyeth¹⁵³ uses a similar rate of 0.028 from Sokoll (reference not given).

Health Assessment Questionnaire progression while not on biologic therapy

All of the industry models use the Leeds cohort study²⁰¹ data to estimate HAQ progression while not on biologic therapy (also called NH progression). The Abbott study¹⁵¹ estimates this as a 0.066 increase in HAQ per year, Wyeth¹⁵³ an 0.069 increase and Schering-Plough¹⁵² an 0.071 increase per year. It is not clear why the same data source appears to generate three slightly different estimates, but these differences are unlikely to have major impacts on the cost-effectiveness results.

The Leeds data set is small, including only 24 patients. In addition, patients surveyed do not meet the requirements for this analysis in that many have not failed at least two previous DMARDs. It is also not clear if patients met the current guideline criteria for initiating biologics for PsA (three tender and three swollen joints).

Initial change in psoriasis severity while on biologic therapy

Each of the models uses a different approach to estimate the initial change in psoriasis severity after treatment with a biologic. The Wyeth study¹⁵³ generates the initial improvement in PASI 75 (weeks 4, 12 and 24) using multiple regression models and the relationship between patient characteristics. Schering-Plough¹⁵² estimates the PASI change from baseline to 12 weeks for PsARC responders/non-responders in their evidence synthesis model. As change in absolute PASI was modelled, absolute changes in PASI were inferred from relative changes reported in trials. It is not clear why PASI change was estimated for PsARC responders and non-responders, and not for PASI responders. Abbott¹⁵¹ predict the initial (12-week) change in PASI, using baseline PASI and proportion who are PASI 50/75/90 responders. Abbott¹⁵¹ also predicts this at 24 weeks.

Correlation between Psoriasis Area and Severity Index and Psoriatic Arthritis Response Criteria responses

Biologics are intended to treat both joint disease and psoriasis. Clinical response at 3 months is measured using the PsARC for joints and PASI 75 for skin conditions for these two aspects, respectively. The PsARC and PASI 75 responses are not necessarily independent (see *Appendix 10*).

Each of the industry models uses a different approach to account for any correlation between PASI and PsARC responses. The Wyeth model¹⁵³ assumes that PASI is a predictor of HAQ (see *Appendix 8* for further detail), which is unlikely. Abbott¹⁵¹ assumes that they are independent and thus models them separately (see *Appendix 8* for further detail). The Schering-Plough model¹⁵²

predicts PASI by PsARC response, thus generating a different PASI change for PsARC responders and non-responders, by drug.

Psoriasis progression on and off biologic therapy

Each of the models assumes that psoriasis will not progress on or off treatment, i.e. psoriasis will not worsen over time. This assumption is justified quoting clinical opinion, although this is not referenced.

Health Assessment Questionnaire rebound after discontinuation of biologic therapy

Following withdrawal from treatment, either due to adverse events or loss of efficacy, it can be expected that there will be some change in patients' HAQ scores. The previous York model¹⁷⁷ looked at two possible scenarios for this: rebound by the same amount as initial gain and rebound back to NH progression (see *Appendix 11*). The models from Wyeth¹⁵³ and Schering-Plough¹⁵² also explore these two scenarios. The ICERs for all biologics increase significantly. The Abbott model¹⁵¹ uses only the rebound to initial gain scenario, as it states that rebound to NH is unlikely to be possible as halting joint destruction does have an impact on long-term disability.

Psoriasis rebound when stopping therapy

Each of the industry models assume that following withdrawal from treatment, patients PASI score will rebound by the original gain. As PASI is not assumed to progress while receiving treatment, the rebound will be to the original PASI score. Clinical opinion is cited as the source of this evidence, but no reference is given.

Withdrawal rates

To estimate the probability of withdrawal while receiving biologics, due to either loss of efficacy or adverse events, Schering-Plough¹⁵² uses the same rates as used in the previous York model (0.11 per year from Geborek *et al.*¹⁹⁸ beyond the initial 12-week period) for biologics. As the comparator is palliative care (in active treatment) no withdrawals were seen in the comparator arm.

Wyeth¹⁵³ and Abbott¹⁵¹ use evidence from a recent paper by Saad *et al.*,¹⁹¹ which used data from the BSBDR registry to estimate parameters of a Weibull distribution in order to quantify the rate of withdrawal over time. This is used to represent a common withdrawal probability for all biologics. On seeking clarification from Wyeth,¹⁵³ they confirmed that a Weibull curve was fitted to the proportion of patients on etanercept at 1, 2 and 3 years. Calibrating the two parameters of the Weibull function was undertaken in order to minimise the error between the observed and predicted proportion of patients still treated with etanercept. The root mean square error between the observed and predicted proportion was 0.01961. On seeking clarification from Abbott¹⁵¹ they confirmed that the reported figures in Table 2 of Saad *et al.*¹⁹¹ These are slightly lower than the values fitted in the Wyeth analysis.¹⁵³ A diagram showing observed versus predicted survival was presented. (CiC information has been removed.) No further details of this study were presented.

There are a number of issues with the Wyeth¹⁵³ and Abbott¹⁵¹ approach. First, no justification was given for the choice of Weibull distributions rather than other parametric distributions. It may be that other distributions offered a better fit. Second, the 1-year rates from the BSRBR are likely to

include non-responders to biologics in addition to those who withdraw due to loss of efficacy or adverse events after the initial 3-month period. As these initial withdrawals are already counted as non-responders, there is a degree of double counting. Third, this approach assumes that the data points are independent, which is unlikely.

Utility estimates

Each of the industry models uses different methodologies and data sets to link changes in HAQ and PASI to utilities, in order to generate QALYs (*Table 53*).

The Wyeth model¹⁵³ uses the relationship between HAQ and EQ-5D, observed in the PRESTA data set (a clinical of etanercept including 752 patients),¹⁵⁷ to generate utilities. The relationship between PASI and EQ-5D was not included, as PASI is already included as a predictor of HAQ in the Wyeth model.¹⁵³ PRESTA is a 24-week clinical study comparing two forms of etanercept. A linear mixed-effect model was used to explore the relationship. The use of other data sets is explored in sensitivity analysis, including the Leeds study and the Mease *et al.* data.⁵² The ICER of etanercept compared with ciclosporin was £12,666 (using the function from Leeds), and £15,795 (using the function from patients receiving adalimumab) compared with £31,828 when using the function from Mease *et al.*

The Schering-Plough¹⁵² model explores two alternative methods to generate utilities: the Gray algorithm¹⁸⁰ and the Brazier algorithm.¹⁸¹ The Gray algorithm¹⁸⁰ converts SF-36 profiles to EQ-5D profiles, and then EQ-5D profiles to utilities. The Brazier algorithm¹⁸¹ estimates utilities directly from SF-36. The Gray algorithm¹⁸⁰ was used in the base-case analysis. The GO-REVEAL¹⁵⁶ trial data were used in a multiple regression model using HAQ, PASI, HAQ² and PASI², with no interaction terms, as explanatory variables. The Abbott model¹⁵¹ uses the ADEPT trial⁸⁸ of adalimumab versus placebo to estimate utility through a direct linear relationship with HAQ and PASI collected in the trial. The base case uses the SF-36, collected in the trial, converted to

TABLE 53 Utilities used in the cost-effectiveness models

	Regression estimates
^a Wyeth ¹⁵³	HAQ = -0.45586 (SE = 0.027047) Age = -0.00096 (SE = 0.000511) Gender = 0.020057 (SE = 0.012448) Age: HAQ = 0.003089 (SE = 0.000516) Male: HAQ = -0.03876 (SE = 0.011613) Intercept = 0.899592 (SE = 0.025597)
^b Schering-Plough ¹⁵²	Intercept = 0.6442260 (SE = 0.0115177) sHAQ = -0.1610008 (SE = 0.0087963) sPASI = -0.0375632 (SE = 0.0132345) sHAQ ² = -0.0050072 (SE = 0.0067073) sPASI ² = 0.0051515 (SE = 0.0030365)
^c Abbott ¹⁵¹	Intercept = 0.9144 (SE = 0.0186) HAQ = -0.2512 (SE = 0.0189) PASI_t = -0.0355 (SE = 0.0096)

PASI_t, transformed PASI $\log(\text{PASI} + 0.5)$; sHAQ, score HAQ; sPASI, score PASI.

a Random effects parameters also reported.

b Estimates from Brazier algorithm¹⁸¹ and split by psoriasis and non-psoriasis also available.

c Also reports for a model not including PASI.

EQ-5D. In a sensitivity analysis, data from the Bath Psoriatic Arthritis Database was used (no reference given). Again any interaction between HAQ and PASI was not explored.

There is some uncertainty regarding which of the industry regression models is appropriate to generate utilities.

Mortality

All of the industry models use UK life tables along with PsA specific mortality multipliers²⁹ to estimate mortality. Each also uses the same mortality rate for all treatments and no treatment (i.e. there is not differential impact of the alternative therapies on mortality). This assumption is reasonable, although there may be a beneficial effect of biologics on mortality; however, data to quantify this are not available.

Costs of treatment, start-up, administration and monitoring

Each industry model presents information, to a differing degree, on the resource use and unit costs used to cost drug treatment, administration of drugs and monitoring of patients. Of concern is the fact that in the Abbott model¹⁵¹ the total costs given in the report could not be replicated in terms of the resource use items and unit costs presented. These also appear to differ from the costs used in the model, where drug costs are split into direct and indirect costs with no accompanying definition provided in the report.

The *BNF*⁶⁵ was used to cost medications in the Wyeth¹⁵³ and Schering-Plough¹⁵² submissions. *MIMS*²¹⁶ was used in the Abbott submission.¹⁵¹ However, unit costs are consistent across the industry models: £419.62 per vial of infliximab, £89.38 per vial of etanercept and £357.50 per vial of adalimumab. Despite the consistency in unit costs, there are some differences in the medication costs for the industry models (*Table 54*). A number of differences in costing methodology explain this. First, different assumptions were made regarding the use of vials and patient weight for infliximab. The Abbott study¹⁵¹ assumes that four vials were used per infusion, based on an average patient weight of 80 kg. The Wyeth study¹⁵³ assumes a patient weight of 70 kg and allows vial sharing. The Schering-Plough study¹⁵² explores various scenarios to cost infliximab, using 60-, 70- and 80-kg weights for patients, in addition to the use of four and three and a half vials. All models assume that 5-mg infliximab is given per kg. Second, there are some differences in the number of vials used for the biologics in the different time periods. Schering-Plough¹⁵² and Abbott¹⁵¹ assume that three doses of infliximab are given in the initial 3-month period (at 0, 2 and 6 weeks). This is followed by doses every 8 weeks. Wyeth¹⁵³ gives infliximab at 0, 2 and 6 weeks and then every 6–8 weeks. Thus, four doses are given in the initial 3-month period, as opposed to three in the Schering-Plough¹⁵² and Abbott¹⁵¹ models. All three industry models assume that six vials of adalimumab are given in the first period. Abbott¹⁵¹ then assumes that seven vials are given in months 3–6, followed by six and a half vials in subsequent 3-month periods. Wyeth¹⁵³ assumes that six vials are given in all subsequent cycles. Schering-Plough¹⁵² assumes that six vials for the 3- to 6-month period, followed by six and a half vials for subsequent 3-month periods. All three models assume that 24 vials of etanercept are given in the initial 3-month period. Wyeth¹⁵³ continues to give 24 vials for all subsequent 3-month periods. Schering-Plough¹⁵² gives 24 vials for months 3–6, followed by 26 for subsequent 3-month periods. Abbott¹⁵¹ gives 28 vials in the 3- to 6-month period, followed by 26 vials in all subsequent periods.

TABLE 54 Costs used in the industry models

Manufacturer and time frame	Strategy	Costs (£)				
		Drug	Administration	Monitoring	Total	
<i>^aAbbott¹⁵¹</i>						
<i>From report</i>						
0–12 weeks ^b	Etanercept	2324	194.5		2518.5	
	Adalimumab	2324	194.5		2518.5	
	Infliximab	4196	1263		5459	
	DMARD	70.5	363.5		434 ^c	
12–24 weeks	Etanercept	2324	194.5		2518.5	
	Adalimumab	2324	194.5		2518.5	
	Infliximab	4196	1263		5459	
	DMARD	70.5	363.5		434	
24 weeks + (3-month costs)	Etanercept	2324	152		2476	
	Adalimumab	2324	152		2476	
	Infliximab	2727.5	1018.5		3746	
	DMARD	70.5	328		398.5	
<i>From model code</i>						
0–12 weeks	Etanercept	2145.12 (direct), 2239.64 (indirect)	236.73			
	Adalimumab	2145 (direct), 2239.52 (indirect)	236.73			
	Infliximab	5035.44 (direct), 5319 (indirect)	1507.73			
	DMARD	65.15 (direct),85.49 (indirect)	399.07			
12–24 weeks	Etanercept	2502.64 (direct), 2597.16 (indirect)	151.98			
	Adalimumab	2502.5 (indirect), 2597.02 (indirect)	151.98			
	Infliximab	3356.96 (direct), 3546 (indirect)	1018.48			
	DMARD	76.01 (direct), 93.96 (indirect)	328.04			
24 weeks + (3-month costs)	Etanercept	2323.88 (direct), 2418.40 (indirect)	151.98			
	Adalimumab	2323.75 (direct), 2418.27 (indirect)	151.98			
	Infliximab	2727.53 (direct), 2881.13 (indirect)	1018.48			
	DMARD	70.58 (direct),87.60 (indirect)	328.04			
<i>^dSchering-Plough¹⁵²</i>						
0–12 weeks	Infliximab	4 vials	5035	372	225.78	4374.36 ^e
		3.5 vials	4406			
		3 vials	3776			
	Etanercept	2145	394.09	225.78	2764.99	
	Adalimumab	2145	394.09	225.78	2764.87	

TABLE 54 Costs used in the industry models (*continued*)

Manufacturer and time frame	Strategy	Costs (£)				
		Drug	Administration	Monitoring	Total	
12–24 weeks	Infliximab	4 vials	3356	248	50.39	2816.11 ^f
		3.5 vials	2937			
		3 vials	2517			
	Etanercept	2145	0	90.40	2235.52	
	Adalimumab	2145	0	90.40	2235.40	
	24 week + (3-month costs)	Infliximab	4 vials	2727.53	201.5	54.59
3.5 vials			2386.58			
3 vials			2045.65			
Etanercept		2323.88	0	97.93	2421.81	
Adalimumab		2323.75	0	97.93	2421.68	
^gWyeth¹⁵³						
First 3 months	Etanercept	2145.12	71	66	2282.12	
	Adalimumab	2145	71	66	2282.00	
	Infliximab	5874.68	345.69	65.98	6286.35	
	MTX	9.11	0	144.64	224.75	
	Ciclosporin	498.23	71	139.95	709.17	
Between 3 and 6 months	Etanercept	2145.12	0	33	2178.12	
	Adalimumab	2145	0	33	2178.00	
	Infliximab	2937.34	230.46	32.99	3200.79	
	MTX	9.11	0	58.32	67.43	
	Ciclosporin	498.23	0	33.96	532.18	
6 months + (3-month costs)	Etanercept	2145.12	0	16.50	2161.62	
	Adalimumab	2145	0	16.50	2161.50	
	Infliximab	2937.34	230.46	16.49	3184.29	
	MTX	9.11	0	58.32	67.43	
	Ciclosporin	498.23	0	33.96	532.18	

a Do not give administration and monitoring costs separately and cannot derive using unit costs and resource use in report. The costs calculated do not tally with those used in the model. Drugs costs defined as direct and indirect in the R code, but no definition of what these are is given in the report.

b Using costs presented in the paper.

c Abbott used a weighted average of the DMARDs used in the University of Toronto database to calculate drug, monitoring and administration costs for DMARDs.

d Does not appear to include costs of methotrexate.

e Assuming three vials.

f Also reports for a model not including PASI.

g Administration and monitoring costs were not reported separately, but these have been calculated using resource use and unit costs given.

All of the three submissions state that they use the BSR guidelines to determine the resource use associated with administering drugs and monitoring patients; however, there are differences in the estimates of administration and monitoring costs in the various time periods.

The Abbott model¹⁵¹ assumes that etanercept and adalimumab were self-administered and incur the cost of a single outpatient visit (£115) in the initial 3-month period. This assumption was also made in the Wyeth¹⁵³ and the Schering-Plough¹⁵² models; however, an outpatient visit is assigned a cost of £222.71 in the Schering-Plough model¹⁵² and a cost of £71 in the Wyeth model.¹⁵³ The

Schering-Plough model¹⁵² also assumes an additional 4 hours of staff nursing time for follow-up (£150.58).

In the Abbott model,¹⁵¹ infliximab has a half-day care hospital cost assigned for each infusion (£462 multiplied by three infusions). This cost is taken from *NHS Reference Costs 2007–08* for a day case for inflammatory spine, joint or connective tissue disorders without complications. The Wyeth model¹⁵³ also assumes a hospital cost for each infusion of infliximab; however, this is much lower, at £115.23 per half day for each infusion, taken from published hospital costs.²¹⁷ The Schering-Plough model¹⁵² uses a cost of £124 per half day, citing results of a multiple technology appraisal (MTA).

In terms of monitoring costs, for the initial 3-month period the Schering-Plough model¹⁵² assumes a second outpatient visit for all biologics at £135.71 per visit. In addition, there is £90.07 of laboratory costs. This includes the cost of a full blood count (FBC), ESR, liver function test (LFT), urea and electrolytes (U&E) test, chest radiograph, TB Heaf test, antinuclear antibodies (ANAs) and DNA binding [double-stranded (dsDNA)]. Outpatients visits are then reduced to 0.23 of a visit for infliximab and 0.46 for etanercept and adalimumab in the 3- to 6-month period. Laboratory costs are also reduced to £19.07 for all biologics. In periods beyond 6 months patients receiving infliximab are assumed to require 0.25 of an outpatient visit, and patients being treated with etanercept and adalimumab are assumed to require 0.5 of a visit. Laboratory costs are £20.66 for all biologics.

The Wyeth model¹⁵³ assumes that all biologics patients will require one FBC at £5.50, one ESR at £3.86, one LFT at £12 and one U&E test at £11.64 in the first 3 months. For subsequent 3-month periods they will incur only 50% of these costs. The Abbott¹⁵¹ model assumes that all biologics patients will receive two FBCs at £15.19 each, two ESRs at zero cost, two LFTs at £8.43 each, two comprehensive metabolic panel (CMP) tests at £8.43 each and one chest radiograph at £27.25 in the first 3 months. In the subsequent 3-month periods, patients will receive tests at the same intensity, but will not require a chest radiograph.

Costs depending on Health Assessment Questionnaire and costs of psoriasis

Each of the models estimates the ongoing costs of PsA in relation to HAQ and PASI scores (Table 55). The Abbott model¹⁵¹ estimates the relationship between HAQ score and disease-related hospital costs using data on resource use by HAQ from the NOAR database. It is difficult to assess the validity of this approach, as the NOAR report used in the Abbott submission¹⁵¹ was not made available to the Assessment Group on request. As the NOAR data did not include any measure of uncertainty in the mean estimates of resource use, the estimates of the SEs of mean costs in the Abbott submission¹⁵¹ cannot be valid. The Schering-Plough model¹⁵² derives these estimates from the UK data of a study by Kobelt *et al.*,⁴¹ which was used in the previous York Assessment Group model. The Kobelt *et al.* data⁴¹ include the costs of RA drugs, primarily DMARDs. As per the previous York model, patients on biologic treatment incur only 85% of these costs, whereas those withdrawing from biologic treatment incur 100%. The Wyeth model¹⁵³ uses an evaluation by HODaR, utilising data from BSRBR and THIN to estimate the costs associated with HAQ. The THIN database does not include HAQ, thus variables in the BSRBR data set that were also available in the THIN data were used to predict HAQ values for the THIN data. A general linear modelling approach was taken and regression results from THIN were reported. However, prediction errors from the BSRBR/THIN regression were not included in the first regression of predicted HAQ values on to the observed costs. As such, the goodness of fit and uncertainty estimates do not reflect all of the uncertainty in the prediction. The costs used in the

TABLE 55 Costs associated with PsA as a function of HAQ and PASI used in each of the models

Costs (£)	
HAQ	PASI
Abbott¹⁵¹	
By HAQ score: ^a	PASI state 1: score = 1.5 (1.5 to 2.7) = 153.68 ^b
0.0 < 0.5 = 121 (59–173)	PASI state 2: score = 9 (7 to 11.2) = 933.62
0.5 < 1.0 = 77 (43–109)	PASI state 3: score = 15 (12.6 to 16.8) = 859.35
1.0 < 1.5 = 269 (141–382)	PASI state 4: score = 40 (32.4 to 43.2) = 1002.83
1.5 < 2.0 = 388 (206–550)	
2.0 < 2.5 = 909 (459–1295)	
2.5, 3.0 = 1945 (958–2778)	
Schering-Plough¹⁵²	
Constant: mean = 1325, SE = 466	(CiC information has been removed)
Slope: mean = 401, SE = 259	
Wyeth¹⁵³	
Does not present HAQ by score. Uses £2.05 per 3 months from sum of regression coefficients (also does this for SE). Cannot determine how this has been used in the model	

a Costs by HAQ score required for the model. Direct costs estimated by fitting an exponential line to the midpoint of each HAQ band.

b For 6 months.

Wyeth submission¹⁵³ are difficult to interpret and the costs by HAQ score are not presented. It is also not clear how estimates of uncertainty were derived.

The Abbott¹⁵¹ and Schering-Plough¹⁵² models both conduct separate physician surveys to assess the ongoing costs of psoriasis in relation to PASI. Abbott¹⁵¹ uses four hypothetical patients with differing PASI scores to generate costs. A logarithmic regression was then fitted to the median responses to estimate 6-month costs, based on a continuous PASI scale. It is not clear how many physicians were surveyed. Schering-Plough¹⁵² sample from 20 dermatologists to determine NHS costs associated with various PASI scores. The report does not say how the responses were synthesised. Wyeth¹⁵³ does not generate costs associated with PASI, as PASI was assumed to be a predictor of HAQ in their model. Each of the industry models relies on survey data to estimate the costs associated with psoriasis. This could be associated with a number of biases.

Patient subgroups

The Schering-Plough model¹⁵² reports results separately for psoriatic and non-psoriatic patients. For approximately one-third of patients with no clinically significant psoriasis (estimated from the IMPACT⁸¹ and IMPACT 2⁸² trials) only the change in HAQ is modelled. The PASI impact on HRQoL is not included for these patients. They do not consider variation in baseline HAQ.

The Wyeth¹⁵³ and Abbott¹⁵¹ models use the variation in baseline disease severity (measured using both HAQ and PASI) to explore the cost-effectiveness of treatments for subgroups. This is preferred to the approach used by the Schering-Plough model,¹⁵² as it allows the comparison of a greater number of subgroups, defined not only by the presence or absence of psoriasis, but also by their severity of disease according to PASI and HAQ.

Appendix 9

Generalising the results of randomised controlled trials to general practice

Introduction

Chapter 3, Results of review of clinical effectiveness, showed that biologic drugs are much more effective than placebo controls in the experimental setting. The RCT is generally accepted as the best method to estimate an unbiased measure of the relative effectiveness of the treatment, in this case versus a placebo control, whether that relative effect is measured on a proportionate scale, such as an OR, or as a difference in means between groups. However, RCTs are not necessarily predictive of the absolute effectiveness of the intervention in general practice.

Any medical intervention can be thought of as a complex set of factors, of which the active pharmaceutical ingredients are only one component, albeit usually an important one. Other components of the intervention might include the relationship between the doctor and patient, interventions by other health professionals, and the patient's expectations, all of which to a greater or lesser extent, and for better or worse, contribute towards the overall outcome. Selection effects, or 'regression to the mean', may also play a part. These 'non-pharmacological' components of the intervention can be thought of as acting equally in the intervention and placebo arms of clinical trials, assuming that both doctors and patients are blinded as to the treatment arm. In these circumstances, the effect observed in the placebo arm of the trial measures the effectiveness of these non-pharmacological components, while the 'treatment difference' measures the independent effectiveness of the pharmacological component of the intervention.

Predicting the absolute effectiveness of the intervention in general practice requires some assumption to be made about whether the protocols, procedures and general 'quality of care' of the RCT are similar to general practice. A Cochrane Review²¹⁸ found little evidence that using a placebo improved symptoms, with the exception of pain relief. However, the key question is not whether the 'placebo effect' is operating in every case, but whether outcomes associated with non-pharmacological components of the treatment are generalisable from RCTs to clinical practice. In other words, it matters less how the treatment works than whether it works.¹⁸⁹

This generalisability would not matter too much if the decision model were comparing 'placebo' with 'biologic therapy', as both groups would experience the same non-pharmacological components of therapy. However, NICE will not compare an active therapy with a placebo, even if it were shown to be effective: it compares active therapies with 'standard practice' which in this case is assumed to be palliative care only. Adding the doctor's caring to the medical care component of biologic therapy might affect the patient's experience of treatment and may, for example, reduce pain and affect outcome. The 'no-treatment' group might or might not receive equivalent non-pharmacological care.

We can represent these possibilities as two scenarios:

- *Scenario 1* The 'no-treatment group' receives similar care (with similar mean outcomes) to the placebo arm in an RCT.

- *Scenario 2* The ‘no-treatment group’ receives less care than the placebo arm in an RCT, and does not achieve the response rate of the placebo arm in an RCT.

Conceptual framework

Figure 8 shows the mean change in HAQ ΔY_{jr} from 0 to 12 weeks in the RCTs in the treatment group $j=1$ and placebo group $j=0$, depending on response, $r=1,0$. These parameters were estimated in the evidence synthesis in *Chapter 3*. Variable α represents the change in HAQ over 3 months if there is no response for patients with placebo. Variable δ represents the mean difference in the change in HAQ between placebo non-responders and placebo responders. Variable β_j represents the mean difference in the change in HAQ between placebo non-responders and non-responders with treatment, j . Variable γ_j represents the mean difference in the change in HAQ between placebo non-responders and responders with treatment, j .

The average change in HAQ (over responders and non-responders) in the placebo arm is:

$$\begin{aligned} \Delta Y_0 &= [p_0(\alpha + \delta_0) + (1 - p_0)\alpha] \\ &= \alpha + p_0\delta_0 \end{aligned}$$

We can represent these scenarios by our beliefs about the relationship between the NH (i.e. the change in HAQ N in 3 months observed in general practice with no treatment) and the change in HAQ for non-responders in a placebo group (α), if both ‘placebo’ and ‘no treatment’ were compared in general practice.

Scenario 1: Results with ‘no treatment’ in practice are similar to placebo arms of randomised controlled trials

If N is approximately equal to $\alpha + p_0\delta$ (the average change in HAQ in the placebo group), this represents a scenario where we think the results obtained in a group given placebo, averaged across responders and non-responders, would be the same as what would have been observed if no treatment had been given.

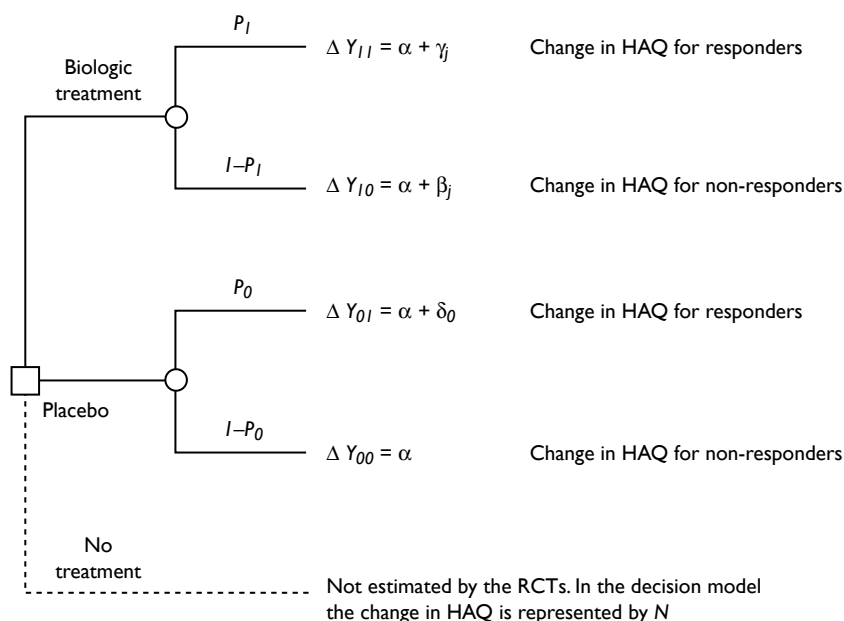

FIGURE 8 Change in HAQ from 0 to 12 weeks in treatment groups estimated by RCTs.

In scenario 1, the absolute difference in the change in HAQ between treatment in practice and no treatment (difference-in-difference) can be estimated by substituting $N = \alpha + p_0\delta$ into the parameters shown in *Figure 8* and so the difference-in-difference for responders is estimated to be $(\alpha + \gamma_j) - N + \alpha + \gamma_j - (\alpha + p_0\delta) = \gamma_j - p_0\delta$ and for non-responders $\beta_j - p_0\delta$.

Scenario 2: The ‘no-treatment group’, in practice, gets worse outcomes than the placebo arm in an randomised controlled trial

In this scenario, patients with no treatment would not achieve the response rates observed in the placebo arms of RCTs. It is assumed that they would have the same outcomes as patients with ‘no response’ in the placebo group of an RCT. This implies that N is approximately equal to α . In this scenario, if placebo were to be given in practice, there would be some lasting average benefit over and above NH equal to: $(\alpha + p_0\delta) - N = \alpha + p_0\delta - \alpha = p_0\delta$.

This might imply a lasting psychological benefit of the act of taking medication or could be due to beneficial interactions between the doctor and patient that occur both in trials and in the regular clinical setting. By extension, this ‘placebo effect’ would also partly explain the results in the treatment group, and would be expected equally in the trials and in general clinical practice. Therefore, we would expect that if biologic therapy and no treatment were compared in general practice, the absolute difference in the change in HAQ between treatment and no treatment (difference-in-difference) would be $\alpha + \gamma_j - N = \gamma_j$ for responders and β_j for non-responders.

It is difficult to test these alternative hypotheses, because the scenarios represent our hypothetical beliefs about a counterfactual argument: what would happen if ‘no treatment’, ‘placebo’ and ‘treatment’ were compared in general practice.

Conclusion

We conclude by setting out the implications for predicting the HAQ score in the decision model under each scenario.

In the decision model, variable N (the long-term NH in the untreated patients) is informed by observational evidence independent of the RCTs and is assumed to be constant over time. Therefore, in either scenario the HAQ score in the untreated group at time t after the start of the model is calculated as $N \times t$.

If responders on treatment are assumed not to progress (worsen) over time, then the HAQ(t,j) score at time t for responders while still on treatment j is:

- *Scenario 1* Results with ‘no treatment’ are similar to average in placebo arms of RCTs ($N = \alpha + p_0\delta$).

$$HAQ(t,j) = \alpha + \gamma_j = N - p_0\delta + \gamma_j$$

- *Scenario 2* The ‘no-treatment group’ achieves worse outcomes than the average in placebo arms of RCTs ($N = \alpha$).

$$HAQ(t,j) = \alpha + \gamma_j = N + \gamma_j$$

We assume that scenario 1 is the base case, consistent with the assumptions made in the previous Assessment Group model,¹⁷⁷ and that scenario 2 is a sensitivity analysis.

Appendix 10

Estimation of probability of achieving both Psoriatic Arthritis Response Criteria and Psoriasis Area and Severity Index 75 response

Introduction

Biologic therapy may be indicated to treat both joints disease and psoriasis. Clinical response at 3 months is measured using the PsARC for joints and PASI 75 for skin conditions.

Because there are two response variables, there are four possible outcomes at 3 months: skin response only, joints response only, response of both and response of neither. Furthermore, the PsARC and PASI 75 responses are not necessarily independent.

The meta-analysis in *Chapter 3* estimated the marginal probability of each type of response. However, this analysis did not estimate the bivariate probability, that is, the probability of observing both a response on arthritis and skin disease together.

This appendix shows how the bivariate probability density function (pdf) of PASI 75 and PsARC was estimated from the clinical trial evidence, to be used in the decision model for patients who have both skin and arthritis involvement at baseline, and assessed for PASI and PsARC responses at 3 months.

Estimate of correlation between Psoriatic Arthritis Response Criteria and Psoriasis Area and Severity Index 75 outcomes in the ADEPT trial⁵¹

No published papers reported the correlation between PsARC and PASI 75. The Assessment Group requested this from the manufacturers. One manufacturer (Abbott¹⁵¹) provided this data, based on the ADEPT trial,⁵¹ comparing adalimumab with placebo. In this appendix, we use the estimate of the correlation coefficient derived from the ADEPT trial⁵¹ and the estimates of the marginal pdfs of each type of response from the meta-analysis to estimate the bivariate pdf.

Table 56 shows the outcomes of the ADEPT trial,⁵¹ in the 66 patients who were assessed for both outcomes at 12 weeks. We refer to PsARC as variable x and PASI 75 as variable y . The responses are dichotomous, where 0 represents no response and 1 represents a response. To distinguish between the results of the meta-analysis and the results of the ADEPT trial,⁵¹ we label the pdfs from the ADEPT trial⁵¹ as $f(x)$ and $f(y)$ and the corresponding pdfs for the population estimated from the meta-analysis as $\Pr(x=1)$ and $\Pr(y=1)$. Similarly, the joint pdf from the ADEPT trial is $f(x,y)$ and the (predicted) joint pdf for the population as $\Pr(x=1,y=1)$.

The correlation coefficient $\rho = cov_{x,y}/s_x s_y$ [Equation 1]

where the trial estimate of $cov_{x,y} = E(XY) - E(X)E(Y) = f(x=1,y=1) - f(x=1)f(y=1)$

and the trial estimate of $s_x = SD(X) = \sqrt{f(x=1)[1 - f(x=1)]}$.

From the ADEPT trial, $cov_{x,y} = [29/66 - (34/66)(43/66)] = 0.103$

$$s_x = \sqrt{(43/66)(1 - 43/66)} = 0.500$$

$$s_y = \sqrt{(34/66)(1 - 34/66)} = 0.476$$

$$\rho = 0.103 / (0.5 \times 0.476) = 0.436$$

This value of ρ is significant at the 5% level [$t = 3.31$ with 65 degrees of freedom (df), $p = 0.0015$].

The SE is $SE(\rho) = \sqrt{[(1 - \rho^2)/(N - 2)]} = 0.112$, and t is distributed according to a Student's t -distribution with $N - 2$ df.

The ADEPT trial found that responses were uncorrelated for the placebo group, with an estimated correlation coefficient of 0.02 (Table 57) ($t = 0.16$, 67 df, $p = 0.87$).

Estimate of joint pdf of Psoriatic Arthritis Response Criteria and Psoriasis Area and Severity Index 75 in the population

We can use these relationships to estimate the bivariate probability of PASI 75 and PsARC in the population $\Pr(x = 1, y = 1)$.

We assume the correlation coefficient ρ between response types from the ADEPT trial is an unbiased estimate for all biologics in the population. This represents the correlation between outcomes in the population, and is a measure of *variability not uncertainty*.

TABLE 56 Outcomes of ADEPT at 12 weeks for patients in the adalimumab group, for patients with at least 3% body skin area affected by psoriasis at baseline ($n = 66$)⁵¹

PsARC (x)	PASI 75 (y)	n	$f(x,y)$
0	0	18	0.27
0	1	5	0.08
1	0	14	0.21
1	1	29	0.45

TABLE 57 Outcomes of ADEPT at 12 weeks for patients in the placebo group, for patients with at least 3% body skin area affected by psoriasis at baseline ($n = 69$)⁵¹

PsARC (x)	PASI 75 (y)	n	$f(x,y)$
0	0	49	0.72
0	1	2	0.03
1	0	17	0.24
1	1	1	0.01

$$\rho\rho = cov_{x,y} / s_x s_y$$

where s_x and s_y are estimates of variability of X and Y in the population, and not the uncertainty σ_x and σ_y in the mean $E(X) = \Pr(x=1)$ and $E(Y) = \Pr(y=1)$. An estimate of s_x in the population is $SD(X) = \sqrt{\Pr(x=1)[1 - \Pr(x=1)]}$

From the definition of the covariance [$E(XY) = \Pr(x=1, y=1) \times 1 \times 1 + \Pr(x=0, y=1) \times 0 \times 1 + \Pr(x=1, y=0) \times 1 \times 0 + \Pr(x=0, y=0) \times 0 \times 0 = \Pr(x=1, y=1)$]:

$$cov_{x,y} = E(XY) - E(X)E(Y) = \Pr(x=1, y=1) - \Pr(x=1) \Pr(y=1) \quad [\text{Equation 2}]$$

Rearranging *Equation 1* and substituting in *Equation 2* gives:

$$\begin{aligned} \Pr(x=1, y=1) &= \rho s_x s_y + \Pr(x=1) \Pr(y=1) \\ \Pr(x=1, y=1) &= \rho \sqrt{\Pr(x=1) \Pr(y=1) (1 - \Pr(x=1)) (1 - \Pr(y=1))} + \Pr(x=1) \Pr(y=1) \end{aligned} \quad [\text{Equation 3}]$$

The contingent probabilities of the joint outcomes are:

$$\begin{aligned} \Pr(x=1 | y=0) &= \Pr(x=1) - \Pr(x=1, y=1) \\ \Pr(x=0 | y=1) &= \Pr(y=1) - \Pr(x=1, y=1) \\ \Pr(x=0 | y=0) &= 1 - [\Pr(x=1) + \Pr(y=1) - \Pr(x=1, y=1)] \end{aligned}$$

There are constraints on $\Pr(x=1, y=1)$ and $\Pr(x=0, y=0)$:

$$\begin{aligned} \Pr(x=1, y=1) &\leq \Pr(x=1) \text{ and} \\ \Pr(x=1, y=1) &\leq \Pr(y=1) \text{ and} \\ \Pr(x=1, y=1) &\geq 0 \text{ and} \\ \Pr(x=0, y=0) &\geq 0 \text{ and} \\ -1 &\leq \rho \leq 1 \end{aligned}$$

Substituting *Equation 3* in these constraints, and rearranging, implies that:

$$\begin{aligned} \text{Max}\{-\sqrt{[\text{odds}(x=1) \times \text{odds}(y=1)]}; -\sqrt{1/[\text{odds}(x=1) \times \text{odds}(y=1)]}\} &\leq \rho \leq \\ \text{Min}\{\sqrt{[\text{odds}(y=1)/\text{odds}(x=1)]}; \sqrt{[\text{odds}(x=1)/\text{odds}(y=1)]}\} & \end{aligned}$$

where

$$\text{odds}(a) = \Pr(a) / [1 - \Pr(a)]$$

Implications for the decision model

We show an example of the implications of these assumptions for the decision model. For illustrative purposes, assume that the probability of PsARC for treatment j is estimated to be $\Pr(x=1) = 0.80$, and the probability of PASI 75 is $\Pr(y=1) = 0.5$.

In this example, $\text{odds}(x=1) = 0.8/0.2 = 4$ and $\text{odds}(y=1) = 0.5/0.5 = 1$. Given $\Pr(x=1)$ and $\Pr(y=1)$, the constraints on ρ are: $-0.5 \leq \rho \leq 0.5$

If we assume there is no correlation between these outcomes $\rho = 0$, then:

$$\Pr(x=1, y=1) = \Pr(x=1)\Pr(y=1) = 0.8 \times 0.5 = 0.4$$

$$\Pr(x=1, y=0) = \Pr(x=1) - \Pr(x=1)\Pr(y=1) = 0.8 - 0.4 = 0.4$$

$$\Pr(x=0, y=1) = \Pr(y=1) - \Pr(x=1)\Pr(y=1) = 0.5 - 0.4 = 0.1$$

$$\Pr(x=0, y=0) = (1 - \Pr(x=1))(1 - \Pr(y=1)) = 0.2 \times 0.5 = 0.1$$

If we estimate that the correlation between X and Y is $\rho = 0.5$, then:

$$\Pr(x=1, y=1) = 0.5 \times \sqrt{(0.8 \times 0.2 \times 0.5 \times 0.5)} + 0.8 \times 0.5 = 0.1 + 0.4 = 0.5$$

$$\Pr(x=1, y=0) = 0.8 - 0.5 = 0.3$$

$$\Pr(x=0, y=1) = 0.5 - 0.5 = 0$$

$$\Pr(x=0, y=0) = 1 - (0.5 + 0.8 - 0.5) = 0.2$$

Appendix 11

Elicitation exercise

A number of parameters within the model either did not have adequate evidence, or did not have any evidence at all, with which to populate them. This latter issue, in particular, poses a potential problem. One option would be to assign uninformative priors to these. However, this uninformative prior may not truly represent the current level of knowledge regarding these parameters. As an alternative to uninformative priors, elicitation techniques can be used to generate subjective priors for the unknown parameters in the absence of actual data.²¹⁹ An elicitation method is used to link an expert's underlying beliefs to an expression of these in a statistical form.

An elicitation exercise was designed to generate subjective prior estimates of the unknown parameters in the model, the effect of withdrawal from biologics, along with two other parameters for which evidence may be poor.

The following sections first describe the uncertainties and then go onto describe the elicitation exercise used to generate prior information to characterise these uncertainties. Finally, the results of the elicitation exercise are presented.

Uncertainties in the psoriatic arthritis model

The rate of disease progression beyond the initial Health Assessment Questionnaire change

The rate of progression following a response to etanercept or infliximab is uncertain. In the original York model, an assumption was made that beyond the initial HAQ gain, disease progression will stop (rate of progression = 0 in *Figure 9*) following response to biologics. There is some uncertainty, however, about the extent to which this truly reflects the longer-term efficacy

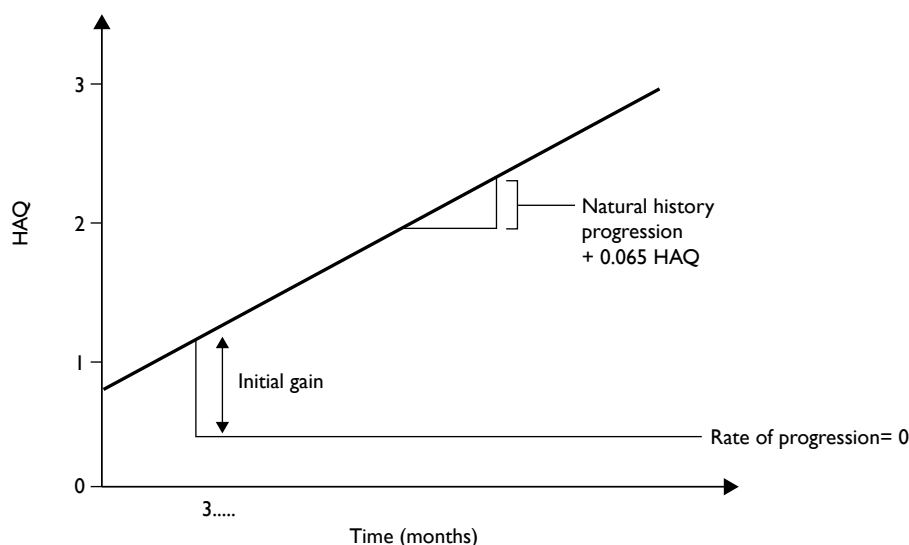

FIGURE 9 Natural history of PsA measured using the HAQ.

of biologics. Colloquial evidence suggests that patients may either improve their disease following a response to biologics or may experience some disease progression at a slower rate than the NH of the disease. Recent observational evidence from national biologics registers suggests that HAQ and health utility remain stable for patients with PsA while on biologics. Gulfe *et al.*¹⁹⁰ analysed data from 574 patients in south Sweden between May 2002 and December 2008, and found health utilities remained largely unchanged for PsA over 7 years. (CiC information has been removed.) The limitation of these registry data for the purposes of the decision model is that the data do not distinguish between outcomes for patients who persisted with their initial biologic and those who withdrew completely or switched to another drug.

In the original York model, progression following a response was simply assigned a fixed value of 0 and no scenarios were specified for this assumption. It is therefore not possible to determine the sensitivity of the model to this assumption.

The rebound effect

Patients who withdraw from biologic treatment, due to either adverse events or loss of efficacy, will then have some worsening in HAQ score (the 'rebound'). There are no data on the rate of disease progression for the 3-month period immediately following withdrawal from treatment (given an initial response on the PsARC criteria). Clinical opinion suggests that there will be some kind of rebound (back up to NH progression), but the degree of rebound is unknown. In the original York model, therefore, two rebound scenarios were considered (*Figure 10*):

1. When patients fail therapy (after initially responding), their HAQ score deteriorates by the same amount by which it improved when patients initially responded to therapy (rebound equal to gain in *Figure 10*).
2. When patients fail therapy, their HAQ score returns to the level and subsequent trajectory it would have been had they not initially responded to therapy (rebound to NH in *Figure 10*).

The two rebound scenarios for progression following relapse produced two different estimates of the cost-effectiveness of etanercept and infliximab. By specifying the rebound as equal to NH progression, the ICER for etanercept increases from £26,361 to £30,628 in the 10-year model compared with the rebound equal to initial gain. This increase in the ICER may be sufficient to change the adoption decision if the threshold is >£26,361, but <£30,628.

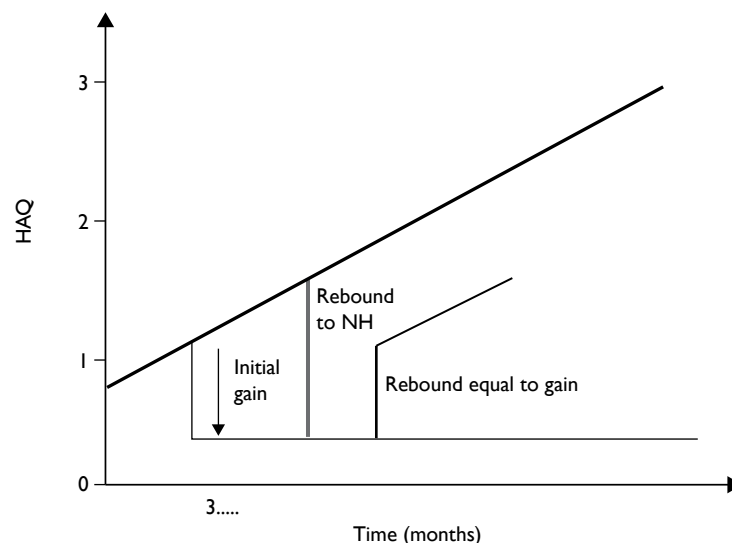

FIGURE 10 Disease progression following treatment failure.

The rate of disease progression beyond the rebound effect

The original York model assumed that following a change in HAQ after withdrawing from biologics (the rebound effect) patients would immediately return to the NH progression rate. Clinical opinion suggests that this might not be the case. That is when withdrawing from treatment, having received, and responded to, biologics alters the course of the disease for a given period of time after withdrawal. This issue was not explored in the previous York model.

Methods of the elicitation

The parameters described above were elicited from multiple experts individually, followed by appropriate synthesis. Clinical opinion suggests that the first two uncertain parameters may be correlated, i.e. the degree of rebound following relapse is conditional upon the extent of gain when responding. In addition, clinical opinion also suggested that extent of gain when responding may be conditional upon the extent of initial HAQ change following a PsARC response. The exercise, therefore, incorporates these relationships when eliciting data from experts.

To enable experts to express the extent of gain when responding conditional upon the extent of initial HAQ change following a PsARC response, this HAQ change was also elicited from experts during the exercise. These data are not used directly in the decision model, which takes estimates of initial HAQ gain from the evidence synthesis in *Chapter 3*.

Format and content of elicitation

A spreadsheet (EXCEL)-based, interactive elicitation exercise was designed to generate estimates of initial HAQ change, disease progression while responding to treatment, disease progression for the 3 months following a relapse and longer-term disease progression following withdrawal. An interactive format was used as the elicitation exercise was also designed to incorporate any correlation between the first three parameters. To build in the correlation between parameters, responses for some questions were conditional upon responses to previous questions. This method is an appropriate way to incorporate conditional dependence suggested by Garthwaite *et al.*²²⁰

In accordance with good elicitation practice, background to the elicitation was presented at the start of the exercise along with a guide to completion.²²¹ The background information presented can be seen below. Experts were told the rationale for the elicitation exercise, to obtain data on unknown parameters to inform a decision-analytic model, and reminded of the HAQ scoring method and expected NH progression (progression without treatment). Experts were presented with an illustration of the trajectory of disease progression without treatment and change in HAQ score. Experts were given examples of the question format and invited to complete practice questions.

The histogram approach²²² is used in this elicitation. For each question, a discretised numerical scale was predefined and experts were asked to place 20 crosses on a frequency chart, representing their beliefs about the distribution of a particular quantity. Each cross represents 5% of the distribution.

Once the expert had read through the supporting material and completed example questions, they were asked to start the elicitation questions. Experts were then taken to a separate worksheet where the four questions were arranged into sections, which they were asked to complete sequentially.

Initial Health Assessment Questionnaire gain following treatment with etanercept, infliximab or adalimumab

Experts were asked to provide an estimate of the known parameter (HAQ gain) following treatment with infliximab, etanercept or adalimumab. Experts could choose to group all three biologics together or complete separate histograms for each biologic.

Experts were asked for their estimates of HAQ score following treatment (3-month response) and were asked to place 20 crosses on a grid running from 0 to +3.

Rate of progression while still responding to treatment

Experts were asked to provide an estimate of disease progression for patients who have responded to treatment on etanercept, infliximab or adalimumab. Again experts could choose to group all three biologics together or complete separate histograms for each biologic. In addition, experts were asked if they believed that the rate of progression while responding was related to the initial HAQ gain (separately for each biologic if appropriate). If experts responded 'yes' they were requested to complete grids for each of the 0–25, 25–50, 50–75 and 75–100th percentiles from the WINBUGS output of HAQ score for infliximab, adalimumab and etanercept (see *Chapter 3, Assessment of effectiveness*). If experts responded no, they completed a single grid, assuming no relationship between the two parameters.

Again experts were asked to place 20 sets of crosses on each grid. Experts were reminded prior to answering these questions that we estimated the NH rate of progression of HAQ (progression without treatment) to be +0.016 per 3 months.¹⁷⁶

Rate of progression in the 3-month period after withdrawal from treatment

Experts were asked to provide an estimate of disease progression for the 3 months following a treatment failure (after an initial response); this was termed the 'rebound'. Again experts could choose to group all three biologics together or complete separate histograms for each biologic. In addition experts were asked if they believed that the rate of progression after withdrawal from treatment was related to the rate of progression while responding (separately for each biologic if appropriate). If experts responded yes they were requested to complete grids for each of the 0–25, 25–50, 50–75 and 75–100th percentiles. These ranges were generated by sampling from the responses to question 2, given the likelihood of observing a particular conditional HAQ gain (question 1). The likelihood of observing particular ranges for HAQ gain was again taken from the WINBUGS output of the current York model. If experts responded 'no', they completed a single grid, assuming no relationship between the two parameters.

Rate of progression following the 3-month rebound

Experts were asked to provide an estimate of disease progression for period following the 3-month rebound. Again, experts were reminded that this was for patients who had previously responded to biologics using the PsARC criteria but who had now withdrawn from treatment either due to adverse effects or loss of efficacy.

Experts were asked, for each of the three biologics, if they believed that the rate of progression would return to NH. If they answered 'yes' then the questionnaire was complete. If they answered 'no' then they were asked to complete a grid (for each biologic separately if appropriate) expressing their belief about the progression rate following the rebound period. They were then asked for the number of months they would expect to observe this progression rate before patients returned to NH.

Study sample

Sixteen experts were sent the questionnaire. These experts were chosen to represent a range of clinical opinion nationally. Experts were chosen on the basis of the clinical advice from a 'lead expert'.

Questionnaires were sent by e-mail, along with a covering letter. This format was chosen because of the wide national distribution of experts in the original sample of 16. Experts were then sent a reminder e-mail inviting them to complete the questionnaire. A number of experts expressed a desire to be guided through the questionnaire by telephone. The remainder completed the questionnaire independently and returned it via e-mail.

Questionnaire responses were received from five experts. A large number of the remaining 11 experts expressed a conflict of interest that prevented them from taking part in the exercise. The remainder stated that due to other commitments they were unable to participate. Experts were anonymised here and are referred to as experts 1–5.

Synthesis of experts' histograms

Linear opinion pooling is the synthesis method most commonly applied in expert elicitation.²²³ In linear pooling, experts' probabilities or weights are aggregated using simple linear combinations. If $p(\theta)$ is the probability distribution for unknown parameter θ in linear pooling, experts' probabilities or weights are aggregated using simple linear combination, $p(\theta) = \sum_i w_i \times p_i(\theta)$ where w_i is expert i 's weight.

This method is akin to generating a 'super' distribution by pooling the five experts' assessments. From this we can generate an arithmetic mean and associated uncertainty.²²⁴ This method assumes that by gathering more priors (eliciting from more experts) we do not necessarily become any more certain about the rate of progression during response or relapse. The linear pooling method considers each expert's distributions as separate priors with no relationship between experts' distributions assumed. Here linear pooling was carried out using equal weights for experts.

Results

Questionnaire responses

Responses to the elicitation questions varied, reflecting different clinical opinion regarding treatment. The histograms for each of the, questions, for each of the five experts are presented below. *Table 58* also shows the means and SEs of the means for each of the elicited parameters.

None of the experts expressed any difference between the initial HAQ changes for the three biologics. Elicited means ranged from 0.39 to 1, with a mean of 0.747. This figure is not dissimilar to the initial HAQ changes generated by the evidence synthesis model (see *Chapter 3, Assessment of effectiveness*). Many of the experts believed that HAQ progression for responders would be negative, i.e. patients would continue to improve over time while receiving biologics. The elicited 'rebound' effect is neither similar to the original 'rebound to initial HAQ gain' nor the 'rebound back to NH' scenarios. Experts believed that there was a continued effect of biologics even for patients discontinuing treatment due to either adverse events or loss of efficacy. Four out of five of the experts believed that long-term progression would be equivalent to NH.

Synthesised beliefs

Two of the experts stated that there was a correlation between initial HAQ gain and progression while responding to treatment and/or progression while responding to treatment and

progression for the 3 months after withdrawal from treatment. These correlations, however, were very small. Given the complexity involved in building this correlation into the decision model, it was therefore decided to assume that there was in fact no correlation between elicited parameters (as expressed by the majority of experts). *Table 59* shows the results from the synthesis of elicited parameters [mean (SE)] assuming no correlation between parameters.

The 'synthesised progression while responding' rate is very close to 0 at 0.002 (SE = 0.022). The rebound progression is 0.13 (SE = 0.14) increase in HAQ for 3 months. Again, this is somewhat different to the initial HAQ gain, contradicting the 'rebound to initial gain' assumption. It is further still from the 'rebound to NH' assumption.

Using the elicited data in the decision model

The elicitation was designed to inform the following three parameters in the decision model:

1. The rate of change of HAQ for patients on biologic therapies (*HAQ1.d*).
2. The change or rebound in HAQ in the 3-month period immediately after withdrawing from biologic therapy (*loss.w*).
3. The rate of change in HAQ in the long term after withdrawing from biologic therapy (*HAQ1.w*).

The base-case decision model will assume that the mean value of *HAQ1.d* is 0 (SE 0.02), consistent with the elicitation and the limited observational evidence from biologics registers.

For convenience, the decision model expresses the value of parameter *loss.w* relative to baseline HAQ. Its magnitude can be estimated as the difference between the absolute initial gain and the rebound. A value of 0 means that the rebound is equal in absolute terms to the initial gain on starting biologics, a positive value means the rebound is between the initial gain and 'NH', and a negative value means the rebound is less in absolute terms than the initial gain (see *Figure 9*). The results of the elicitation (see *Table 59*) suggest that *loss.w* is negative. Mean (initial HAQ gain) + mean (progression in 3 months after withdrawal) = $-0.75 + 0.13 = -0.62$ (SE = 0.29). Given the limitations of the exercise and some uncertainty about whether this accurately represents the views of the experts, we assume that the base-case mean value of *loss.w* is zero, with a normal distribution with a wide SE of 0.5 to indicate the considerable uncertainty. We use the mean value of *loss.w* = -0.62 as a sensitivity analysis.

The experts were almost unanimous that the long-term rate of change of HAQ after withdrawal would be equal to the rate of change of HAQ of patients who never used biologics (the NH). We therefore set these parameters to be equal in the decision model.

Discussion

There are a number of issues with the elicitation exercise that are worth noting. First it is likely that there is a degree of heterogeneity between experts. Possible reasons are clinical knowledge, clinical experience (types of patients seen and/or drugs used), interpretation and understanding of elicitation questions, and true underlying heterogeneity about the treatment effect. Unfortunately, it is not possible, with five experts, to incorporate these factors, as covariates, into a model. To do this would require many more experts to have any power to detect any difference.²²⁵

Second, the selection of experts for the elicitation questionnaire was undertaken by a single lead expert and the number of experts that completed the questionnaire was very limited. While

TABLE 58 Responses to elicitation questionnaire [mean change in HAQ in 3 months (SE)]

Expert	HAQ gain			Progression while responding			Progression in 3 months after withdrawal			LT progression after withdrawal		
	E	I	A	E	I	A	E	I	A	E	I	A
1	-1 (0.18)	-1 (0.18)	-1 (0.18)	-0.0035 (0.007)	-0.0035 (0.007)	-0.0035 (0.007)	0.08 (0.016)	0.08 (0.016)	0.08 (0.016)	0.016	0.016	0.016
2	-0.805 (0.135)	-0.805 (0.135)	-0.805 (0.135)	-0.009 (0.007)	-0.009 (0.007)	-0.009 (0.007)	0.393 (0.006)	0.393 (0.006)	0.393 (0.006)	0.016	0.016	0.016
3	-0.72 (0.16)	-0.72 (0.16)	-0.72 (0.16)	-0.017 (0.01)	-0.017 (0.01)	-0.017 (0.01)	0.013 (0.007)	0.013 (0.007)	0.013 (0.007)	0.02 (0.01)	0.019 (0.008)	0.02 ^a (0.008)
4	-0.82 (0.24)	-0.82 (0.24)	-0.82 (0.24)	-0.0017 (0.014)	-0.0017 (0.014)	-0.0017 (0.014)	0.037 (0.034)	0.037 (0.034)	0.037 (0.034)	0.016	0.016	0.016
5	-0.39 (0.17)	-0.39 (0.17)	-0.39 (0.17)	0.04 (0.011)	0.04 (0.011)	0.04 (0.011)	0.12 (0.007)	0.12 (0.007)	0.12 (0.007)	0.016	0.016	0.016

A, adalimumab; E, etanercept; I, infliximab; LT, long-term.

a This effect lasts for 6 months post rebound.

TABLE 59 Results from synthesis of elicited parameters [mean (SE)] (assuming no correlation between parameters)

HAQ gain	Progression while responding			Progression after relapse			LT progression					
	E	I	A	E	I	A	E	I	A			
-0.747 (0.268)	-0.747 (0.268)	-0.747 (0.268)	-0.747 (0.268)	0.002 (0.022)	0.002 (0.022)	0.002 (0.022)	0.13 (0.14)	0.13 (0.14)	0.13 (0.14)	0.0168 (0.004)	0.0166 (0.003)	0.0168 (0.004)

A, adalimumab; E, etanercept; I, infliximab; LT, long-term.

the problem with gathering sufficient experts is common in elicitation exercises conducted to inform HTA decision models, we cannot be sure that the sample of experts included is truly representative of the current level of knowledge.

Perhaps the most striking conclusion from the elicitation exercise is that the 'rebound' effect is neither similar to the original 'rebound to initial HAQ gain' nor the 'rebound back to NH' scenarios. Experts believed that there was a continued effect of biologics even for patients discontinuing treatment due to either adverse events or loss of efficacy. The majority of experts then believed that patients would return to a NH rate of progression beyond this rebound period. It is possible that the longer term implications of this were not clear in the exercise. In particular, the fact that by assuming that patients only return to NH rate of progression after this period meant that the progression of patients no longer on treatment would never return to the NH line of progression (see *Figure 9*). It is possible that the complexity of the exercise posed a significant cognitive burden on the experts. This may have been eased by including a visual expression of the resulting line of progression. Therefore, there may well be a trade-off between obtaining information on specific model parameters, the complexity of the exercise and cognitive burden on experts.

Background information presented to experts

Background information

In this questionnaire you are asked about the initial impact of anti-TNFs (etanercept, infliximab and adalimumab) on HAQ, the change in disease progression whilst responding to anti-TNFs, initial (3-month) progression of disease after withdrawal from treatment and longer term progression of disease after withdrawal.

The diagram opposite shows progression of PsA for untreated patients (natural history) using the Health Assessment Questionnaire (HAQ). The HAQ is a well validated tool in the assessment of PsA. It focuses on two dimensions of health status: physical disability (8 scales) and pain, generating a score of 0 (least disability) to 3 (most severe disability). A change in HAQ toward 0 is interpreted as a "HAQ gain" and a change toward 3 a "HAQ loss".

The questions we will ask you assume that the natural progression of disease is as shown in this diagram and can be represented using the HAQ. For the purposes of this questionnaire, baseline HAQ score for PsA patients is 1.16, with a 3-monthly natural rate of progression of

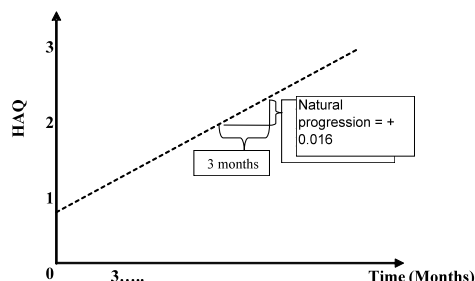

You will move through the questionnaire by right clicking (with your mouse) the question boxes. Some of the buttons may take a few seconds to move onto the next question. For some of the questions you will be asked to answer a simple yes/no. For some of the questions you will give your answer using a grid (see Figure 1 below). Each value along the horizontal axis represents a possible value for that particular question. The vertical axis represents frequency. We have given you 20 crosses per grid and we would like you to place all of these in some or all of the columns to represent your current belief and uncertainty about that particular question. You place a cross in the grid by left clicking (with your mouse) on a cell.

Please begin by placing 2 of the crosses at the upper and lower limits of your belief about the piece of data. You should then place the remaining 18 crosses so as to express your remaining uncertainty about the particular piece of data (see Figure 2 shown below). In red we show you how many crosses you have left.

If you change your mind about where you want to put your crosses simply press the CLEAR button and all crosses will be moved from the grid. You can also remove an individual "x" by clicking on it a second time. Once you are happy with your grid please press the 'submit your answer' button.

Figure 1: Example uncompleted grid

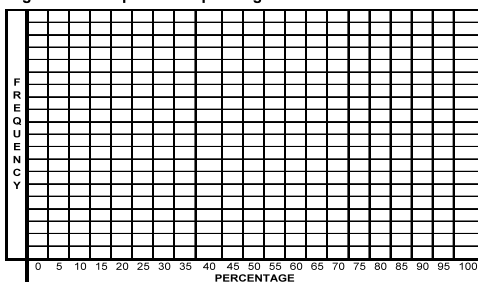
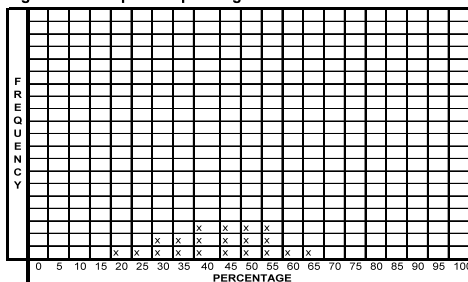

Figure 2: Example completed grid



Proceed to
'Examples'

Back to
introduction

Example of histogram used

What will the 3-month rate of HAQ progression be for patients responding to anti-TNFs?

Please place 20 crosses on the grid

Once you are happy with your answer please press the 'submit your answer' button

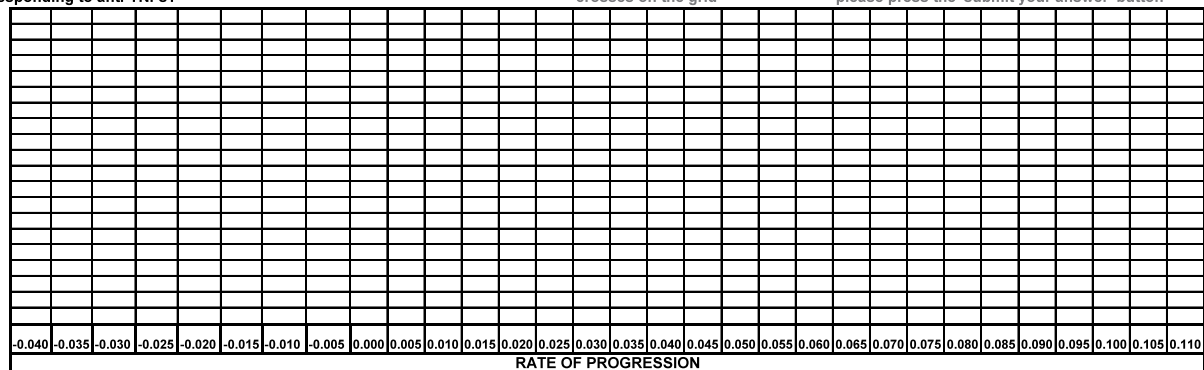

Clear grid

Submit your answer

Elicited histograms

Expert 1: Health Assessment Questionnaire gain (all drugs)

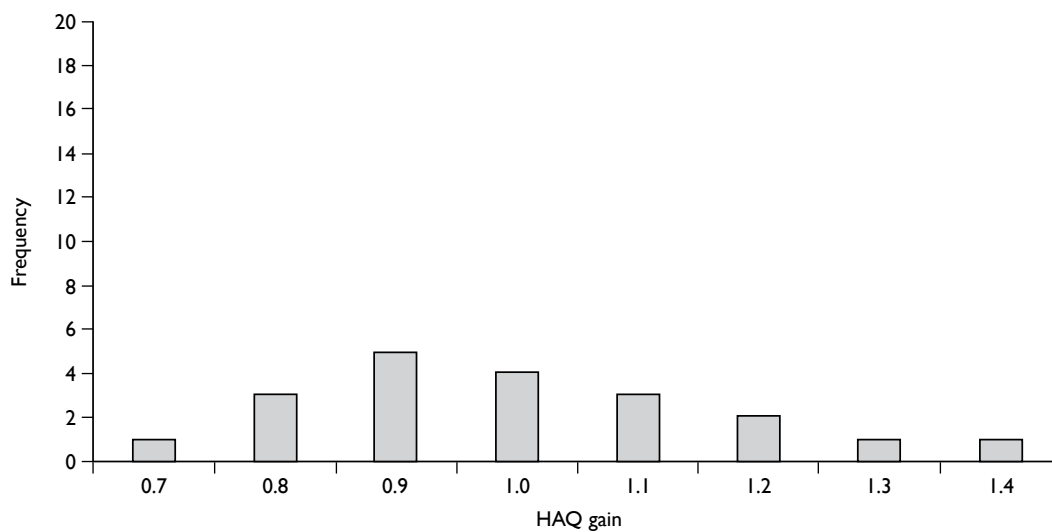

Expert 2: Health Assessment Questionnaire gain (all drugs)

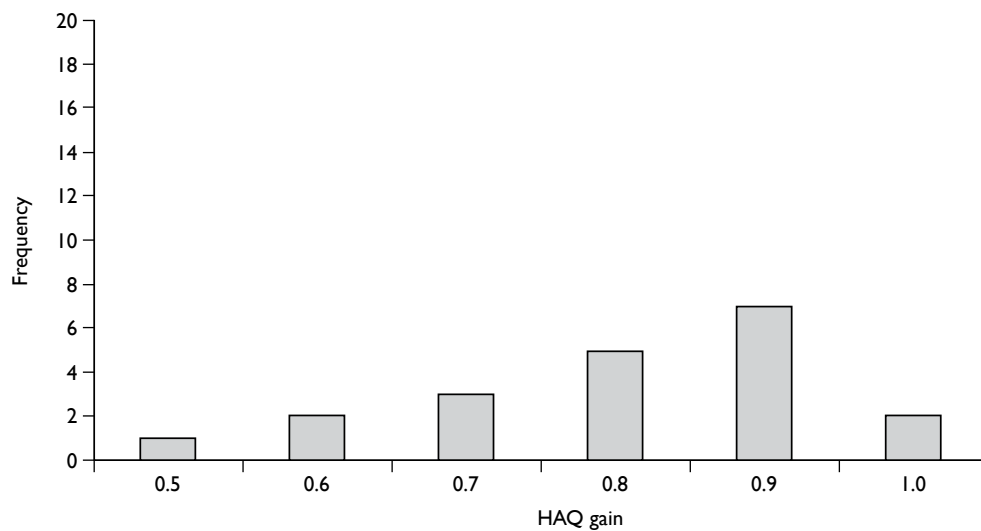

Expert 3: Health Assessment Questionnaire gain (all drugs)

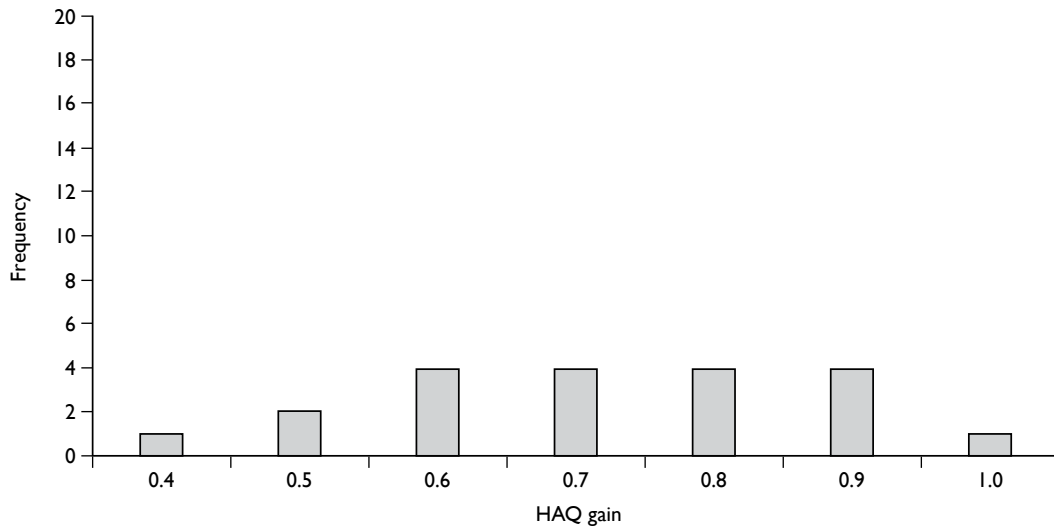

Expert 4: Health Assessment Questionnaire gain (all drugs)

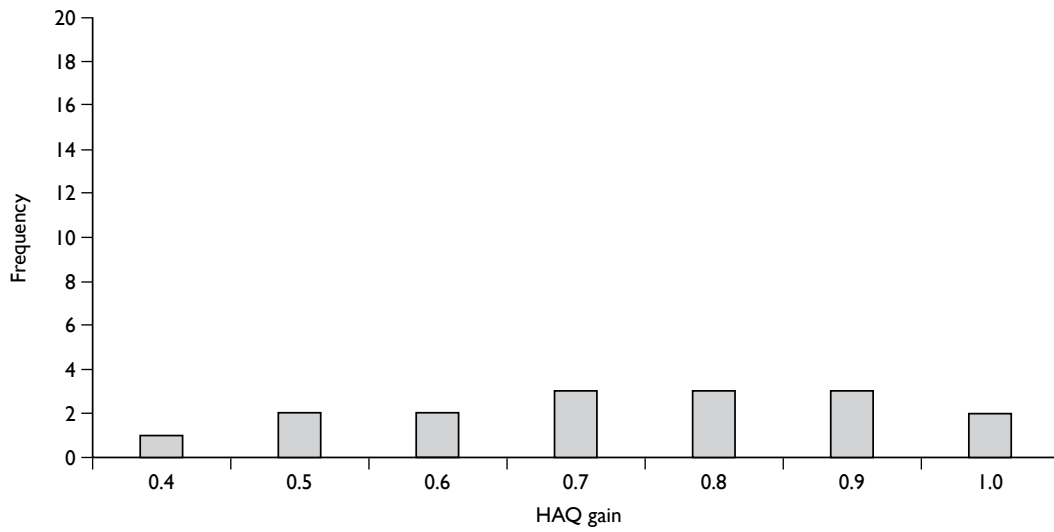

Expert 5: Health Assessment Questionnaire gain (all drugs)

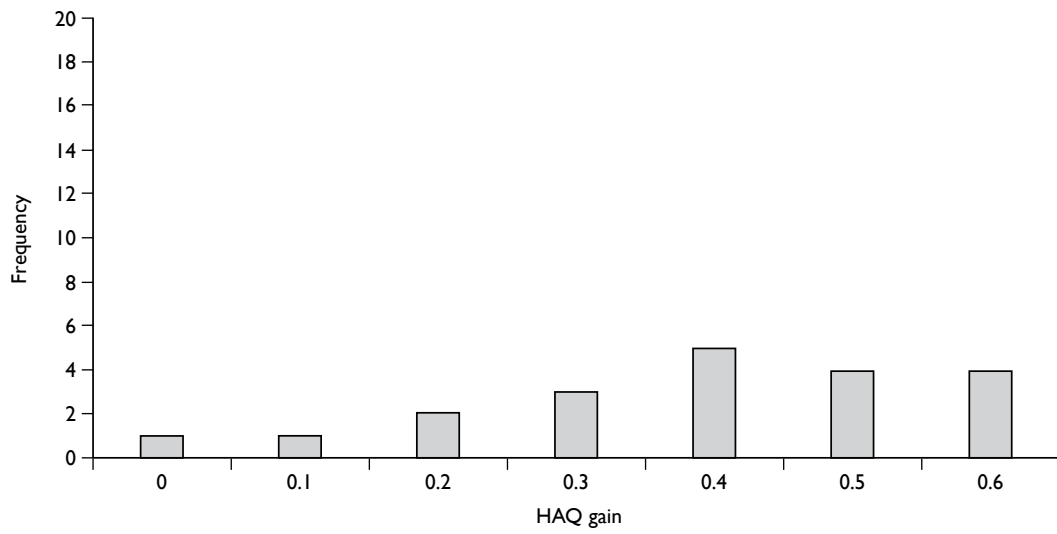

Expert 1: Progression while responding

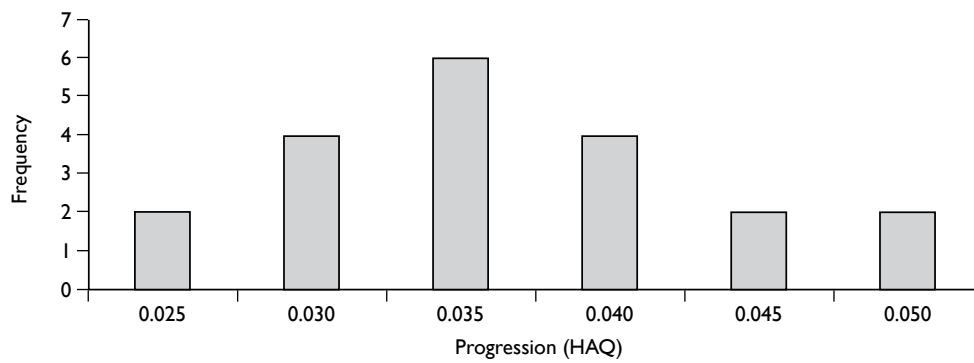

Expert 2: Progression while responding

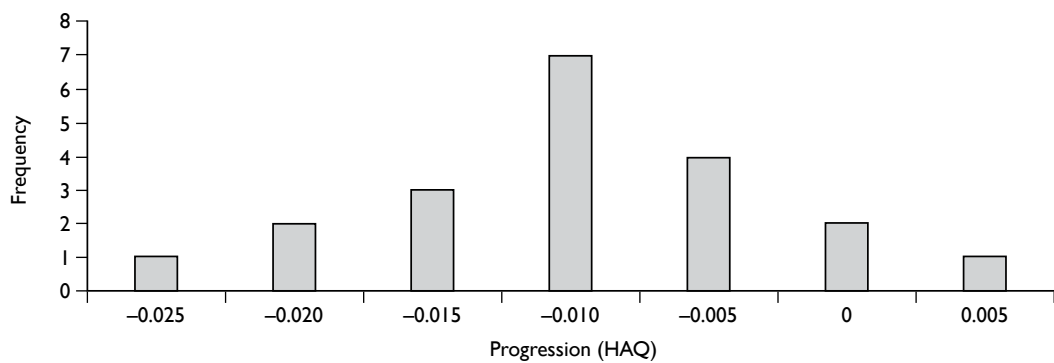

Expert 3: Progression while responding

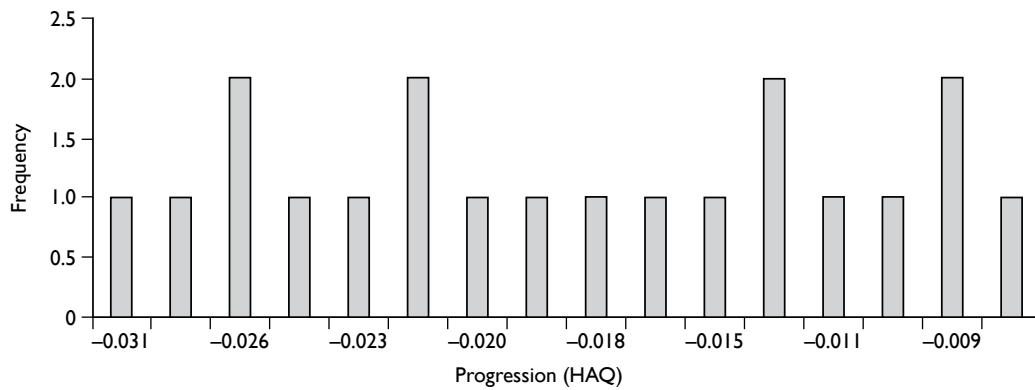

Expert 4: Progression while responding

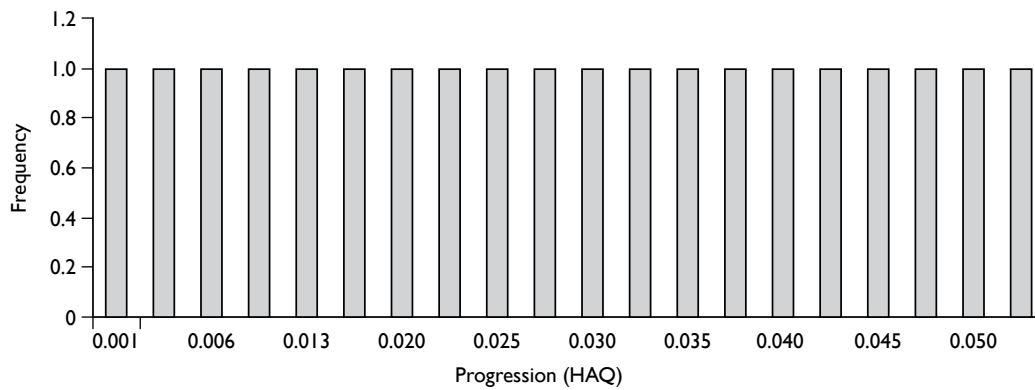

Expert 5: Progression while responding

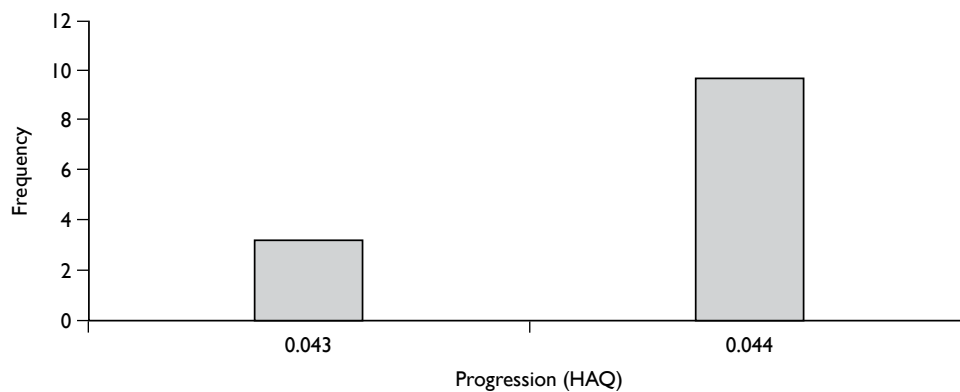

Expert 1: Progression during rebound period

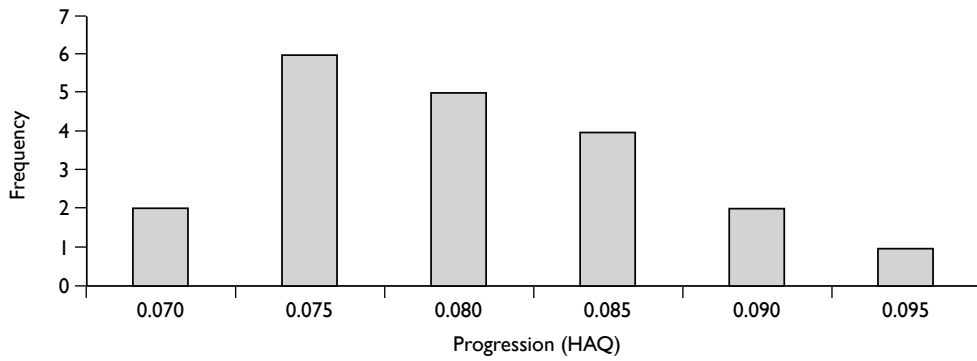

Expert 2: Progression during rebound period

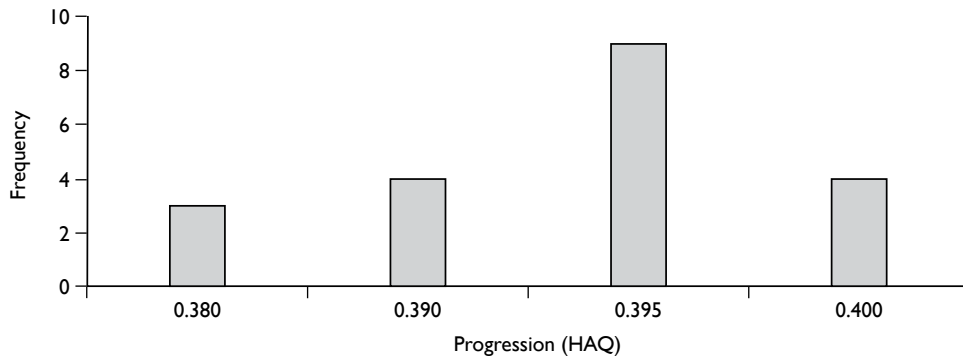

Expert 3: Progression during rebound period

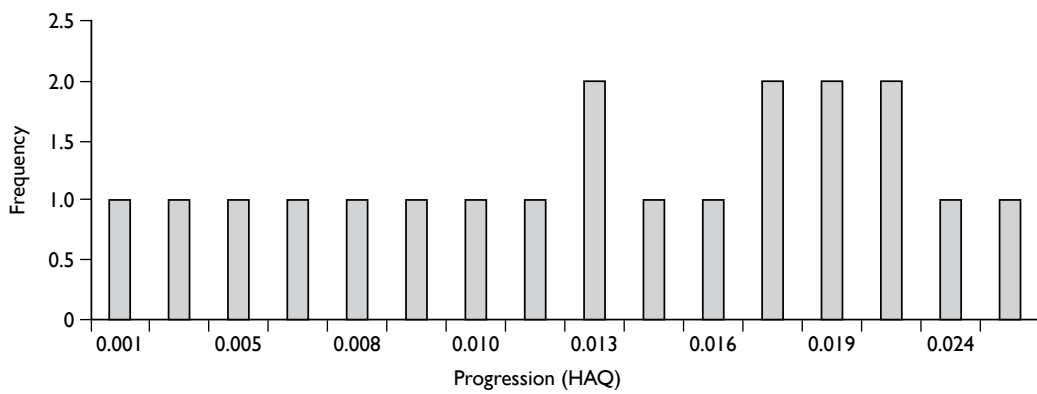

Expert 4: Progression during rebound period

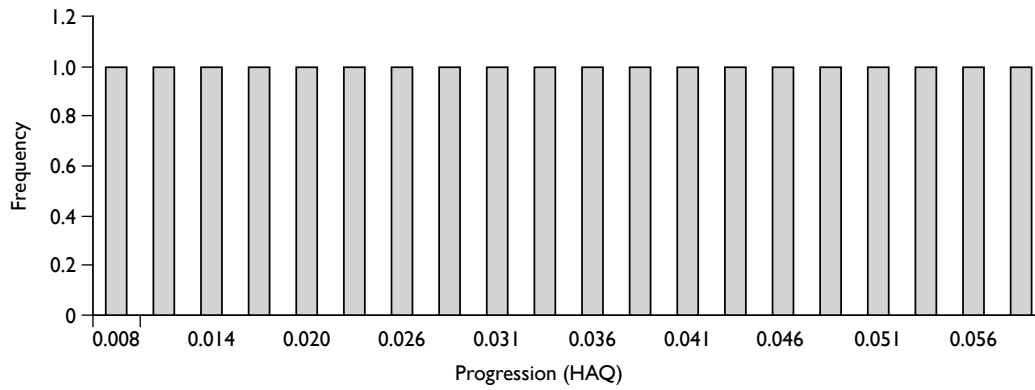

Expert 5: Progression during rebound period

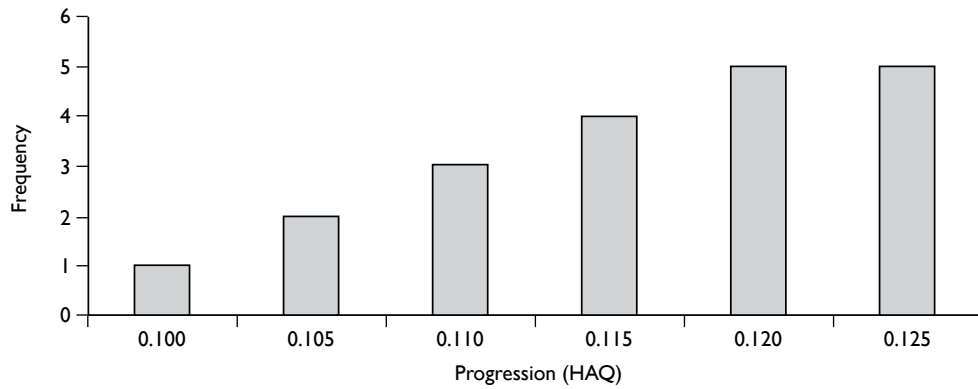

Appendix 12

Withdrawal rates from biologic therapies in patients with psoriatic arthritis

Introduction

This paper estimates persistence with initial biologics in patients with PsA. There are now registers in several countries that follow the progress of patients using biologic therapies and record the time to discontinuation. This paper undertakes a review of relevant registries to identify papers reporting drug discontinuation rates (or related data). A synthesis of relevant evidence is then undertaken in order to estimate the rate of withdrawal from initial biologic therapy. The paper considers whether this rate may vary over time, and whether there may be differences in withdrawal rates between etanercept, infliximab and adalimumab. All evidence is drawn from national biologic registers and is based on published summary data only. As withdrawal rates of patients with PsA are different from other types of chronic arthritis, all patients in this analysis have a diagnosis of PsA.

The estimates from the evidence synthesis will be used in a decision model, and extrapolated beyond the horizon of the studies to predict withdrawal over the patient's lifetime.

Methods

Literature search

A literature search was carried out to identify published papers from biologics registers of patients with PsA who reported survival probabilities of remaining on first biologic therapy at 3 months or more, and number of patients at risk or CIs to estimate the uncertainty in the parameters. The search strategies can be seen in the annex at the end of this section.

This search identified 154 publications of registry data that were potentially relevant. In total, 130 of these were excluded based on the abstract as they were found not to be relevant, therefore leaving 24 publications that were considered in full. Of these 24 publications the information available can be summarised as:

- reports rate of drug withdrawals, $n = 8$
- reports second-line success given reason for first-line failure, $n = 4$
- reports HAQ progression, $n = 14$
- reports PASI progression, $n = 1$.

Of the eight publications reporting rates of drug withdrawals, just six of these reported rates for patients with PsA separately, and in a format that could be used in the analysis. Data from patients registered between 2000 and 2006 in NOR-DMARD (Norwegian DMARD register) were published by Heiberg *et al.* (2008)²²⁶ and Heiberg *et al.* (2007).²²⁷ The latter was excluded as a majority of patients are likely to be included in both publications. Thus five publications were

included in the analysis. These were Kristensen *et al.*,²¹⁵ Gulfe *et al.*,¹⁹⁰ Gomez-Reino *et al.*,²²⁸ Saad *et al.*¹⁶² and Heiberg *et al.*²²⁶

Included studies

In the five papers included in the analysis, the majority report the average unadjusted Kaplan–Meier probabilities of survival, apart from Kristensen *et al.*,²¹⁵ who reported results stratified by use of concomitant MTX. Only one of the publication includes UK patients;¹⁶² Kristensen *et al.*²¹⁵ and Gulfe *et al.*¹⁹⁰ include Swedish patients, Gomez-Reino *et al.*²²⁸ include Spanish patients and Heiberg *et al.*²²⁶ include Norwegian patients. A brief summary of the papers is given in *Table 60*.

Kristensen *et al.*²¹⁵ (study 1) included 161 patients starting first biologic between April 1999 and September 2006 in the SSATG registry. Gulfe *et al.*¹⁹⁰ (study 2) included 344 patients, starting first biologic between May 2002 and December 2008 from the Southern Swedish Antirheumatic Therapy Group registry. We included data from both these publications in the evidence synthesis on the assumption that a minority of the patients would be included twice.

Table 61 shows the number at risk at the start of each follow-up and the probability of surviving on first biologic therapy until at least the end of the period.

Synthesis of registry data

The evidence synthesis is carried out using Monte Carlo Markov chain estimation. The model is based on a method for meta-analysis at multiple follow-up times by Lu *et al.* (2007).²²⁹

We define an ‘event’ as withdrawal from initial biologic therapy. The literature tends to report survival probabilities at a series of follow-up times, $Pr(T_j > t_u) = S(t_u)$, and the number observed at the start of each period N_{ju} (see *Table 61*). Unconditional survival probabilities are difficult to synthesise, as probabilities reported at successive time points in the same data set are correlated.

We therefore define the conditional probability of an event occurring between time u' and u in trial j for those who do not have an event up to time u as $F_{ju'}$. If T_j is the withdrawal time of patients in study j then:

$$F_{ju'} = Pr(t_{u'} < T_j < t_u | T_j < t_u) = 1 - S(t_u)/S(t_{u'})$$

TABLE 60 Summary of included studies

Author	Year	Register	Condition	No. patients at baseline	Biologic treatment?	Parameter(s)
Gomez-Reino 2006 ²²⁸	2006	BIOBADASER	PsA	289	Yes	1-year drug survival, first and second line Reasons for withdrawal
Kristensen 2008 ²¹⁵	2008	SSATG	PsA	261	Yes	~5-year drug survival for etanercept Risk of withdrawal relative to infliximab
Heiberg 2008 ²²⁶	2008	NOR-DMARD	PsA	172	Yes	1-year drug survival
Saad 2008 ¹⁶²	2008	BSRBR	PsA	566	Yes	1-, 2- and 3-year drug survival, reason for withdrawal Reported by individual drug
Gulfe 2010 ¹⁹⁰	2009	SSATG	PsA	344	Yes	~5-year drug survival for etanercept Risk of withdrawal relative to infliximab

BIOBADASER, Spanish Registry of Adverse Events of Biological Therapies in Rheumatic Diseases; NOR-DMARD, Norwegian DMARD register; SSATG, Southern Swedish Antirheumatic Therapy Group registry.

TABLE 61 Data used in the evidence synthesis

Study	Observational period																			
	1			2			3			4										
	Start	End	N	S	St/St-1	Start	End	N	S	St/St-1	Start	End	N	St	St/St-1					
1 ^a	1	12	161	0.82	0.820	13	24	103	0.72	0.878	25	36	54	0.6	0.833	37	48	17	0.5	0.833
2 ^b	1	3	344	0.902	0.902	4	6	216	0.81	0.898	7	12	144	0.699	0.863	13	24	136	0.598	0.856
3 ^c	1	12	289	0.87	0.870															
4 ^d	1	12	566	0.82	0.820	13	24	422	0.7	0.854										
5 ^e	1	12	172	0.773	0.773															

N, No. at risk at start of period; St, Probability of survival up to end of the period; Start/End, Start/end of observation period (months from start of the study); St/St-1, Probability of survival up to end of the period, given survival up to the start = St/St-1.

a Kristensen 2008²¹⁵ (south Sweden, patients with concomitant MTX).

b Gulfe 2009¹⁹⁰ (south Sweden).

c Gomez-Reino 2006²²⁸ (Spain).

d Saad 2009¹⁹¹ (UK).

e Heiberg 2008²²⁶ (Norway).

Note: Study 1 survival probabilities are read from a graph. Study 1 reported the number of patients at risk at 10-month intervals. Numbers at risk at the start of each year were interpolated from the data in the paper by estimating the average rate of censoring during the study and assuming that this rate was constant throughout the study.

where $t_{u'}$ is the beginning of segment u' and t_u is the end point of segment u' . The data $F_{ju'u}$ are conditionally independent. We index the time segments 1–3 months, 3–6 months, 6–12 months, 12–24 months, 24–36 months and 36–48 months by $u = 1, 2, 3, 4, 5, 6$. The observation periods are, therefore, made up of adjacent time segments, of unequal length. Not all studies report the same observation periods. For example, Saad *et al.* 2009¹⁹¹ reports survival probabilities at 12 and 24 months, while Gulfe *et al.*¹⁹⁰ 2009 reports survival probabilities at 3, 6, 12 and 24 months.

We assume that $F_{ju'u}$ is drawn from a normal distribution with mean $p_{ju'u}$ and variance $F_{ju'u} \times (1 - F_{ju'u}) / N_{ju'u}$. Other versions of the model might consider other distributions, such as the beta.

The hazard h_{ju} represents the failure rate of patients in trial j during segment u . The rate of withdrawal may vary over time. This might be represented in the model in various ways, such as a piece-wise constant hazard, or as a fully parametric function such as a Weibull distribution. The guidelines for the use of biologic therapies in PsA state that an assessment should be made at 3 months of whether the patient has responded on the PsARC and PASI 75 scales, and that drugs should be withdrawn or switched if there is no initial response.¹⁴⁹ Discontinuation after 3 months is likely to be a function of adverse events and/or continued response. It is therefore likely that the rate of withdrawal in the first 3 months is different from later time periods. Given we only have a few studies there is probably insufficient data to model changes in the hazard after the first 3 months. We therefore specify a piece-wise hazard that is constant after the first 3 months.

If an observation period spans segments u' to u , for a piecewise constant hazard:

$$\begin{aligned} p_{ju'u} &= 1 - \exp(-(H_{ju'} + \dots + H_{ju})) \\ &= 1 - \exp(-(c_{u'} h_{ju'} + \dots + c_u h_{ju})) \end{aligned}$$

The meta-analysis is undertaken on the log-hazard scale.

$$\begin{aligned} h_{ju} &= \exp(\theta_{ju}) \\ \theta_{ju} &= \mu_j + \nu I(u = 1) \end{aligned}$$

Parameter μ_j takes random effects, and ν is a constant in the base-case model. $I(u = 1)$ is an indicator function that takes value 1 if $u = 1$ and 0 otherwise. Parameter ν represents the additive effect of the first 3 months on the log-hazard scale. The prior of ν is a non-informative normal, but in principle might be informed by non-response rates at 3 months estimated by the evidence synthesis in *Chapter 3* (see *Results of review of clinical effectiveness*).

Differences in withdrawal between biologics

We conducted a meta-analysis of HRs for differences in withdrawal rates between biologics, assuming fixed treatment effects. Data were included from studies identified in the literature search that reported HRs for withdrawal for one biologic compared with another and its SE or CI. This analysis was conducted in STATA 10 using the 'metan' command.

Results

Results from the WINBUGS model are shown in *Table 62*.

TABLE 62 Results from the synthesis of withdrawal rates

Description	Mean	SE
Mean annual hazard in month 1 $\exp(\text{MU} + \nu)$	0.320	0.071
Mean annual hazard in month $m \geq 2$ $[\exp(\text{MU})]$	0.165	0.031
Between-study SE (log scale) (SE)	0.332	0.229

Note: the model constrains the hazards in study j in periods $m \geq 2$ to be equal.

The model predicts the pooled mean hazard is 0.17 per year across all studies and all drugs. The hazard is double in the first 3 months, and the predicted probability of withdrawal in the first 3 months is $1 - \exp(-0.32 \times 3/12) = 0.077$.

Two studies identified in the literature review^{162,215} reported HRs between therapies for discontinuation from first biologic for any reason for patients with PsA. Both studies adjusted for other factors using multiple regression in a Cox proportional hazards model. The data and results of the meta-analysis are shown in *Table 63*. Data from Kristensen *et al.*²¹⁵ have been read from a graph. The authors declined our request to provide the precise HRs and CIs (Pierre Geborek, Department of Clinical Sciences, Lund University, Lund, Sweden, 22 September 2009, personal communication).

Conclusions

- This study synthesises data on time to withdrawal from first biologic in patients with a diagnosis of PsA from national registries.
- The estimated rate of withdrawal after the first 3 months is 0.17 per year. This value will be used as the long-term withdrawal rate in the base case of the decision model.
- This rate is rather higher than the rate estimated in the previous appraisal of these drugs (0.11 per year), which was obtained from a longitudinal study of patients with RA in south Sweden, enrolled between March 1999 and November 2000.
- This analysis finds that, according to this observational data, on average 7.7% of patients withdraw in the first 3 months.
- This is much lower than the non-response rate on the PsARC scale recorded in the RCTs (about 16%). This might suggest that, in clinical practice, some patients remain on the drug even though they might not have achieved PsARC response at 12 weeks.
- This might be because of improvement in the skin condition (not captured by PsARC) and/or the clinician's belief that response might be achieved later than 12 weeks.
- There does not appear to be any difference in withdrawal rates between etanercept and adalimumab. Infliximab appears to have a significantly higher withdrawal rate than etanercept.
- However, these HRs between drugs may not be reliable.
- The HRs were estimated over the whole follow-up time, and do not distinguish between the first 3 months and later periods. Early withdrawal is a function of initial response, while later withdrawal is a function of continuing response and adverse effects
- Estimates of differences between drugs may be biased because infliximab was the first biologic to be marketed and may have been used on severe patients with low expectation of maintaining drug therapy.

TABLE 63 Hazard ratios for discontinuation from first biologic for patients with PsA

Study ^a	Mean HR ^b	Lower 2.5%	Upper 97.5%
<i>Etanercept vs adalimumab</i>			
Kristensen 2008 ²¹⁵	1.00	0.30	3.00
Saad 2009 ¹⁹¹	1.00	0.66	1.43
Pooled	1.00	0.68	1.46
<i>Etanercept vs infliximab</i>			
Kristensen 2008 ²¹⁵	0.50	0.30	0.90
Saad 2009 ¹⁹¹	0.36	0.27	0.47
Pooled	0.38	0.30	0.49

a Data from Kristensen 2008²¹⁵ have been read from a graph.

b HR value of '1' indicates that withdrawal rates are lower for etanercept than the comparator biologic.

Limitations

- As with all observational data, results may be subject to selection bias and confounding.
- Observed withdrawal rates are likely to depend on the options available to the clinician for switching patients to other biologics.
- The two studies from the south Sweden register may include some of the same patients.
- We assumed a normal distribution for probabilities. This should not be a problem if probabilities are not close to 0 or 1 and n is large.
- Withdrawal rates may be lower in patients receiving concomitant MTX. In this synthesis, one study²¹⁵ did not report average survival probabilities, but reported only results stratified by use of concomitant MTX or not. Excluding data from Kristensen *et al.*²¹⁵ increased the estimate of the withdrawal rate after 3 months from 0.17 (SE 0.03) to 0.20 (SE 0.72) per year, but the parameters failed to converge correctly.

Annex

Search strategy

Information was identified during a number of stages:

1. The ENDNOTE library *psoriaticarthritis2009-MASTER.enl* containing all the records identified by the searches was, in itself, searched for records containing the words 'register' or 'registry'. This identified 25 records.
2. A search of MEDLINE OvidSP (1950 to week 2, July, 2009) was carried out on 16 July 2009. The search strategy consisted of: Arthritis, Psoriatic/OR (psoria\$adj2 (arthrit\$or arthropath\$)).ti,ab. AND (register\$or registr\$).ti,ab. The results were scanned for relevance and 16 potentially relevant records were identified.
3. A search for named registries was carried out on 17 July 2009 on MEDLINE OvidSP (1950 to week 2, July, 2009), the named registries identified by the previous stages. This approach identified 112 additional records.

WINBUGS code

```
#Estimate parametric withdrawal rate from biologic therapy
#David Epstein Sept 2009
#PSA version 10
```

```

model{
#study, time
for (j in 1:12){
  F[ID[j],t[j]]<-1-S[j]#Conditional failure at follow up t, given survival up to end
  of t-1
  Prec[ID[j],t[j]]<-N[j]/(F[ID[j],t[j]]*(1-F[ID[j],t[j]]))#precision of F
  F[ID[j],t[j]]~dnorm(p[ID[j],t[j]],Prec[ID[j],t[j]]) #Likelihood for failures
}#loop j

#h are hazards, indexed i=study 1..4, m=time periods 1..up to 6
#time periods m are of different lengths of time:
#period 1 is 3months, 2 is 3months, 3 is 6months, 4,5 and 6 are all 12m
#each study might report survival probs at different set of follow up times
p[1,1]<-1-exp(-h[1,1]*0.25-h[1,2]*0.25-h[1,3]*.5) #ie follow up1 in study 1 is at 1 year
p[1,2]<-1-exp(-h[1,4]*1)#follow up 2 in study 1 is at 2 years
p[1,3]<-1-exp(-h[1,5]*1)#follow up 3 in study 1 is at 3 years
p[1,4]<-1-exp(-h[1,6]*1)#f up 4 in study 1 is at 4 years
p[2,1]<-1-exp(-h[2,1]*.25) #follow up 1 in study 2 is at 3months
p[2,2]<-1-exp(-h[2,2]*.25)#follow up 2 in study 2 is at 6 months
p[2,3]<-1-exp(-h[2,3]*.5)#follow up 3 in study 2 is at 1 year
p[2,4]<-1-exp(-h[2,4]*1)#follow up 4 in study 2 is at 2 years
p[3,1]<-1-exp(-h[3,1]*.25-h[3,2]*.25-h[3,3]*.5)# f up 1 in study 3 is at 1 yr
p[4,1]<-1-exp(-h[4,1]*.25-h[4,2]*.25-h[4,3]*.5)#f up 1 in study 4 is at 1 yr
p[4,2]<-1-exp(-h[4,4]*1)#f up 2 in study 4 is at 2 yrs
p[5,1]<-1-exp(-h[5,1]*0.25-h[5,2]*0.25-h[5,3]*.5) # follow up 1 in study 5 is at 1 year

for (i in 1:5) {# 5 studies
  for (m in 1:6) {#6 time points
    #step(e) = 1 if e >= 0; 0 otherwise. Acts like an 'if..then..else' statement
    theta[i,m]<-mu[i]+v*step(1-m)#fixed effect for v
    #theta[i,m]<-mu[i]+v[i]*step(1-m)#random effect for v
    h[i,m]<-exp(theta[i,m])
  }}

for (i in 1:5) {#5 studies
#mu[i]~dnorm(0,0.0001)#fixed study baseline
mu[i]~dnorm(MU,PREC)#random study baseline
#v[i]~dnorm(MU.V,PREC.V)#random study v
}

MU~dnorm(0,0.0001)#pooled value for mu
PREC<-pow(se,-2)
se~dunif(0,10)

v~dnorm(0,0.0001)#additional log-hazard in first 3months
#MU.V~dnorm(0,0.0001)#random v
#PREC.V<-pow(se.v,-2)
#se.v~dunif(0,10)

out[1]<-exp(MU+v) #mean hazard in month 1
out[2]<-exp(MU) #mean hazard in other months
out[3]<-se #between study variation in MU

```

```

}#end model

inits
list(MU=0,se=1,v=0,mu=c(0,0,0,0,0))#fixed v
list(MU=0,se=1,MU.V=0,se.v=1,mu=c(0,0,0,0,0),v=c(0,0,0,0,0))#random v

#data
#S[] is the conditional Pr(survival from t| given survival up to t)
#ie  $S[T>t|T>t-1] = S[T>t]/S[T>t-1]$ 
#study 1 is Kristensen 2008 with MTX, 2 is Gulfe 2009, 3 is Gomez 2006, 4 is Saad 2009,5 is
Heiberg 2008, 6 is Heiberg 2007 (not used)
#kristensen estimates read from a graph
ID[]N[]S[]t[]

1 161 0.82 1
1 103 0.878 2
1 54 0.833 3
1 17 0.833 4
2 344 0.902 1
2 216 0.898 2
2 144 0.863 3
2 136 0.8555 4
3 289 0.87 1
4 566 0.82 1
4 422 0.8537 2
5 172 0.77 1

```

Appendix 13

Costs used in the York model

Each of the industry models presents different resource use assumptions and unit costs, which are used to cost drug treatment and administration/monitoring of patients. Different assumptions are used regarding the dosing of drugs and resource use for administration and monitoring (see *Chapter 4, Comparison of the York Economic Assessment with the manufacturers' models*). The current York model sought to generate appropriate costs for each of the treatment options using clinical advice and BSR guidelines to determine the resource use associated with administering drugs and monitoring patients. These items are valued using recently published unit costs and prices. The following sections describe the assumptions made in costing, the associated resource use assumptions, unit costs and cost inputs for the decision model.

Resource use

The current York model assumes that infliximab vials cannot be shared and adopts separate scenarios regarding the use of three or four vials per patient. Infliximab is given at 0, 2 and 6 weeks, followed by every 8 weeks (1.625 every 3 months). Six and a half vials of adalimumab are given in every 3-month cycle. Twenty-six vials of etanercept are given in every 3-month cycle. These assumptions were made in consultation with an expert pharmacist (Carolyn Davies, Central Manchester University Hospitals NHS Foundation Trust, 2009, personal communication).

The York model also assumes a half-day inpatient hospital cost for each infusion of infliximab. A single outpatient visit is assumed for etanercept and adalimumab in the initial 3-month period, followed by a review visit between 3 and 6 months and then every 6 months thereafter.

In the York model it is assumed that, at baseline (in the initial 3-month period), patients will require a FBC, ESR, LFT, U&E, chest radiograph, TB Heaf test, ANA and a dsDNA test. All of these resource use assumptions are taken from the previous York model following the BSR guidelines for the use of biologics.

The resource use assumed as part of drug use, administration and monitoring for the various treatment options are shown in *Table 64*. All resource use was validated by clinical input.

Unit costs

All drug costs were taken from the recent version of the *BNF*.⁶⁵ The costs of inpatient hospital visits were taken from *NHS Reference Costs 2008–09*²³⁰ and is for an elective excess bed-day for inflammatory spine, joint or connective tissue disorders without complications. An inpatient day is assigned a cost of £144 per half day. The cost of an outpatient visit is also taken from *NHS Reference Costs 2008–09* and is for a follow-up visit in rheumatology. Each outpatient visit costs £116. Costs associated with laboratory tests relating to the monitoring of patents, were taken from the previous York model,¹⁷⁷ updated to reflect 2009 prices. All unit costs used in the current York model are shown below in *Table 65*.

TABLE 64 Resource use associated with drug administration and monitoring

Drugs	Administration			Monitoring								
	Visals per visit	Doses	Outpatient visit	Infusion cost	FBC	ESR	LFT	U&E	Chest radiograph	TB Heat test	ANA	dsDNA
0–3 months												
Etanercept	1	26	1	0	2	2	2	2	1	1	1	1
Adalimumab	1	6.5	1	0	2	2	2	2	1	1	1	1
Infliximab (four vials) ^a	4	3	0	3	2	2	2	2	1	1	1	1
Infliximab (three vials) ^b	3	3	0	3	2	2	2	2	1	1	1	1
3–6 months												
Etanercept	1	26	1	0	0.5	0.5	0.5	0.5	0	0	0	0
Adalimumab	1	6.5	1	0	0.5	0.5	0.5	0.5	0	0	0	0
Infliximab (four vials) ^a	4	1.625	0	1.625	0.5	0.5	0.5	0.5	0	0	0	0
Infliximab (three vials) ^b	3	1.625	0	1.625	0.5	0.5	0.5	0.5	0	0	0	0
6 months + (3-monthly)												
Etanercept	1	26	0.5	0	0.5	0.5	0.5	0.5	0	0	0	0
Adalimumab	1	6.5	0.5	0	0.5	0.5	0.5	0.5	0	0	0	0
Infliximab (four vials) ^a	4	1.625	0	1.625	0.5	0.5	0.5	0.5	0	0	0	0
Infliximab (three vials) ^b	3	1.625	0	1.625	0.5	0.5	0.5	0.5	0	0	0	0

^a Assuming no vial sharing, 5 mg/kg and patient weight of 70–80 kg.

^b Assuming no vial sharing, 5 mg/kg and patient weight of 60 kg.

Costs used in the current York model

The resource use items presented in *Table 64* were multiplied by the unit costs in *Table 65* to generate cost inputs for the decision model. Costs were calculated for the initial 3-month period, 3- to 6-month period, and all subsequent 3-month periods. These costs are presented in *Table 66*.

TABLE 65 Unit costs used in the York model

	£ (2009)	Source
Drugs		
Infliximab (100-mg vial)	419.62	<i>BNF 58</i> ⁶⁵
Etanercept (25-mg syringe)	89.38	<i>BNF 58</i> ⁶⁵
Adalimumab (40-mg syringe)	357.5	<i>BNF 58</i> ⁶⁵
Hospital costs		
Half inpatient-day	144	<i>NHS Reference Costs 2008–09</i> ²³⁰ – elective inpatient excess bed-day for inflammatory spine, joint or connective tissue disorders without complications
Outpatient rheumatology, first attendance	205	<i>NHS Reference Costs 2008–09</i> ²³⁰ – rheumatology outpatient first attendance
Outpatient rheumatology, follow-up attendance	116	<i>NHS Reference Costs 2008–09</i> ²³⁰ – rheumatology outpatient follow up
Laboratory tests		
FBC	2.74	York NHS Trust – 2005 costs updated to 2009
ESR	2.71	
LFT	0.69	
U&E	1.27	
Chest radiograph	24.04	
TB Heaf test	8.01	<i>NHS Reference Costs 2003</i> updated to 2009
ANAs	4.27	York NHS Trust – 2005 costs updated to 2009
DNA binding (dsDNA)	4.27	

TABLE 66 Costs used in the York model

	Drugs (£)	Administration (£)	Monitoring (£)	Total (£)
<i>0–3 months</i>				
Etanercept	2323.88	116.00	55.43	2495.31
Adalimumab	2323.75	116.00	55.43	2495.18
Infliximab (four vials)	5035.44	432.00	55.43	5522.87
Infliximab (three vials)	3776.58	432.00	55.43	4264.01
<i>3–6 months</i>				
Etanercept	2323.88	116.00	3.71	2443.59
Adalimumab	2323.75	116.00	3.71	2443.46
Infliximab (four vials)	2727.53	234.00	3.71	2965.24
Infliximab (three vials)	2045.65	234.00	3.71	2283.36
<i>6 months plus</i>				
Etanercept	2323.88	58.00	3.71	2385.59
Adalimumab	2323.75	58.00	3.71	2385.46
Infliximab (four vials)	2727.53	234.00	3.71	2965.24
Infliximab (three vials)	2045.65	234.00	3.71	2283.36

Appendix 14

Natural history of patients with psoriatic arthritis eligible for biologic therapy

Introduction

The decision model estimates long-term outcomes in terms of HAQ and PASI for patients with and without biologic therapy. As NICE would not recommend a placebo, the comparator is 'NH', a counterfactual state where no biologic therapy is available.

Previous decision models of PsA have estimated what the change in HAQ would have been if no biologic therapy had been offered. Bansback *et al.*¹⁷⁷ used data from a long-term, open-label follow-up of 35 patients who had originally been entered in a clinical trial comparing MTX with and without ciclosporin in the Leeds Musculoskeletal Unit. These patients had previously not been controlled on MTX alone. In total, 24 responses were received to a postal questionnaire. At the end of the trial, their mean HAQ was 1.13. After 'some 4.2 years' follow-up' (it is not stated if this is the maximum, minimum, mean or median), mean HAQ was 1.4, a mean annual change of 0.07 (SD 0.03).

Possible limitations of this analysis for the purposes of the current decision modelling are:

- Small sample size.
- Possibility of selection bias among responders to the postal questionnaire.
- Patients have failed one DMARD (MTX), rather than two as required by NICE guidelines.
- It is not stated in the paper if patients met the current guideline criteria for initiating biologics in PsA (three tender and three swollen joints).

No other published estimates were found of long-term outcomes in patients who had been uncontrolled on DMARDs. Morgan *et al.*²³¹ investigated outcomes in patients enrolled in NOAR between 1990 and 1994, with and without psoriasis. The median HAQ score for $n = 79$ patients with inflammatory polyarthritis plus psoriasis at baseline was 0.625 [interquartile range (IQR) 0.25 to 1.375] and was 0.75 (IQR 0.125 to 1.75) at 5 years, indicating a very small annual change in HAQ (0.025 per year). However, these data are not in patients who are necessarily uncontrolled with DMARD.

The NOAR data was reanalysed by the ARC Epidemiology Unit at the University of Manchester to estimate HAQ change in patients who are uncontrolled (with three tender joints three swollen joints) and have previously tried two or more DMARDs. This paper describes how HAQ progression was estimated and used in the decision model.

Methods

The NOAR database is a primary care-based cohort of patients with inflammatory polyarthritis. NOAR has been recruiting patients since 1990. Not all variables were assessed and recorded at

follow-ups for the cohort registered between 1995 and 2000 and so this cohort was excluded from the analyses. HAQ and other outcomes are recorded at annual follow-ups. Baseline is the visit when the patient was first seen by the research nurse to be included into the NOAR register. NOAR did not record a diagnosis of PsA. As patients with inflammatory polyarthritis plus psoriasis are thought to have similar prognosis to those who are seronegative without psoriasis, patients who were RF-negative at baseline were selected from the NOAR register. At each time point (baseline, year 1, year 2, year 3 and year 5) we evaluated whether patients fulfilled the following criteria:

- three tender joints (TJC) and three swollen joints (SJC) using the 51-joint count
- previous use of two or more DMARDs, implemented as all patients who had used two DMARDs or were still using two DMARDs for at least 30 days.

These criteria are intended to select patients who would be eligible for use of biologics. The BSR recommend that the 78 TJC and 76 SJC is used,¹⁴⁹ but this was not available in NOAR. The annual change in HAQ over the following 2 years was estimated from the time when a patient first fulfilled the criteria. The total score is based on the inclusion of all patients who fulfilled the criteria at different time points and their change in HAQ score since that time point. For example, from the data in *Table 67*, there were 216 patients in total: 24 patients at baseline, + 50 patients at year 1, + 46 patients at year 2, and + 52 patients at year 3 and + 44 patients at year 5. It is therefore possible that some patients are accounted for multiple times in the total score.

Results

The results are shown in *Table 67*. For all patients regardless of when they first became eligible for biologics, the data suggests that there was little change in HAQ over 2 years (mean annual change 0.00, SD 0.228) ($n = 216$).

For patients who met the eligibility criteria at baseline, their mean HAQ score at baseline was 1.55 (SD 0.84), and the mean change in HAQ over 2 years was -0.060 per year (SD 0.279) ($n = 24$). These patients had a median of 2.72 years from first onset of symptoms of disease until entry to NOAR. As a higher HAQ score represents worse disability, a negative change is an improvement.

For patients who met the eligibility criteria 3 years after entry to NOAR, the mean change in HAQ over 2 years was 0.077 per year (0.228) ($n = 52$), i.e. a worsening of disability. These patients had a median of 3.9 years from first onset of symptoms of disease until meeting the eligibility criteria for biologics.

The following sensitivity analyses were carried out:

- Patients who (had) used a DMARD/DMARDs for > 90 days at time of assessment were included in the analyses. In addition, patients who had used two or more DMARDs for at least 30 days were also included in the analyses.
- All patients who had used a DMARD/DMARDs or were still using a DMARD/DMARDs, irrespective of duration and number of DMARDs, were eligible at that time point.
- Tender and swollen joints assessed using the 28-joint count (DAS28).
- Patients with a nurse assessment of psoriasis as baseline.

The same trends observed in the primary analysis were also found in the sensitivity analyses.

TABLE 67 Change in HAQ for all patients who had used two DMARDs or were still using two DMARDs for at least 30 days

Years from baseline until patient first fulfils criteria	Median symptom duration at baseline	Mean (SD) HAQ score at baseline	No. of patients fulfilling criteria with 1-year follow-up HAQ score data available	Mean (SD) annual change in HAQ score measured over subsequent year	No. of patients fulfilling criteria with 2-year follow-up HAQ score data available	Mean (SD) annual change in HAQ score measured over subsequent 2 years
Baseline	2.72	1.55 (0.84)	27	-0.046 (0.513)	24	-0.060 (0.279)
1	0.99	1.52 (0.72)	53	-0.104 (0.427)	50	-0.019 (0.236)
2	0.69	1.41 (0.73)	68	0.029 (0.352)	46	-0.053 (0.214)
3	0.90	1.52 (0.73)	56	0.045 (0.389)	52	0.077 (0.228)
5	0.91	1.51 (0.74)		NA ^a	44	0.018 (0.180)
<i>Total score</i>			204	-0.011 (0.408)	216	0.000 (0.228)

a HAQ was not recorded 6 years after baseline, therefore the change from year 5 to year 6 could not be estimated.

Discussion

This paper has estimated the change in HAQ from the time at which RF-negative patients with inflammatory polyarthritis would have been eligible for biologics under current BSR guidelines. It finds that overall there is little or no change in HAQ over 1 or 2 years.

- For patients with symptoms for less than about 3 years before they became eligible for biologics, the data suggest that HAQ tends to improve over the following 1 or 2 years.
- For patients who have had symptoms of inflammatory polyarthritis for more than about 3 years before they became eligible for biologics, the data suggest that HAQ tends to worsen over the following 1 or 2 years.

These analyses have several limitations:

- The data set cannot identify patients with a consultant diagnosis of PsA.
- Biologics were licensed around the year 2000. Patients whose arthritis was not considered adequately controlled after this date would probably have been assessed against the criteria for biologics. In this study, we excluded patients who used a biologic agent at any time. Therefore, the patients who did not use biologics are likely to be those whose disability was less severe or progressed more slowly.
- The criteria for commencement of biologics require patients to satisfy three tender and three swollen joints twice at least 1 month apart, and in these data we only have a single measure.
- The criteria of three TjCs and three SjCs in some cases will be only moderate disease, and the patient and clinician might not consider that a failure. Patients in NOAR who satisfy the three TjC and three SjC criteria might go on to try other options such as increasing the dose of DMARDs, combination therapy or steroid injections.
- Patients in NOAR seem to satisfy the three TjC and three SjC criteria having been treated with two or more DMARDs for starting biologic therapy much earlier than patients in RCTs. This may be because RCTs tended to recruit patients who may have worse disease than the minimum entry criteria in the licence.

Conclusion

The York decision model will use as its base case the mean progression of HAQ for patients not using biologics estimated in the NOAR data in patients with long-standing disease (about 3 years since onset of symptoms), i.e. 0.077 per year ($SE = 0.228/\sqrt{52} = 0.032$). This value is very similar to that estimated by Bansback *et al.*¹⁷⁶ (mean change per year 0.07). Sensitivity analyses will estimate model results at the upper and lower CIs of this parameter.

Appendix 15

Impact of Health Assessment Questionnaire on health service costs

Introduction

This appendix reviews the published literature to estimate the impact of changes in functional status and disability, as measured by the HAQ, on health service and Personal Social Services costs. These estimates will be used in the decision model to predict health service costs over the patients' lifetimes.

Methods

This is a very broad literature and an exhaustive review was beyond the time constraints of this project. Instead, a rapid review was undertaken of the following sources:

- evidence presented to previous NICE appraisals of PsA treatments
- the manufacturers' submissions to the current appraisal
- PubMed in October 2009 with the search string: 'costs health assessment questionnaire arthritis'.

Relevant cost data for the economic model must satisfy the following criteria:

- The data should be relevant to patients with PsA. There are few cost data specifically measured in this disease, but many studies have analysed the relationship between HAQ and costs in other forms of chronic arthritis. It is assumed here that these data are generalisable to PsA. The cohort should include patients across the full spectrum of HAQ scores, from mild to severe disability.
- The data must show a causal relationship from HAQ to subsequent health-service utilisation and costs. Ideally, the analysis should exclude potential bias from confounding (the effect of other factors on both HAQ and costs) and endogeneity (the use of health services on subsequent disability). A retrospective or cross-sectional analysis, where patients are asked about their current disability and previous use of health services, might not capture the correct causal relationship. For example, surgery may improve function and so reduce HAQ. A prospective study design is therefore preferred, where HAQ is measured first and the costs are those accrued over the following period.
- The data should report mean costs conditional on HAQ and measures of sampling uncertainty. If the data are longitudinal, and individuals HAQ and subsequent cost are measured more than once during the study, then the analysis should properly account for the autocorrelation between repeated measures.
- The data should measure costs not charges or prices.
- Preferably data would be taken from the UK. Where this is not possible, it is important to assess whether studies from other countries are likely to be generalisable to the UK, particularly countries with mixed public/private financing such as the USA.

- The data should measure all direct health-care costs in the hospital, outpatient and community. Productivity losses should be reported separately. The base-case model excludes productivity losses in accordance with the NICE reference case.
- The data should estimate the costs of DMARDs and biologic separately from those of other health services. The economic model includes these costs separately from the effect of HAQ on costs.
- The study should have collected both HAQ and subsequent resource use as primary data and not use a proxy, such as expected HAQ predicted from other variables.
- The data should state the price year, the currency and other data to allow adjustment to the UK in 2009.

Papers were excluded if a rapid review of their title or abstract showed they did not meet one or more of the above criteria. The remainder were examined in more detail.

Results

The PubMed search identified 149 papers. There were three submissions by manufacturers to the current appraisal, and three submissions from the same manufacturers to previous NICE appraisals of biologics for PsA. Excluding duplicates, five papers were reviewed in more detail and their results are described below.

The estimates of costs used in the Wyeth submission¹⁵³ to the current appraisal was excluded because the IPD did not include HAQ, and the analysis used 'predicted HAQ' as a proxy. In *Chapter 4*, the section *Systematic review of existing cost-effectiveness evidence* gives more details of this study.

Kobelt et al.⁴¹

The Wyeth economic model¹⁵³ for the previous NICE appraisal of PsA¹⁸² estimated the direct costs as a function of HAQ based on data in Kobelt *et al.*⁴¹ The same source was used by the York Assessment Group to populate the economic model for the previous NICE appraisal¹⁸² and by Schering-Plough¹⁵² in their submission to the current NICE appraisal. The data published by Kobelt *et al.*⁴¹ are shown in *Table 68*.

The UK study began in 1987 and the cost component included 916 patients with RA with between 5 and 9 years of follow-up. Direct health-care resources were collected prospectively for all patients for hospitalisations, surgical interventions and RA medications. Details of outpatient visits and community services were collected retrospectively in a subsample of 107 patients. All observations for patients in a given state, at any year in the follow-up, were used to calculate the mean annual cost for each state. The paper states that few patients were in the worst HAQ state and no surgery was undertaken in these patients. The authors warn that results for this group may not represent general practice and should be treated with caution.

The analysis has several limitations. The paper does not explain the method of analysis used to estimate the costs in *Table 58* in much detail. It is not clear if repeated measures on the same patients were included in the analysis (as their HAQ evolved). As outpatient costs were only collected for a subsample of patients, it is not clear if imputation was used to estimate these costs in the other patients in the study. No indication is given of uncertainty in the primary data such as SEs or CIs. The price year used in the analysis is not stated, although is likely to be 1999 or 2000. *Table 68* shows the mean annual direct costs in 1999 US dollars (US\$) and 2008 UK pounds sterling (GBP) assuming purchasing power parity index of US\$ = 0.6542 GBP,²³² and the UK health sector pay and prices inflation factor from 1999 to 2008 is 1.36.²¹⁷

TABLE 68 Mean annual direct and indirect (productivity) costs estimated as a function of HAQ, in US dollars^{41,59}

HAQ score range	Proportion of patients ^a	Direct (1999 US\$)	Indirect (1999 US\$)	Total (1999 US\$)	Direct (2008 GBP)
0–0.6	0.35	1228	148	1,376	1094
0.6–1.1	0.16	3,152	2524	5676	2809
1.1–1.6	0.15	2091	3474	5565	1864
1.6–2.1	0.14	3087	5300	8387	2751
2.1–2.6	0.11	3401	8070	11,471	3031
2.6–3	0.08	2697	8407	11,104	2404

a Actual proportion of patients in the different disease states in the UK study during the longitudinal 9-year follow-up.

Bansback et al.¹⁷⁶

Based on the data in *Table 68*, Bansback *et al.*¹⁷⁶ carried out a linear regression and reported the coefficients as:

$$\text{Annual direct cost} = \text{£}358 \times \text{HAQ} + \text{£}1182$$

$$\text{SEs} = \text{£}231, \text{£}416$$

$$R^2 = 0.37$$

The study does not give much detail of the regression method used, but it is likely that this is an ordinary least-squares regression using the mid-point of the HAQ score as the independent variable and direct cost as the dependent variable, with six data points. If so then the SEs estimated in the regression do not correctly reflect the uncertainty in the mean of costs in the population, as each of these six data points is a sample mean conditional on HAQ score and has been measured with sampling error.

The assumption by Bansback *et al.*¹⁷⁶ that mean costs are a linear function of HAQ across all HAQ ranges does not appear to be supported by the data shown in *Table 68*. In particular, it appears that mean direct costs increase rapidly between the first and second HAQ band, but after this subsequent increases in HAQ do not seem to be associated with increasing direct cost, although the association seems stronger for indirect costs. However, there were few patients with severe HAQ states.

It is not clear if the regression estimates relate to the study price year 1999–2000 or have been adjusted for inflation to the price year used by Bansback *et al.*¹⁷⁶ (not stated by probably 2004 or 2005).

Kobelt *et al.*⁴¹ estimated that RA drugs, such as DMARDs, represent, on average, 13%–15% of direct costs. The previous York Assessment group model¹⁸² reduced the means and SEs of the regression estimates by 15% to populate the decision model. This adjustment assumes that DMARD use is a constant proportion of overall direct costs for all HAQ scores. If costs are reduced by 15% to reflect expenditure on DMARDs then mean direct health-care costs per 3 months in 2008 GBP are estimated as:

$$\text{£}358 \times 0.85 \times 0.25 \times 1.36 = \text{£}103 \text{ (SE 67)}.$$

Abbott submission,¹⁵¹ Wiles *et al.*²³³

The Abbott submission¹⁵¹ to the current appraisal is based on an analysis of resource use in the NOAR register. This is a UK primary care-based cohort established in 1989. The data from the Abbott submission¹⁵¹ are shown in *Table 69*.

The reporting of these data has several limitations:

- The Abbott submission¹⁵¹ states that the data are taken from Wiles *et al.*,²³³ a report commissioned by Roche as part of a previous NICE appraisal (rituximab). However, the Assessment Group has not been granted access to the original report by Wiles *et al.*²³³ Therefore, we cannot establish key details of how the data were collected or analysed.
- It is not stated if the cost data are prospective or retrospective, relative to when the HAQ assessment was made.
- It is not stated how many patients were included in the analysis in each HAQ range.
- It is not stated if HAQ is measured at baseline or longitudinally. If the latter, it is not clear if patients were included in the analysis more than once.
- It is not stated when the data were collected.
- It is not clear over what time period the data reported in *Table 69* were accrued. As the cycle length of the Abbott model¹⁵¹ is 3 months, we assume that the data in *Table 69* also represent resource use and costs over 3 months.
- No SEs or other measure of uncertainty are shown.

Based on these resource use data and published unit costs, Abbott¹⁵¹ calculated mean costs for each HAQ band. The 'IQR' estimates are based on the variability of mean unit costs between NHS hospitals in the NHS *Reference Cost* database.

Abbott¹⁵¹ fitted an exponential curve through the mean costs of the six HAQ bands.

$$\text{Direct cost} = \alpha \times \exp(\beta \times \text{HAQ})$$

The submission states that using the IQR, estimates of the values of α and β were calculated to be $\alpha = 54.1$ (SE 15.31) and $\beta = 1.237$ (SE 0.051). The β -coefficient can be interpreted as a unit change in HAQ on average leads to a 24% increase in expenditure.

These SEs for α and β are based on the variability of unit costs between providers, and do not properly reflect the uncertainty in mean costs conditional on HAQ. This should include uncertainty in the mean number of inpatient days and joint replacement procedures conditional on HAQ, which is not given in the data on which this regression is based.

TABLE 69 Resource use by HAQ band²³³

HAQ band	Inpatient days ^a	Joint replacement procedures ^a	Total cost (£), (IQR)
0.0–0.5	0.26	0.00	121, (59–173)
0.5–1.0	0.13	0.01	77, (43–109)
1.0–1.5	0.51	0.02	269, (141–382)
1.5–2.0	0.72	0.03	388, (206–550)
2.0–2.5	1.86	0.04	909, (459–1295)
2.5–3.0	4.16	0.05	1945, (958–2778)

^a Uncertainty is not reported around these estimates.

Pugner et al.³⁶

Pugner *et al.*³⁶ reviewed cost studies undertaken between 1978 and 1998 in patients with RA in eight countries (Europe, USA and Canada). They found that costs tended to increase more than proportionately to changes in HAQ, consistent with the exponential cost function used by Abbott.¹⁵¹ However, the data they present appear to be charges rather than costs and so are not suitable to use unadjusted in the UK setting.

Michaud et al.⁴²

This is a longitudinal study of 7527 patients completing a total of 25,000 semiannual (6-monthly) questionnaires from January 1999 to December 2001 in the USA. The study design and analysis have several features that suggest a high internal validity, although it is difficult to establish the degree of generalisability to the UK.

- Patients were recruited from the practices of US rheumatologists. Patients enrolled in the database as part of pharmaceutical company-sponsored registers were excluded from this study.
- The study is prospective, that is, HAQ was measured first and, subsequently, health service use.
- The data were collected during the era when biologics were licensed and entering clinical practice. About 25% of patients used biologic drugs.
- Direct costs are given in three categories: 'outpatient', including health-worker visits, medications, diagnostic tests and procedures, 'hospital costs' and 'drugs' including DMARDs, biologics, NSAIDs, gastrointestinal medications and non-RA drugs.
- The price year is given (2001).
- All direct medical costs are included, regardless of the payer. This is important because almost all medical expenditures are covered by the NHS in the UK. The paper presents data stratified by health insurer and for uninsured patients to allow the effect of financing on expenditures to be assessed.
- The study reports costs not charges.
- The analysis is based on primary data, allowing accurate estimation of uncertainty of the mean coefficients.
- The analysis uses generalised estimating equations, which accounts for the panel structure of the data and repeated measurements on the same individuals.
- The analysis uses multiple regression allowing control for other factors.
- Both log-linear and linear models of the effect of HAQ on costs were undertaken.

The results are shown in *Table 70* for the mean direct costs and the effect of HAQ on direct costs estimated in the multiple regression.

TABLE 70 Mean (SE) semiannual drug, hospital and procedure costs in RA (US\$, 2001)⁴²

	Drug costs		Hospital costs		Outpatient costs	
	Mean	SE	Mean	SE	Mean	SE
<i>Beta-coefficient from multivariable analysis^a</i>						
HAQ	434	43	325	46	112	14
<i>2001 direct medical costs for 7527 patients with RA, by cost type (per 6 months)</i>						
6-month cost	3162	38	786	31	770	10

a β -coefficients represent the expected difference in costs for a 1-unit difference in the predictor variable. Clinical variables are 'lagged' and therefore represent costs that occur in the 6 months following the clinical assessment.

The currency conversion index (purchasing power parity, 2008) is US\$ = 0.6542 GBP,²³² and the UK health sector pay and prices inflation factor from 2001 to 2008 is 1.31.²¹⁷ Given these conversion indices, hospital and outpatient costs as a function of HAQ are:

- change in 3-month hospital cost for a 1-unit change in HAQ = £139 (SE £20)
- change in 3-month outpatient cost for a 1-unit change in HAQ = £48 (SE £6).

There are limitations to the generalisability of these data to the UK.

Resource use is influenced by the type of insurance held by the patient and it is thought to be greater in fully insured individuals in the USA than the average in the UK. Michaud *et al.*⁴² found that for a given HAQ score, semiannual costs were US\$590 lower for drugs, US\$328 lower for hospital services and US\$235 lower for outpatient services for those having no insurance compared with similar individuals with private insurance, independently of HAQ. Income also influenced expenditure on outpatient procedures in the USA independently of HAQ.

Michaud *et al.*⁴² found that health indicators, such as fatigue and depression, and other clinical indicators, such as the Rheumatoid Arthritis Disease Activity score, influenced expenditure on outpatient procedures independently of HAQ. These are not measured in the current decision model. Relative unit costs may differ in the USA from the UK. If so, deflating or inflating by a constant conversion rate might not reflect expenditure patterns in the UK. Michaud *et al.*⁴² lists the unit costs in 2001 as US\$49.50 for a physician visit, US\$688 for a gall bladder procedure and US\$4083 for hospitalisation for conditions involving major joints of the lower extremity. In the UK, a specialist visit costs £253 (TCLFUSFF 313), a gall bladder day-case procedure costs £1389 (TDC GA10B) and major foot procedures £2963 (TEI HB31Z). Although it is difficult to match US DRGs with UK Healthcare Resource Groups, these data suggest that unit costs of outpatient and day-case procedures may be more expensive relative to inpatient procedures in the UK than in the USA.

The data do not include use of community nursing and nursing home services, which could be relevant to those with very severe disability.

Conclusion

This paper has reviewed published literature on the relationship between HAQ and costs of non-drug health-care services. *Table 71* compares the studies and their key strengths and weaknesses with respect to the decision model in the current appraisal.

The study by Michaud *et al.*⁴² has the highest internal validity, and appears to be the only study to correctly estimate SEs from the primary data, taking account of repeated measures on the same individuals. Michaud *et al.*⁴² estimated (in 2008 UK currency):

- mean change in 3-month hospital cost for a 1-unit change in HAQ = £139 (SE £20)
- mean change in 3-month outpatient cost for a 1-unit change in HAQ = £48 (SE 6)
- mean change in 3-month total cost for a 1-unit change in HAQ = £187 (SE 21).

The main limitation of these data for the decision model is that differences between the US and UK health-care systems limit the generalisability of these data to the UK.

TABLE 71 Cost studies and their key strengths and weaknesses

Study, years undertaken	Country, sample size, patient group	Resources covered	Strengths	Weaknesses
Kobelt 2002, ⁴¹ years 1987–96	UK, 917?, RA	Inpatient, outpatient (?), community (?)	UK data	Dated, few patients in severe HAQ state, includes RA drug costs, analysis poorly reported, no SE
Abbott 2005, ¹⁵¹ years unknown	UK, sample size unknown, IP	Inpatient	UK data	Analysis poorly reported, incorrectly calculated SE
Bansback 2006, ¹⁷⁶ years unknown	UK, 917?, RA	Inpatient, outpatient (?), community (?)	UK data	As Kobelt <i>et al.</i> , ⁴¹ incorrectly calculated SE
Michaud 2002, ⁴² years 1999–2001	US, 7527, RA	Inpatient, outpatient, diagnostic tests	Analysis based on IPD and clearly described, drugs separately reported	US data

IP, inflammatory polyarthritis.

The UK studies are poorly reported, and therefore it is difficult to be assured of their validity and precision. Based on the data in the Kobelt *et al.* study,⁴¹ Bansback *et al.*¹⁷⁶ estimated (in 2008 UK currency):

- mean change in 3-month total cost for a 1-unit change in HAQ = £103 (SE 67).

The mean costs per unit change in HAQ estimated by Michaud *et al.*⁴² are greater than those estimated by Bansback *et al.*,¹⁷⁶ and the SEs considerably smaller. However, given the limitations of the Bansback *et al.* analysis,¹⁷⁶ these data are not easily comparable. It is unclear whether the Kobelt *et al.* data⁴¹ include outpatient costs or not, whether the adjustment to the Kobelt *et al.* data⁴¹ for DMARD costs is correct, whether the Kobelt *et al.* data⁴¹ includes costs for the most severe patients, the price year of the Bansback *et al.* regression¹⁷⁶ is not stated and the SEs have not been calculated from the IPD in the Bansback *et al.* regression.¹⁷⁶

Despite these limitations, the mean coefficient represents a useful approximate linear relationship between HAQ and health service costs that is generalisable to the current decision model. The base-case decision model will use a linear relationship between HAQ and direct hospital and outpatient costs estimated by Bansback *et al.*¹⁷⁶ Drug costs will be estimated separately in the decision model. The intercept is not important to the decision model because it applies to all health states and all treatments in all cycles of the model. The Michaud *et al.* estimate⁴² and the Abbott estimate¹⁵¹ will be used in a sensitivity analysis.

Appendix 16

Impact of psoriasis on costs

Introduction

This paper describes the impact of psoriasis on health service and social care costs. These estimates will be used in the decision model to predict health service costs over the patients' lifetimes.

Psoriasis is a chronic skin disease that can seriously impair patients' QoL. Treatment often leads to a period of remission, after which further treatment is necessary. Therefore, the costs of psoriasis treatments can be substantial. A wide range of treatments are available including topical treatments, systemic drugs and photo(chemo)therapy.

Methods of literature search

A rapid literature search was carried out of the following sources:

- evidence presented to previous NICE appraisals of PsA and psoriasis treatments
- the manufacturers' submissions to the current appraisal
- PubMed in October 2009 with the search string: 'costs psoriasis'.

To be used in the decision model, estimates were needed of NHS health and/or social care costs according to the severity of psoriasis, for example, by PASI score, or expected costs of controlled and uncontrolled psoriasis according to some response criterion such as PASI 75. Ideally, the estimates of costs would be based on prospectively collected data on resource use in individual patients, rather than expert opinion. Data should be from the UK or a country with a similar universal, publicly-financed health-care system.

Results of literature search

Most estimates of costs or resource use in the literature were based on expert opinion. A previous model of psoriasis treatments¹⁷⁴ assumed one inpatient stay per year for patients with non-response of biologic therapy, based on expert opinion. The manufacturers' submissions from Abbott¹⁵¹ and Schering-Plough¹⁵² in the current appraisal of biologic therapies for PsA also estimated the costs of managing psoriasis, based on expert opinion. Abbott¹⁵¹ estimated that costs of managing psoriasis varied from £153 per 6 months for a PASI score of about 1.5, £934 for a PASI score of 9, £859 for a PASI score of 15 and £1003 per 6 months for a PASI score of 40. Schering-Plough¹⁵² estimated 3-monthly costs of managing psoriasis as £167 per PASI point if phototherapy was used and £53 per PASI point if phototherapy was not used (see *Chapter 4, Systematic review of existing cost-effectiveness evidence*). Two other economic evaluations of psoriasis treatments^{234,235} made similar assumptions to Woolacott *et al.*¹⁷⁴ based on expert opinion. Colombo *et al.*²³⁶ found the mean cost for patients with moderate plaque psoriasis (PASI ≤20) was €5226.04, while the mean cost for patients with more severe disease (PASI > 20) was €11,434.40 per year in Italy in 2004. Marchetti *et al.*²³⁷ estimated a year of fluocinonide therapy

for mild-to-moderate plaque psoriasis (<20% of BSA) would cost an average of US\$3394 in the USA at 1998 prices, corresponding to £788 per 3 months at 2008 UK prices.

Two studies were found that estimated costs in controlled and uncontrolled patients with moderate-to-severe psoriasis based on prospectively collected IPD. Hartman *et al.*¹⁸⁸ conducted a RCT in the Netherlands comparing day-case dithranol treatment, UVB therapy and inpatient dithranol treatment for 219 patients with a mean PASI at baseline of 15.3 (SD 6.9) and a mean BSA of 21% (SD 13.8%). Patients did not receive biologic therapy in the RCT. Resource-use data were collected on drugs, UVB sessions, consultations, nursing time, inpatient days, outpatient visits, primary health care, and time lost from normal activity. Hartman *et al.*¹⁸⁸ defined 'treatment success' as a reduction of the baseline area of at least 90% during the treatment period and 'relapse' as a return of 50% or more of the baseline area of psoriasis. Hartman *et al.*¹⁸⁸ report the numbers of patients who fail initial treatment, the number with initial success but relapse during the year and the number who have 1-year remission.

The results of Hartman *et al.*¹⁸⁸ are shown in *Tables 72* and *73*.

Poyner *et al.*¹⁹² recorded private expenditures and NHS costs (general practitioner consultations and treatments) for 272 patients with mild-to-moderate psoriasis after a 12-week course of either calcipotriol or dithranol. Mean health-care expenditure by the NHS over 6 months was £55.61 at 1999 prices (£79 at 2008 prices). The cost of treating psoriasis (excluding the initial course of treatment) was greater to the patient than to the NHS.

The mean NHS cost of an outpatient session of phototherapy is £116.¹⁸⁷ Guidelines suggest that patients typically undergo 4–10 sessions.²³⁸ Six sessions would cost £696.

Estimate of costs of psoriasis in the decision model

The decision model requires the health service costs of patients who do not use biologic therapies, or those whose psoriasis does not respond to biologic therapy, according to severity of psoriasis at baseline. Many of the studies in the literature review concluded that costs vary by baseline severity, although there does not appear to be a uniform classification of mild, moderate and severe psoriasis across the different studies, with some using PASI, some DLQI and others

TABLE 72 Direct health-care costs estimated by Hartman *et al.*¹⁸⁸ (€, 1998 prices)

	Initial treatment: mean, median (IQR) €	Per month without relapse: mean (€)	Per month after relapse: mean (€)
Day case	765, 723 (554–988)	19	264
UVB	600, 585 (458–744)	5	219
Inpatient	6823, 6380 (5200–8519)	25	220

TABLE 73 Outcomes at 1 year estimated by Hartman *et al.*,¹⁸⁸ excluding patients lost to follow-up

	<i>n</i>	Pr (treatment fails)	Pr (initial success then relapse within 1 year)	Pr (1-year remission)
Day case	94	0.37	0.24	0.39
UVB	70	0.41	0.35	0.25
Inpatient	52	0.09	0.65	0.26

the percentage of BSA. Reich and Mrowietz¹⁹⁵ define PASI > 10 or BSA > 10% as 'at least moderate', and PASI ≤ 10 as 'mild to moderate'.¹⁹⁵

For 'moderate-to-severe' patients, we assume that 'treatment responders' to biologic therapy, as measured by PASI 75, incur the monthly costs of patients in remission estimated by Hartman *et al.*¹⁸⁸ The initial treatment cost of UVB therapy estimated by Hartman *et al.*¹⁸⁸ is very similar to NHS *Reference Costs* for England, indicating that these data are likely to be generalisable to the UK. Patients who are not using biologic therapy, or not responding to biologic therapy, will undergo one course of UVB treatment per year. Of these, those that fail UVB treatment incur subsequent monthly costs estimated by Hartman *et al.*¹⁸⁸ for patients after relapse. Those that initially succeed but relapse during the year are assumed to be in remission for 6 months.

We choose UVB because it is a widely used therapy for moderate-to-severe psoriasis in the UK. Evaluating the most effective and cost-effective psoriasis treatment for patients who are not using biologic therapy or in whom biologic therapy is ineffective is beyond the scope of this study. We use the costs of inpatient dithranol as a sensitivity analysis.

The currency conversion rate in purchasing power parity is US\$ = €0.883 and US\$ = £0.654,²³⁰ and the inflation index from 1998 to 2008 is 1.42.²¹⁵

The mean cost of UVB in 2008 UK prices is:

- initial treatment = $600 \times 1.42 / 0.883 \times 0.654 = \text{£}631.04$
- per month without relapse = $5 \times 1.42 / 0.883 \times 0.654 = \text{£}5.26$
- per month after relapse = $219 \times 1.42 / 0.883 \times 0.654 = \text{£}230.33$.

Given these data, we estimate the annual cost for each health state following UVB as follows:

- annual cost if treatment succeeds = $631.04 + 12 \times 5.26 = \text{£}694$
- annual cost if treatment relapse at 6 months = $631.04 + 6 \times 5.26 + 6 \times 230.33 = \text{£}2045$
- annual cost if treatment fails = $631.04 + 12 \times 230.33 = \text{£}3394$.

The weighted mean annual cost if UVB treatment is given is therefore:

- mean annual cost = $3394 \times 0.41 + 2045 \times 0.34 + 694 \times 0.25 = \text{£}2262$.

The annual cost if the psoriasis were controlled by biologic drugs and no UVB treatment were given would be $12 \times 5.26 = \text{£}63$.

The mean costs of moderate-to-severe psoriasis used in the decision model per 3-month period are:

- for patients using biologics and achieving PASI 75 response: $\text{£}63/4 = \text{£}16$ (SE 1)
- for patients not achieving PASI 75 response from using biologics: $\text{£}2262/4 = \text{£}566$ (SE 25)
- for patients not using biologic therapy: $\text{£}2262/4 = \text{£}566$ (SE 25).

The SEs are calculated from the IQRs given in Hartman *et al.*¹⁸⁸ assuming normal distributions for costs. The costs of biologic therapies and the costs of treating disability are estimated separately in the decision model. If it is assumed that patients without biologics or without response of biologics will undergo one course of inpatient therapy per year instead of UVB, the cost increases to $\text{£}8532$ per year or $\text{£}2133$ (SE 93) per 3-month period.

For 'mild-to-moderate' patients, the treatment cost estimated by Marchetti *et al.*²³⁷ (£788 per 3 months) is US data and likely to overestimate the cost in the UK. We assume that patients with mild-to-moderate psoriasis who are not using biologic therapy or are uncontrolled by biologic therapy undergo one course of UVB therapy per year, costing £636.¹⁸⁷ The mean cost after treatment (averaged over responders and non-responders) is estimated from Poyner *et al.*¹⁹² The total cost over the year is $636 + 2 \times 79 = £794$.

The mean costs of mild-to-moderate psoriasis used in the decision model per 3-month period are:

- for patients using biologics and achieving PASI 75 response: £16 (SE 1)
- for patients not achieving PASI 75 response from using biologics: $£794/4 = £198$ (SE 9)
- for patients not using biologic therapy: £198 (SE 9).

Conclusions

This paper describes the impact of psoriasis on health-service costs for patients using biologic therapy and not using biologic therapy. The estimates used in the base-case decision model for mild-to-moderate patients are based on UK resource use and cost data. Costs are based on the results of a Dutch RCT for moderate-to-severe patients. The health system in the Netherlands is a social insurance system, but results are likely to be generalisable to the UK. This analysis does not account for adverse effects of repeated psoriasis treatments, such as skin cancers.

Appendix 17

Estimation of the effect of Health Assessment Questionnaire and Psoriasis Area and Severity Index on utility in the decision model

Introduction

Clinical benefit is captured in the decision model by estimating expected HAQ and PASI at each time point at each state in the model (on and off biologic drugs). This appendix describes the relationship between HAQ, PASI and utility (a preference-based measure of HRQoL).

Methods

Chapter 4, Systematic review of existing cost-effectiveness evidence describes the Assessment Group's critical review of the manufacturers' submissions to the current appraisal. Each company analysed the relationship between HAQ, PASI and utility in a different way. It was difficult to assess whether differences in these results arose from differences in the primary data or from the chosen method of analysis. Consequently, the Assessment Group requested that each company estimate a similar regression analysis on their data, to assess whether results were comparable (see *Appendix 6*). The Assessment Group requested that the analysis should be an ordinary least-squares regression of utility versus HAQ, PASI and an interaction term HAQ×PASI.

Results

All three manufacturers reanalysed their data and the results are shown in *Table 74*.

Conclusions

The results of these regressions are similar in all data sets. This indicates that the relationship between HAQ, PASI and utility is stable across independent clinical trials, and gives us confidence that the results are generalisable to the general population.

The interaction between HAQ and PASI does not reach statistical significance at the 5% level in any data set, but is very close to the 5% level in the Abbott data.¹⁵¹

The results of the regressions in *Table 74* are very similar and the decision about which data set we use in the York model is not likely to change the conclusions. We use the Wyeth results¹⁵³ without the interaction term as the base case and other functions as sensitivity analyses.

Appendix 18

Estimation of Psoriasis Area and Severity Index score for treatment responders in the decision model

Introduction

The PASI is a scoring system to evaluate baseline and response of therapy in psoriasis. The BAD¹⁷³ recommend PASI 75 for measuring primary response of psoriasis in patients with PsA. PASI 75 is a binary outcome that indicates a 75% or greater improvement in PASI from baseline. RCTs commonly report this and other measures of response, such as PASI 50 and PASI 90. In *Chapter 3*, the section *Results of review of clinical effectiveness* estimates the mean probability across all trials of achieving PASI 50, PASI 75 and PASI 90 for each biologic therapy and placebo using summary data from the RCTs.

These multivariate response indicators (PASI 50/75/90) indicate the probability of achieving a *minimum* percentage improvement in PASI compared with baseline. However, the decision model requires the *mean* absolute or percentage change in PASI as an input parameter, given each type of biologic therapy and no therapy.

This appendix describes how the mean absolute change in PASI is calculated in the decision model.

Methods

We calculate the marginal probabilities of each mutually exclusive outcome:

$$\Pr(\% \Delta \text{PASI} < 49) = 1 - \Pr(\text{PASI } 50)$$

$$\Pr(50 < \% \Delta \text{PASI} < 74) = \Pr(\text{PASI } 50) - \Pr(\text{PASI } 75)$$

$$\Pr(75 < \% \Delta \text{PASI} < 89) = \Pr(\text{PASI } 75) - \Pr(\text{PASI } 90)$$

$$\Pr(90 < \% \Delta \text{PASI}) = \Pr(\text{PASI } 90)$$

Figure 11 shows a segment of the decision tree for the psoriasis response and non-response for a given drug. $\Pr(< \text{PASI } 50 | < \text{PASI } 75)$ indicates the probability of a change in PASI of between 0% and 49%, given improvement of less than PASI 75, and is calculated as:

$$\Pr(< \text{PASI } 50 | < \text{PASI } 75) = \Pr(\% \Delta \text{PASI} < 49) / [1 - \Pr(\text{PASI } 75)]$$

We know that the improvement for this group is within the range 0%–50%, and in the base case we (conservatively) assume that the relative improvement in PASI for this group is 0. For change

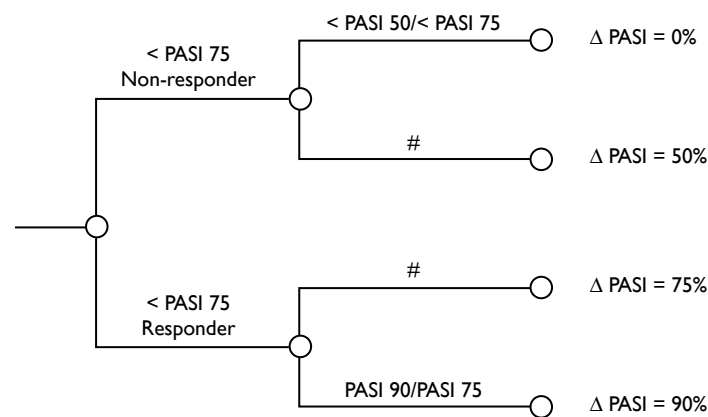

FIGURE 11 Segment of decision tree showing the mean change in PASI for psoriasis response and psoriasis non-response.

in PASI between 50% and 74%, we assume the change is 50%. For a change between 75% and 89%, we assume the change is 75%, and between 90% and 100%, we assume the change is 90%.

Consequently, if baseline absolute PASI is P_0 , the mean absolute change in PASI for those achieving a PASI 75 response (while on therapy) is:

$$E(\Delta \text{PASI} | \text{PASI } 75) = P_0 \times [0.75 \times \Pr(75 < \% \Delta \text{PASI} < 89) + 0.9 \times \Pr(\text{PASI } 90)] / \Pr(\text{PASI } 75)$$

The mean absolute change in PASI for those not achieving a PASI 75 response (while on biologic therapy) is:

$$E(\Delta \text{PASI} | < \text{PASI } 75) = P_0 \times [0 \times \Pr(\% \Delta \text{PASI} < 49) + 0.5 \times \Pr(50 < \% \Delta \text{PASI} < 74)] / [1 - \Pr(\text{PASI } 75)]$$

Conditioning the change in PASI on PASI 75 allows the consequences to be explored of using different decision rules about whether to withdraw biologic therapy or not if a PASI 75 response is not achieved, or to withdraw if a PASI 75 response is achieved, but a PsARC response is not.

Sensitivity analysis

Simple sensitivity analyses will assume different values of the thresholds for the change in PASI, such as using the upper end of the range, or the mid-point. For example, for PASI response between 50% and 74%, we could assume that the change is 74% or 57% (the mid-point). Note that, a priori, we have no reason to expect the distribution of percentage changes in PASI within a given range to be uniformly distributed within that range, and so we have no reason to expect the mid-point to better estimate the mean change than other values.

An alternative sensitivity analysis is suggested by data from the Abbott submission.¹⁵¹ Abbott¹⁵¹ used regression to estimate the relationship between PASI response and the mean absolute change in PASI. Their results are reproduced in *Table 75*.

TABLE 75 Psoriasis Area and Severity Index at 12 weeks, dependent on patient demographics and type of response (Table A2.3 in Abbott.¹⁵¹ Reproduced with permission from Abbott Laboratories Ltd.)

Description	Covariate	Parameter estimate	SE	t-value	Pr > t
Intercept	α	0.36879	0.28977	1.27	0.212
Baseline PASI _t	β_1	1.01496	0.08344	12.16	<0.0001
Baseline age	β_2	-0.00461	0.00541	-0.85	0.3997
Gender (1 = male)	β_3	0.08901	0.10511	0.85	0.4032
Baseline PsA duration	β_4	0.00075643	0.00666	0.11	0.9103
Whether on MTX (1 = yes)	β_5	0.00433	0.10234	0.04	0.9665
Whether a PASI 50–75 responder	β_6	-0.85124	0.16655	-5.11	<0.0001
Whether a PASI 75–90 responder	β_7	-1.13011	0.15625	-7.23	<0.0001
Whether a PASI 90+ responder	β_8	-1.89522	0.18899	-10.03	<0.0001
Treatment = biologic	β_9	-0.50235	0.12880	-3.90	0.0004

PASI_t = transformed PASI = Log(PASI + 0.5).

$PASI_{12} = \alpha + \beta_1 PASI_0 + \beta_2 age_0 + \beta_3 gender + \beta_4 duration_0 + \beta_5 MTX + \beta_6 PASI\ 50-75_{12} + \beta_7 PASI\ 75-90_{12} + \beta_8 PASI\ 90+_{12} + \beta_9 treatment.$

TABLE 76 Predicted probabilities of psoriasis response and proportionate change in PASI for responders and non-responders

	Etanercept	Infliximab	Adalimumab	Placebo
Pr(PASI 50)	0.40	0.91	0.74	0.13
Pr(PASI 75)	0.18	0.77	0.48	0.04
Pr(PASI 90)	0.07	0.56	0.26	0.02
Percentage change in PASI for PASI 75 non-responders	13.70	31.10	24.00	NA ^a
Percentage change in PASI for PASI 75 responders	81.20	85.90	83.10	80.60

NA, not available.

a The change in PASI for non-responders on placebo is not used in the decision model.

Results

Table 75 illustrates the calculation of the change in PASI for responders and non-responders using the probabilities of psoriasis response given in Chapter 3 (see *Results of review of clinical effectiveness*) and the assumptions in the methods section above. For convenience, these probabilities are shown again in Table 76.

Conclusion

On average, infliximab is predicted to give the greatest probability of a psoriasis response and the greatest change in PASI in both responders and non-responders. Adalimumab is the second-most effective and etanercept is predicted to be the least effective in terms of psoriasis.

Appendix 19

All-cause mortality

Introduction

All-cause mortality rates for a given age are higher in people with PsA than the general population. Wong *et al.*²⁹ found that men attending a PsA clinic have a 65% greater mortality rate than the general population in Canada and women 59% greater mortality. A UK population-based study using the General Practice Research Database found 50% greater mortality in patients with severe psoriasis than the general population and no change in this standardised mortality ratio after excluding patients with PsA, indicating that patients with PsA have similar mortality risk to those with severe psoriasis.²³⁹ However, there is no clear evidence that biologic therapies change these mortality risks.

Published life tables give mortality risks in the general population for a given age and gender. However, it has been shown that in developed countries, all-cause mortality hazards increase at an exponential rate after the age of 40 years, and a Gompertz function closely approximates these hazards.²⁴⁰ Using a parametric function instead of looking up the hazards directly from life tables requires fewer parameters in the decision model and arguably saves computation time. Furthermore, a parametric hazard function might allow more accurate interpolation of the hazards between years if the cycle length of the model is < 1 year.

This paper describes the estimation of the Gompertz function to predict all-cause mortality hazards.

Methods

In the Gompertz function, mortality hazards $h(x)$ at age x (where $x \geq 40$) are:

$$h(x) = R \exp(a x), \text{ where } R \text{ and } a \text{ are parameters.}$$

Taking log:

$$\log[h(x)] = \log(R) + a x$$

This linear relationship is straightforward to estimate from life-table hazards using ordinary least-squares regression of log-hazards versus age. These hazards can be adjusted for the PsA population by multiplying by the standardised mortality ratio for the disease.

Results

The results of the regression of log(life-table hazards) versus age in years are shown in *Table 77* for the general population in men and women for the years 2006–8.

TABLE 77 Results of regression of log(life-table hazards) versus age in years in the general population aged ≥ 40 years

	Mean coefficient	SE	95% CI
Men			
Age	0.0946	0.00067	0.0932 to 0.0959
Constant (log R)	-10.2570	0.04600	-10.3490 to -10.1650
Adj R -squared	0.9965		
Women			
Age	0.1010	0.00067	0.0999 to 0.1027
Constant (log R)	-11.1090	0.04600	-11.2030 to -11.0170
Adj R -squared	0.9969		

Conclusion

The Gompertz function can estimate general population life table all-cause hazards with a high degree of precision.

Appendix 20

Sequential use of biologic therapy

Introduction

The base-case decision model assumes that patients who enter the model are 'biologic naive', and that those who fail therapy have no further options, and, consequently, receive palliative care only. In practice, many patients who withdraw from their first biologic agent will switch to another.²⁴¹ It is potentially important that the decision model takes account of this option. Hence the model was extended to consider, as far as available evidence allows, the cost-effectiveness of sequential use biologics in patients who have failed on earlier biologic therapy.

This appendix describes the literature search and methods used to obtain the response and withdrawal parameters to undertake this modelling. The results of the cost-effectiveness analysis in the subgroup of patients who switch to another biologic drug are presented in *Chapter 4* (see *York Economic Assessment*).

Methods

The approach taken here is to consider the effectiveness and cost-effectiveness of alternative strategies for a subgroup of patients who have failed a first course of biologic therapy. For example, if etanercept had been tried and failed, the choice would be between a second trial with adalimumab or infliximab, or no further biologic therapy.

The reason why the patient failed the first course of therapy is potentially important information in deciding on the second course. Therefore, we consider two subgroups: (1) patients who has failed etanercept because of adverse events; and (2) those who failed because of lack of efficacy. We do not make a distinction here between those who had complete lack of response (measured by PsARC at 3 months) and those who had secondary loss of treatment efficacy.

We search the clinical literature and publications from UK and other registers to find response and/or withdrawal rates from a second drug for patients in PsA or RA who failed a first drug because of lack of efficacy or adverse events.

The base-case decision model has two measures of initial response (PASI 75 for psoriasis and PsARC for arthritis) and an estimated rate of withdrawal after the first 3 months. Some of the clinical literature report RRs (such as HRs) of failing a second biologic drug, compared to failing a first drug. We assume the odds of PsARC for a drug used as second-line therapy are equal to the odds as first therapy (estimated by the evidence synthesis in *Chapter 3*), multiplied by the RR for failing second therapy versus first therapy. We make a similar assumption to estimate the hazards of withdrawal after 3 months for a second course of biologic therapy. Given that in the base-case model patients are not withdrawn for failing to obtain PASI 75, we assume that the probabilities of PASI 75 in the second course of therapy are the same as in the first course. All of the other parameters of the model are the same as in the base case.

Results of the literature search

A review the literature did not find any RCTs that had studied these subgroups. However, the review of publications from biologics registers found four papers that included some relevant information about second-course biologic therapies.

Table 78 shows the results of three papers that estimated the probabilities of remaining on therapy ('persistence') in patients with PsA for first and second courses of biologic drugs. In

TABLE 78 Probabilities of persistence up to 1 year or rates of withdrawal with first biologic drug and second biologic drug^a

Course of treatment	No. starting	No. failed	Percentage failed	Reason failed	Pr survival 1-year
<i>Coates 2008,²⁴¹ UK, patients with PsA</i>					
First	60	14	23	All reasons	NA
Second	12	7	58	All reasons	NA
<i>Saad 2009,¹⁹¹ UK, patients with PsA</i>					
First	566	NA		All reasons	0.82 (0.79 to 0.85)
Second	178	NA		All reasons	0.74 (0.71 to 0.78)
First	566	NA		Inefficacy	0.92 (0.89 to 0.94)
Second	178	NA		Inefficacy	0.70 (0.63 to 0.75)
First	566	NA		Adverse events	0.96 (0.94 to 0.97)
Second	178	NA		Adverse events	0.76 (0.69 to 0.81)
<i>Gomez-Reino 2006,²²⁸ Spain, patients with PsA</i>					
First	289	55	19	All reasons	0.87 (0.83 to 0.9)
Second	15	8	53	All reasons	0.81 (0.65 to 0.9)
<i>Gomez-Reino 2006,²²⁸ Spain, all chronic arthritis patients</i>					
Course of treatment			Reason failed		Rate of failure per 100 patient-years treated
First, infliximab			Adverse events		6.5
First, infliximab			Inefficacy		4.7
Second, infliximab			Adverse events		32.7
Second, infliximab			Inefficacy		38.5
First, etanercept			Adverse events		3.8
First, etanercept			Inefficacy		3.6
Second, etanercept			Adverse events		6.1
Second, etanercept			Inefficacy		9.3
First, adalimumab			Adverse events		7.2
First, adalimumab			Inefficacy		3.2
Second, adalimumab			Adverse events		12.5
Second, adalimumab			Inefficacy		12.5

NA, not available.

a The reason for withdrawal is shown if given in the paper.

all of the studies the probability of persistence up to 1 year is lower for second biologic than first biologic. These papers did not report withdrawal for second biologic conditional on the reason for withdrawal from the first biologic. Gomez-Reino *et al.*²²⁸ also estimated the rates of withdrawal for adverse events and inefficacy for each biologic. These data show that in all of the biologic therapies at first course, patients tended to be more likely to withdraw for adverse events than inefficacy. Rates of withdrawal from infliximab when used as second-line therapy tend to be higher than other drugs used as second-line therapy. However, SEs are not reported so this may be due to chance. Perhaps more importantly, these are not randomised data and patients cohorts are unlikely to be similar between the drugs.

Table 79 shows the result of one paper that reported HRs for withdrawal from second course of therapy compared with the first course of therapy.¹⁹⁶ The paper distinguishes between outcomes for patients who start a second course of biologics after adverse events in the first course, and patients who start a second course of biologics following lack of efficacy in the first course. The data are for patients with RA, rather than PsA, and are from patients in the UK BSR register who had at least 6 months' follow-up by the end of April 2005.

TABLE 79 HRs for withdrawal from second course of therapy compared with the first course of therapy^a

Course of treatment	<i>n</i> starting	No. failed	Percentage failed	Reason failed	HR for discontinuation of second therapy, compared with rate for first therapy ^b
First	6739	2360	35	All reasons	
First	6739	841	12	Inefficacy	
First	6739	1023	15	Adverse events	
First	6739	496	7	Other reason	
Second inefficacy in first	503	78	16	Inefficacy	2.7 (2.1 to 3.4)
Second adverse event in first	353	33	9	Inefficacy	1.2 (0.8 to 1.6)
Second inefficacy in first	503	50	10	Adverse events	1.1 (0.9 to 1.5)
Second adverse event in first	353	71	20	Adverse events	2.3 (1.9 to 2.9)

a Source: Hyrich *et al.*¹⁹⁶

b Mean (95% CI).

TABLE 80 Parameters to estimate in the decision model for switching biologics

		Reason for discontinuation of first course of biologic therapy	
		Inefficacy	Adverse event
Reason for discontinuation of second course of biologic therapy	Initial PsARC response (at 3 months), by drug <i>j</i>	p.psarcj2 (first inefficacy)	p.psarcj2 (first adverse event)
	Rate of secondary non-response or adverse event after 3 months	p.long2 (first inefficacy)	p.long2 (first adverse event)

Parameters in the decision model

There are four sets of parameters to estimate to implement the model for switching biologic therapy (*Table 80*). We assume the HRs for failing a second biologic compared with failing the first biologic are the same for all biologics.

Initial Psoriatic Arthritis Response Criteria response given patient discontinued first course because of a lack of efficacy

Based on the data in *Table 79*, we assume that if the first biologic agent was discontinued due to inefficacy, the odds of achieving a PsARC response in the first 3 months on the second agent was reduced on average 2.7-fold (95% CI 2.1 to 3.4). Therefore, if the odds of a PsARC response at 3 months in drug j used as first biologic are $o.psarc_{j1} = p.psarc_{j1} / (1 - p.psarc_{j1})$ then the odds of a PsARC response at 3 months in drug j used as second biologic given the first was discontinued for lack of efficacy are:

$$o.psarc_{j2}(\text{first inefficacy}) = o.psarc_{j1} / 2.7$$

Initial Psoriatic Arthritis Response Criteria response given patient discontinued first course because of an adverse event

The probability of an initial PsARC response for the second agent, given the first was discontinued for an adverse event is unchanged, so:

$$o.psarc_{j2}(\text{first adverse event}) = o.psarc_{j1}$$

Withdrawal after first 3-month trial period given patient discontinued first course because of a lack of efficacy

Based on the data in *Table 79*, we assume that if the first biologic agent was discontinued due to inefficacy, the risk of withdrawal after 3 months due to inefficacy was increased 2.7-fold. However, the odds of withdrawal due to adverse events was unchanged, given the 95% CI includes 1.

In *Table 79*, 6739 patients started a first biologic. Of these, 2360 patients withdrew – 841 (36%) for inefficacy and 1023 (43%) for adverse events. If the rate of withdrawal after 3 months from the first biologic agent for any reason is ‘ $p.long_1$ ’ then the rate of withdrawal from the first biologic agent for inefficacy is: $p.long_1 \times 0.36$. We assume that the rate of withdrawal after 3 months for the second agent, given the first was discontinued for lack of efficacy, is:

$$p.long_2(\text{first inefficacy}) = p.long_1 \times 0.36 \times 2.7 + p.long_1 \times 0.43 + p.long_1 \times 0.21$$

Withdrawal after first 3-month trial period given patient discontinued first course because of an adverse event

Given the data in *Table 79*, we assume that if the first biologic agent was discontinued due to adverse events, the risk of withdrawal from the second biologic due to adverse events was increased by 2.3 (95% CI 1.9 to 2.9). The overall expected rate of withdrawal after 3 months for the second agent, given the first was discontinued for an adverse event is:

$$p.long_2(\text{first adverse event}) = p.long_1 \times 0.36 + p.long_1 \times 0.43 \times 2.3 + p.long_1 \times 0.21$$

The HRs in *Table 79* will be entered into the model as probability distributions. The HR on a log-scale for continuing lack of efficacy has a mean of 0.993 (SE 0.120), and the HR on a log-scale for continuing adverse events has mean of 0.832 (SE 0.106).

Conclusions

This subgroup analysis is necessarily exploratory, given the limitations of the data for outcomes after switching biologic therapies. These limitations include:

- The data on outcomes after switching comes from patients with RA not PsA. Data of withdrawal by type of disease suggest that there may be differences in withdrawal rates between RA and PsA.^{226,242} However, the data on outcomes after switching from patients with PsA were not reported in sufficient detail for the decision model. We assume in the decision model that even if there are differences in absolute withdrawal rates between RA and PsA, the HRs comparing withdrawal from first-line therapy with second-line therapy do not differ by disease.
- The data are from observational studies. Therefore, there is the possibility of selection bias and other confounding factors. However, Hyrich *et al.*¹⁹⁶ cautions that designing a randomised experiment for patients to receive a second agent on the basis of their outcome (inefficacy or toxicity) would present considerable practical and ethical difficulties. Therefore, observational studies may be the best data that can be obtained.

The data cannot differentiate between those who had complete lack of response (such as PsARC at 3 months) and those who had secondary loss of treatment efficacy. The decision model has therefore assumed the HRs apply equally to both types of response.

Appendix 21

R programme for the York economic analysis

```
#####David Epstein,
University of York
#31 July 2009
#Programme written for R version 2.6.1
#Copyright © 2007 The R Foundation for Statistical Computing
#Basic model without sequences
#Psoriatic Arthritis
#####
#remove just about everything from the working environment
rm(list=ls())#a 'clear-all' statement
options(show.error.messages = TRUE)
set.seed(1001)
#detach all data tables etc
if("tab.dat1"%in% search())detach(tab.dat1)
if("tab.dat2"%in% search())detach(tab.dat2)
if("tab1"%in% search())detach(tab1)
if("tab2"%in% search())detach(tab2)

setwd("z:/dme2/psa/rcode")
tab.dat1<-read.csv("data1.csv",header=TRUE)#data input, see Table 33 in Chapter 4, York
Economic Assessment
tab.dat2<-read.csv("data2.csv",header=TRUE)#data input, see Table 33 in Chapter 4, York
Economic Assessment
#sa<-1 #basecase
#deter<-1 #deterministic
#Years <-40 #duration of treatment effect
#####model
model<-function(sa, deter, Years){

#functions
b.beta<-function(p,var.p){(1-p)*(1-p)*p/var.p}#beta parameter of beta dist
a.beta<-function(p,var.p){p*p*(1-p)/var.p}#alpha parameter of beta dist

a.gamma<-function(m,var.m){m*m/var.m}#shape parameter of gamma dist
s.gamma<-function(m,var.m){var.m/m}#scale parameter of gamma dist

sens.a<-function(t1,q,var){#qth point on normal distribution
#var is variable name in string format
t1[,var]<-qnorm(q,t1[,var],t1[,paste(var,"_SE",sep="")])
return(t1)}

c.pasi<-0 #linear costs of PASI (sensitivity analysis)
#####sensitivity analyses, 1= basecase
if (sa==1){#basecase
```

```

tab1<-tab.dat1
tab2<-tab.dat2
}
if (sa==2) {# rebound less than initial gain, instead as estimated by expert elicitation
tab1<-tab.dat1
tab1$loss.w<- -0.62
tab2<-tab.dat2
}
if (sa==3) {#high haq progression in natural history & after withdrawal
tab1<-sens.a(tab.dat1,0.975,"HAQ1.w")
tab2<-tab.dat2
}
if (sa==4) {#utility function, Abbott
tab1<-tab.dat1
tab2<-tab.dat2
tab1$hhaq<- -0.295 #coefficient on haq
tab1$hhaq_SE<-0.0189
tab1$hpasi<- -0.0355 #coefficient on log_pasi
tab1$hpasi_SE<-0.0096
}
if (sa==5) {#no correlation psarc + pasi
tab1<-tab.dat1
tab2<-tab.dat2
tab2$rho<-c(0,0,0)}

if (sa==6) {#no adjustment for plac effect
tab1<-tab.dat1
tab2<-tab.dat2
tab1$plac.effect<-2}

if (sa==7) {#continue only if both psarc & pasi75 & baseline pasi HI
tab1<-tab.dat1
tab2<-tab.dat2
tab1$PASI0<-12.5
tab1$c2.1<-566
tab1$c2.1_SE<-25
tab1$continue<-2}

if (sa==8) {#continue if either response & baseline pasi HI
tab1<-tab.dat1
tab2<-tab.dat2
tab1$PASI0<-12.5
tab1$c2.1<-566
tab1$c2.1_SE<-25
tab1$continue<-4}

if (sa==9) {#Abbott cost -HAQ function, standard errors not used
tab1<-tab.dat1
tab2<-tab.dat2
tab1$alpha<-54.1
tab1$beta<-1.237
}

```

```
if (sa==10) {#baseline HAQ
tab1<-tab.dat1
tab2<-tab.dat2
tab1$HAQ0<-1.8
}

if (sa==11) {#baseline PASI HI
tab1<-tab.dat1
tab2<-tab.dat2
tab1$PASI0<-12.5
tab1$c2.1<-566
tab1$c2.1_SE<-25
}

if (sa==12) {#annual inpatient therapy for mild to mod psoriasis instead of UVB
tab1<-tab.dat1
tab2<-tab.dat2
tab1$c2.1<-(7176+2*79)/4
}

if (sa==13) {#cost-HAQ as Michaud US data
tab1<-tab.dat1
tab2<-tab.dat2
tab1$c1 <-189
tab1$c1_SE <-21
}

if (sa==14){#utility function haq-Wyeth
tab1<-tab.dat1
tab2<-tab.dat2
tab1$h1<- -0.455
tab1$h1_SE <-0.027
tab1$h2<-0 #no pasi effect on utility
tab1$h3<-0 #no pasi*haq interaction
}

if (sa==15){#haq progress while on drug
tab1<-sens.a(tab.dat1,0.025,"HAQ1.d")
tab2<-tab.dat2
}

if (sa==16){#withdrawal hi
tab1<-sens.a(tab.dat1,0.975,"ln.long.yr")
tab2<-tab.dat2
}
if (sa==17){#withdrawal low
tab1<-sens.a(tab.dat1,0.025,"ln.long.yr")
tab2<-tab.dat2
}

if (sa==18){#all treatments have equal effectiveness psarc
tab1<-tab.dat1
```

```

tab2<-tab.dat2
tab2$p.psarc<-tab2$p.psarc[2]
tab2$p.psarc_SE<-tab2$p.psarc_SE[2]

}
if (sa==19){#all treatments have equal effectiveness pasi50,75,90
tab1<-tab.dat1
tab2<-tab.dat2
tab2$p.pasi.50<-tab2$p.pasi.50[2]
tab2$p.pasi.75<-tab2$p.pasi.75[2]
tab2$p.pasi.90<-tab2$p.pasi.90[2]
tab2$p.pasi.50_SE<-tab2$p.pasi.50_SE[2]
tab2$p.pasi.75_SE<-tab2$p.pasi.75_SE[2]
tab2$p.pasi.90_SE<-tab2$p.pasi.90_SE[2]
}

if (sa==20){#costs of drugs, Wyeth submission
tab1<-tab.dat1
tab2<-tab.dat2
tab2$c.drug1<-c(2282,6286,2282)
tab2$c.drug2<-c(2178,3201,2178)
tab2$c.drug3<-c(2162,3184,2162)
}

if (sa==21){#severe psoriasis with hi costs psoriasis
tab1<-tab.dat1
tab2<-tab.dat2
tab1$PASI0<-12.5
tab1$c2.1<-2133#3month cost of inpatient therapy
tab1$c2.1_SE<-93
}

if (sa==22){#mean change in HAQ same for all psarc responders
tab1<-tab.dat1
tab2<-tab.dat2
tab2$HAQ.no.resp<- -0.1697
tab2$HAQ.no.resp_SE<-0.03382
tab2$HAQ.resp<- -0.5688
tab2$HAQ.resp_SE<-0.03148
tab1$HAQ.resp.plac<- -0.260
tab1$HAQ.resp.plac_SE<- 0.0277
}
if (sa==23){#costs of drugs, 3 vials infliximab
tab1<-tab.dat1
tab2<-tab.dat2
tab2$c.drug1[2]<-4264
tab2$c.drug2[2]<-2809
tab2$c.drug3[2]<-2283
}
if (sa==24){#second biologic, if failed previous biologic for inefficacy
tab1<-tab.dat1
tab2<-tab.dat2

```

```

tab1$ln.inef<-0.993#log HR of failure for inefficacy in 2nd drug | inefficacy in 1st drug
tab1$ln.inef_SE<-0.120
tab1$p.inef<- 841/2360#% who failed first drug for inefficacy
tab1$p.ae<-1023/2360#% who failed 1st for AE
}
if (sa==25){#second biologic, if failed previous biologic for AE
tab1<-tab.dat1
tab2<-tab.dat2
tab1$ln.AE<-0.832#log HR of failure for AE in 2nd drug | AE in 1st drug
tab1$ln.AE_SE<-0.106
tab1$p.inef<- 841/2360#% who failed first drug for inefficacy
tab1$p.AE<-1023/2360#% who failed 1st for AE
}
if (sa==26) {# rebound to natural history
tab1<-tab.dat1
tab1$loss.w<- 3 #HAQ after withdrawal will be back to natural history line
tab2<-tab.dat2}

if (sa==27){#costs of drugs, =0, psoriasis = 0
tab1<-tab.dat1
tab2<-tab.dat2
tab2$c.drug1<-0
tab2$c.drug2<-0
tab2$c.drug3<-0
tab1$c2.1<-0
tab1$c2.2<-0
tab1$h2<-0

}

if (sa==28){#costs of psoriasis<-0, HAQ = 0
tab1<-tab.dat1
tab2<-tab.dat2
tab1$c2.1<-0
tab1$c2.2<-0
tab1$c1<-0
tab1$c0<-0

tab1$h1<-0
tab1$h2<-0
}
if (sa==29){#costs haq 0, drugs =0
tab1<-tab.dat1
tab2<-tab.dat2
tab1$c1<-0
tab1$c0<-0
tab2$c.drug1<-0
tab2$c.drug2<-0
tab2$c.drug3<-0
tab1$h1<-0

}

```

```

if (sa==30){#no psoriasis
tab1<-tab.dat1
tab2<-tab.dat2
tab1$PASI0<-0
tab1$c2.1<-0
tab1$c2.2<-0
tab1$h2<-0
}
if (sa==31){#no psoriasis costs
tab1<-tab.dat1
tab2<-tab.dat2
tab1$c2.1<-0
tab1$c2.2<-0
}
if (sa==32){#low linear psoriasis costs (SP)
tab1<-tab.dat1
tab2<-tab.dat2
tab1$c2.1<-0
tab1$c2.2<-0
c.pasi<-53
}
if (sa==33){#high linear psoriasis costs (SP)
tab1<-tab.dat1
tab2<-tab.dat2
tab1$c2.1<-0
tab1$c2.2<-0
c.pasi<-167
}
if (sa==34){#high withdrawal
tab1<-tab.dat1
tab2<-tab.dat2
tab1$ln.long.yr<-log(0.11)
}

#deterministic = 1, probabilistic = 2
if (deter ==1){}
if (deter ==2) {

#####Monte Carlo simulation
attach(tab1)
attach(tab2)
#tab1$h0[1]<-rnorm(1,h0[1],h0_SE[1])#amend? use cholesky
tab1$h1[1]<-rnorm(1,h1[1],h1_SE[1])#utility function
tab1$h2[1]<-rnorm(1,h2[1],h2_SE[1])
tab1$h3[1]<-rnorm(1,h3[1],h3_SE[1])
if (sa==4){#Abbott utility function
tab1$hhaq<- rnorm(1,hhaq,hhaq_SE)
tab1$hpasi<- rnorm(1,hpasi,hpasi_SE)}
tab1$c1[1]<-rnorm(1,c1[1],c1_SE[1])#cost as function of HAQ
if (!(sa==30|sa==31|sa==32|sa==33)){
tab1$c2.1[1]<-rnorm(1,c2.1[1],c2.1_SE[1])#cost with hospital trt for skin
tab1$c2.2[1]<-rnorm(1,c2.2[1],c2.2_SE[1])#cost with controlled skin
}
}

```

```

tab1$HAQ1.d<-rnorm(1,HAQ1.d[1],HAQ1.d_SE[1])#HAQ progression on drug
#HAQ1.w is difficult to parameterise/results are non linear in changesi n this parameter
mn<-HAQ1.w#from NOAR
var<-(HAQ1.w_SE^2)
tab1$HAQ1.w<-rgamma(1,shape=a.gamma(mn,var),scale=s.gamma(mn,var))#HAQ progression
off drug
#Loss is bounded by the initial gain, so is non-symmetric. Difficult to parameterise for prob sa
tab1$loss.w[1]<-rnorm(1,loss.w[1],loss.w_SE[1])#rebound
tab1$ln.R.g.m[1]<-rnorm(1,ln.R.g.m[1],ln.R.g_SE[1])#Gompertz male
tab1$a.g.m[1]<-rnorm(1,a.g.m[1],a.g_SE[1])
tab1$ln.R.g.f[1]<-rnorm(1,ln.R.g.f[1],ln.R.g_SE[1])#Gompertz female
tab1$a.g.f[1]<-rnorm(1,a.g.f[1],a.g_SE[1])
tab1$ln.long.yr[1]<-rnorm(1,ln.long.yr[1],ln.long.yr_SE[1])#long term withdrawal rate
tab1$HAQ.resp.plac<-rnorm(1,HAQ.resp.plac,HAQ.resp.plac_SE)
if (sa==24) {tab1$ln.inef<-rnorm(1,ln.inef,ln.inef_SE)}
if (sa==25) {tab1$ln.AE<-rnorm(1,ln.AE,ln.AE_SE)}

mn<-p.psarc.plac[1]
var<-p.psarc.plac_SE[1]^2
tab1$p.psarc.plac[1]<-rbeta(1,a.beta(mn,var),b.beta(mn,var))#psarc placebo
mn<-p.pasi.50.plac[1]
var<-p.pasi.50.plac_SE[1]^2
tab1$p.pasi.50.plac[1]<-rbeta(1,a.beta(mn,var),b.beta(mn,var))#
mn<-p.pasi.75.plac[1]
var<-p.pasi.75.plac_SE[1]^2
tab1$p.pasi.75.plac[1]<-rbeta(1,a.beta(mn,var),b.beta(mn,var))#
mn<-p.pasi.90.plac[1]
var<-p.pasi.90.plac_SE[1]^2
tab1$p.pasi.90.plac[1]<-rbeta(1,a.beta(mn,var),b.beta(mn,var))#
mn<-p.psarc[1:3]
var<-p.psarc_SE[1:3]^2
tab2$p.psarc[1:3]<-rbeta(3,a.beta(mn,var),b.beta(mn,var))
mn<-p.pasi.50[1:3]
var<-p.pasi.50_SE[1:3]^2
tab2$p.pasi.50[1:3]<-rbeta(3,a.beta(mn,var),b.beta(mn,var))#trt response

mn<-p.pasi.75[1:3]
var<-p.pasi.75_SE[1:3]^2
tab2$p.pasi.75[1:3]<-rbeta(3,a.beta(mn,var),b.beta(mn,var))#trt response
mn<-p.pasi.90[1:3]
var<-p.pasi.90_SE[1:3]^2
tab2$p.pasi.90[1:3]<-rbeta(3,a.beta(mn,var),b.beta(mn,var))#trt response

tab2$HAQ.no.resp[1:3]<-rnorm(3,HAQ.no.resp,HAQ.no.resp_SE)#these may have to be
constructed from elemental data
tab2$HAQ.resp[1:3]<-rnorm(3,HAQ.resp,HAQ.resp_SE)
tab2$rho[1:3]<-rnorm(3,rho,rho_SE)#correlation PASI 75 & PsARC
detach(tab1)
detach(tab2)

}# end if

```

```

t0<-proc.time()
attach(tab1)
attach(tab2)

#####functions
#Gompertz hazard for all cause mortality.
#Probability of death during 3month period t+dt given survival up to cycle t
#This could be done by looking up from life tables, but the Gompertz gives a
#very good parametric fit to life table hazards, and requires fewer parameter inputs
p.m<-function(t) {smr*R.g*exp(a.g.1*((t-1)/4+Age))/4}
disc<-function(t){(1+r)^(-(t-1)/4)}#discount rate
#HAQ and PASI are clinical scoring systems for arthritis and skin respectively
#, a higher value of either is a worse health state
if (sa!=4) EQ5D<-function(HAQ,PASI){h0+h1*HAQ+h2*PASI+h3*HAQ*PASI}#EQ5D utility
given HAQ
if (sa==4) EQ5D<-function(HAQ,PASI){h0+hhaq*HAQ+hpasi*log(PASI+0.5)}# Abbott utility
if (sa!=9) c.HAQ<-function(HAQ){c0+c1*HAQ}#costs given HAQ
if (sa==9) c.HAQ<-function(HAQ){alpha*exp(beta*HAQ)}#costs given HAQ, Abbott
HAQ.w1<-function(t){HAQ.d(W)+rebound(W)+HAQ1.w*(t-W)}#HAQ at time t after time of
withdrawal W(t>=W)
HAQ.w2<-function(t){ifelse(HAQ.w1(t)<3,ifelse(HAQ.w1(t)>0,HAQ.w1(t),0),3)}
HAQ.w<-function(t){ifelse(t>=W,HAQ.w2(t),NA)}
HAQ.d1<-function(t){HAQ0+HAQ1.d*(t-1)}#HAQ while on drug (but not counting initial gain,
this is added later)
HAQ.d<-function(t){ifelse(HAQ.d1(t)<3,ifelse(HAQ.d1(t)>0,HAQ.d1(t),0),3)}

#Parameter 'loss' is the absolute rebound in HAQ after withdrawal, relative to baseline HAQ
#If loss>=0 then this is rebound at least to initial gain ie:baseline HAQ0 <= Loss <= natural
history
#Loss can also be negative, meaning that the HAQ loss on withdrawal is less than the HAQ initial
gain
#ie maintain some of the inital gain in the long term after withdrawal
#If loss = 3 then this is rebound in HAQ to 'natural history ie what it would have been if no
antiTNF had been given
rebound<-function(t){ifelse((HAQ1.w-HAQ1.d)*(t-1)>loss,loss,(HAQ1.w-HAQ1.d)*(t-1))}#loss
of 0 is rebound to initial gain
#HAQ,if never started on drug (natural history)
HAQ.never1<-function(t){HAQ0+HAQ1.w*(t-1)}
HAQ.never<-function(t){ifelse(HAQ.never1(t)<3,ifelse(HAQ.never1(t)>0,HAQ.never1(t),0),3)}
Mn.logn<-function(mu,se){exp(mu+0.5*se^2)}#Mean(X) if X = exp(Y) and Y~normal(mu,se)
Var.logn<-function(mu,se){(exp(se^2)-1)*exp(2*mu+se^2)}#Var(X) if X=exp(Y) and
Y~normal(mu,se)
Mn.Pr<-function(odds){exp(odds)/(1+exp(odds))}#probability given odds
#Delta method: Second order Taylor expansion to approximate variance of probability
(Wikipedia: «Variance»)
Var.Pr<-function(odds,var.odds){((odds/((1+odds)^2))^2)*var.odds}#variance of probability
given odds
#####Parameter assignment

#parameters (constants)
smr<-ifelse(Male==1,SMRmen,SMRwomen)
#T= number of cycles, each cycle is 3months

```

```

T <- Years*4
#All cause survival (only valid for Age > 40)
R.g<- exp(ifelse(Male==1,ln.R.g.m[1],ln.R.g.f[1]))
a.g.1<-ifelse(Male==1,a.g.m,a.g.f) #parameter of Gompertz function
#3 drugs, A E I
#5 types of response in short term
#(1=response skin only,2= response joints only
#, 3= response both, 4 = no response, 5 = adverse effect)

#long term fail rate
#p.long might also depend on whether first or second line, and reason for previous failure
#Expressed as 3m rate of withdrawal, in Bravo Vergel was 0.113
rate.long<-Mn.logn(ln.long.yr,ln.long.yr_SE)#annual withdrawal rate
if (sa ==24){#2nd course of biologics given inefficacy in first course
rate.long<-rate.long*p.inef*exp(ln.inef)+rate.long*(1-p.inef)}
if (sa ==25){#2nd course of biologics given AE in first course
rate.long<-rate.long*p.AE*exp(ln.AE)+rate.long*(1-p.AE)}

p.long<-rep(1-exp(-rate.long/4),3)#lognormal
#response to drug in first 12 weeks after trial
#Here we must make assumptions about the joint probability of skin and arthritis response
#Some data from ADEPT trial, otherwise assume independence of response types

#Rebound
#Loss is a parameter representing the expert opinion of the change in HAQ after withdrawal from
drug compared with initial gain
loss<-max(c(loss.w,HAQ.resp))#HAQ |response is negative for all drugs.
#Therefore «loss» can take values from HAQ.resp (< 0, represents no change) to 3 (natural
history).
#Zero represents return to the initial baseline HAQ0

#PASI responses
p.pasi.0.49.plac<- 1-p.pasi.50.plac
p.pasi.50.70.plac<-p.pasi.50.plac-p.pasi.75.plac
p.pasi.75.89.plac<-p.pasi.75.plac-p.pasi.90.plac
p.pasi.90.100.plac<-p.pasi.90.plac

p.pasi.0.49<- 1-p.pasi.50
p.pasi.50.74<-p.pasi.50-p.pasi.75
p.pasi.75.89<-p.pasi.75-p.pasi.90
p.pasi.90.100<-p.pasi.90
#rho = correlation between pasi75 and psarc
limit<-array(c(1,1,1,-1,-1,-1),dim=c(3,2))#upper and lower limits on rho for each drug
#there is theoretical limit on the correlation coefficient rho given pasi75 and psarc
odds.pasi<-p.pasi.75/(1-p.pasi.75)
odds.psarc<-p.psarc/(1-p.psarc)

if (sa==24){#psarc of 2nd biologic if inefficacy in first biologic
odds.psarc<-odds.psarc/exp(ln.inef)}
p.psarc.new<-odds.psarc/(1+odds.psarc)
#ensure rho is always within logical limits
compare1<-array(c(sqrt(odds.pasi/odds.psarc),sqrt(odds.psarc/odds.pasi)),dim=c(3,2))

```

```

compare2<-array(c(-sqrt(odds.pasi*odds.psarc),-1/sqrt(odds.psarc*odds.pasi)),dim=c(3,2))
limit[,1]<-apply(compare1,1,min)#upper limit, always less than 1
limit[,2]<-apply(compare2,1,max)#lower limit, always greater than -1
rho.new<-ifelse(rho>limit[,1],limit[,1],ifelse(rho<limit[,2],limit[,2],rho))

#p.both=rho*SD(x)*SD(y) + Pr(x=1)P(y=1)
#This formula is the SD and not the SE of X, because we are estimating population variability not
uncertainty
p.both<-rho.new*sqrt(p.psarc.new*(1-p.psarc.new)*p.pasi.75*(1-p.pasi.75)) + p.pasi.75*p.psarc.
new #prob of both skin and psarc responses
p<-array(NA,dim=c(5,3))#probs of initial response types
colnames(p)<-c("E","I","A")
rownames(p)<-c("skin only","joints only","both","neither","AE")
p[1,]<-(1-p.adv)*(p.pasi.75-p.both) #response to skin only pasi75
p[2,]<-(1-p.adv)*(p.psarc.new-p.both) #response to joints only psarc
p[3,]<-(1-p.adv)*p.both #response to both skin and joints
p[4,]<-(1-p.adv)*(c(1,1,1)-p[3,]-p[2,]-p[1,])#no response to either
p[5,]<-p.adv #adverse event during first 12 weeks (there might not be any)

#absolute mean change in pasi from t=0 to beginning of t=1 (3months)
#,assuming a 'pasi 75.90' gives exactly a 75% reduction etc
#(in reality it will be between 75 and 90%)
PASI.no.resp<- PASI0*(0*p.pasi.0.49+ 0.5*p.pasi.50.74)/(1-p.pasi.75) #change in pasi from
baseline |no PASI 75 response
PASI.resp<- PASI0*(0.75*p.pasi.75.89+ 0.9*p.pasi.90.100)/p.pasi.75 #change in pasi from baseline
|yes PASI 75 response

PASI.resp.plac<- PASI0*(0.75*p.pasi.75.89.plac+ 0.9*p.pasi.90.100.plac)/p.pasi.75.plac #change in
pasi from baseline |yes PASI 75 response

PASI.initial<-array(NA,dim=c(3,5))#reduction in PASI from baseline given response type
rownames(PASI.initial)<-c("E","I","A")

#"E","I","A"
HAQ.initial<-array(NA,dim=c(3,5)) #Change in HAQ from baseline given response type
rownames(HAQ.initial)<-c("E","I","A")
#adjustment for placebo effect (Bravo Vergel used scenario 1)
#plac.effect <-1 = regression to mean or subject expectancy trial specific 2 = subject expectancy
generalisable to general practice
if (plac.effect ==1){#remove average placebo effect from effectiveness estimates
HAQ.initial[,1]<-HAQ1.w+HAQ.no.resp-p.psarc.plac*HAQ.resp.plac#if only skin response
HAQ.initial[,2]<-HAQ1.w+HAQ.resp-p.psarc.plac*HAQ.resp.plac#if only joints response
HAQ.initial[,3]<-HAQ1.w+HAQ.resp-p.psarc.plac*HAQ.resp.plac#if both respond
HAQ.initial[,4]<-HAQ1.w+HAQ.no.resp-p.psarc.plac*HAQ.resp.plac#if neither respond
HAQ.initial[,5]<-HAQ1.w+HAQ.no.resp-p.psarc.plac*HAQ.resp.plac#in the cycle after an
adverse event

PASI.initial[,1]<-PASI.resp-p.pasi.75.plac*PASI.resp.plac #if only skin response (await evidence
synthesis)
PASI.initial[,2]<-PASI.no.resp-p.pasi.75.plac*PASI.resp.plac #if only joints response
PASI.initial[,3]<-PASI.resp-p.pasi.75.plac*PASI.resp.plac #if both respond
PASI.initial[,4]<-PASI.no.resp-p.pasi.75.plac*PASI.resp.plac #if neither respond

```

```

PASI.initial[,5]<-PASI.no.resp-p.pasi.75.plac*PASI.resp.plac #in the cycle after an adverse event

}
if (plac.effect ==2){#no adjustment for placebo effects, assume that they will be carried forward
in general practice
HAQ.initial[,1]<-HAQ1.w+HAQ.no.resp#if only skin response
HAQ.initial[,2]<-HAQ1.w+HAQ.resp#if only joints response
HAQ.initial[,3]<-HAQ1.w+HAQ.resp#if both respond
HAQ.initial[,4]<-HAQ1.w+HAQ.no.resp#if neither respond
HAQ.initial[,5]<-HAQ1.w+HAQ.no.resp#in the cycle after an adverse event
PASI.initial[,1]<-PASI.resp #if only skin response
PASI.initial[,2]<-PASI.no.resp #if only joints response
PASI.initial[,3]<-PASI.resp #if both respond
PASI.initial[,4]<-PASI.no.resp #if neither respond
PASI.initial[,5]<-PASI.no.resp #in the cycle after an adverse event

}

# HAQ at each cycle, given type of response (while on drug)
Q<-array(0,dim=c(3,T,5))
rownames(Q)<-c(«E»,»I»,»A»)
t<-1:T
Q[,,1]<-rep(HAQ.d(t),each=3) + rep(HAQ.initial[,1],times=T)
Q[,,2]<-rep(HAQ.d(t),each=3) + rep(HAQ.initial[,2],times=T)
Q[,,3]<-rep(HAQ.d(t),each=3) + rep(HAQ.initial[,3],times=T)
Q[,,4]<-rep(HAQ.d(t),each=3) + rep(HAQ.initial[,4],times=T)
Q[,,5]<-rep(HAQ.d(t),each=3) + rep(HAQ.initial[,5],times=T)

Q<-ifelse(Q>3,Q,ifelse(Q<0,0,Q))#HAQ max is 3 and min is 0

P<-array(0,dim=c(3,T,5)) #PASI at end of cycle, given each type of response (while on drug)
rownames(P)<-c(«E”,“I”,“A”)
P[,1]<- rep(PASIO-PASI.initial[,1],times=T)
P[,2]<- rep(PASIO-PASI.initial[,2],times=T)
P[,3]<- rep(PASIO-PASI.initial[,3],times=T)
P[,4]<- rep(PASIO-PASI.initial[,4],times=T)
P[,5]<- rep(PASIO-PASI.initial[,5],times=T)

P<-ifelse(P>72,P,ifelse(P<0,0,P))#PASI max is 72 and min is 0

QALY<-EQ5D(Q,P)*0.25 #QALYs for one 3m cycle based on HAQ at start of cycle

#costs if joints are controlled
C<-array(NA,dim=c(3,T,5))#3m costs of drugs and admin
C[,1,]<-c.drug1
C[,2,]<-c.drug2
C[,3:T,]<-c.drug3

#additional costs of treating HAQ & PASI
C[,,]<-C[,,]+c.HAQ(Q)+c.pasi*P #3m costs given HAQ score
C[,,1]<-C[,,1]+c2.2 #controlled skin condition
C[,,2]<-C[,,2]+c2.1 #uncontrolled skin condition

```

```

C[,3]<-C[,3]+c2.2 #controlled skin condition
C[,4]<-C[,4]+c2.1 #uncontrolled skin condition
C[,5]<-C[,5]+c2.1 #uncontrolled skin condition

#discount rate at time t
t<-1:T
d<-rep((1+r)^(-(t-1)/4),each=3)
d<-array(d,dim=c(3,T,5))
#apply discount rates
C<-C*d
QALY<-QALY*d

#####Calculation of model outputs

#Cumulative future QALYs N(t) from time of withdrawal t=W to T
#assuming death occurs at start of period T, so last period of life confers no costs or benefits
#if no further biologics (ie palliative care)
#Independent of drug in this version of the model
QALY.n<-rep(0,times=T)#qalys after failing drug at time W
Cost.n<-rep(0,times=T)#costs after failing drug at time W

QALY.never<-rep(0,times=(40*4))#qaly if never taken drug
Cost.never<-rep(0,times=(40*4))#costs if never taken drug
#This code calculates the QALYs and costs of cohort who never started drugs

if (T<(40*4)){
for (cycle in (40*4-1):T){
QALY.never[cycle]<-(1-p.m(cycle))*(EQ5D(HAQ.never(cycle),PASIO)*disc(cycle)*0.25+QALY.
never[cycle+1])
Cost.never[cycle]<-(1-p.m(cycle))*((c.HAQ(HAQ.never(cycle))+c2.1+c.
pasi*PASIO)*disc(cycle)+Cost.never[cycle+1])
}}

for (cycle in (T-1):1){
QALY.never[cycle]<-(1-p.m(cycle))*(EQ5D(HAQ.never(cycle),PASIO)*disc(cycle)*0.25+QALY.
never[cycle+1])
Cost.never[cycle]<-(1-p.m(cycle))*((c.HAQ(HAQ.never(cycle))+c2.1+c.
pasi*PASIO)*disc(cycle)+Cost.never[cycle+1])
}

Q.t.n<-rep(0,times=T)#temporary value holder
C.t.n<-rep(0,times=T)#temporary value holder
#Costs and QALYs after final period of life, no further benefit (assume end of life)
#If model time horizon is < 40 years, assume all withdraw at T years and no further benefit of
drugs
Q.t.n[T]<-QALY.never[T]
C.t.n[T]<-Cost.never[T]
QALY.n[T]<-QALY.never[T]
Cost.n[T]<-Cost.never[T]

```

```

#This code calculates the QALYs and costs from time of withdrawal from drug at W to end of
lifetime, for every value of W
for (W in 1:(T-1)){ #W= time of withdrawal
for (cycle in (T-1):W){
Q.t.n[cycle]<-(1-p.m(cycle))*(EQ5D(HAQ.w(cycle),PASI0)*disc(cycle)*0.25+Q.t.n[cycle+1])
C.t.n[cycle]<-(1-p.m(cycle))*((c.HAQ(HAQ.w(cycle))+c.1+c.pasi*PASI0)*disc(cycle)+C.t.n[cy
cle+1])
}
QALY.n[W]<-Q.t.n[cycle]
Cost.n[W]<-C.t.n[cycle]
}
W<-1

#future net benefit given continuation current drug (1..3), time (1..T),
Q.drug<-array (NA,c(3,T))
C.drug<-array (NA,c(3,T))
rownames(C.drug)<-c("E","I","A")
rownames(Q.drug)<-c("E","I","A")

#Costs and QALYs after final period of life, no further benefit (assume end of life)
#If model time horizon is less than 40 years, assume all withdraw at T years and no further
benefit of drugs
C.drug[,T]<-Cost.never[T]
Q.drug[,T]<-QALY.never[T]

#This code calculates costs and QALYs in each period
#Remember C[choice, cycle, 2] means costs in period "cycle" while on drug "choice" if you are a
PsARC responder but not a PASI 75 responder
#and C[choice, cycle, 3] means costs in period "cycle" on drug "choice" if you are PsARC and
PASI 75 responder

#It is assumed that withdrawal rate p.long[] is exogenous ie does not depend on current health
state.
#First 12 weeks, different response probabilities p
#At the end of 12 weeks, withdrawal is ENDOGENOUS ie a decision that depends on response
#We need a rule about when to continue with a drug or not
#In base-case we continue if patient respond to PsARC
#We can try other rules as sensitivity analyses eg continue if respond to both PsARC and PASI 75
#Continue = 1 = continue if responds to PsARC (irrespective of skin), base-case
#Continue = 2 = continue if responds to both PsARC and PASI 75
#Continue = 3 = continue if responds to PASI 75 (irrespective of joints)
#Continue = 4 = continue if responds to either
#Continue = 5 = continue regardless of response

if (continue==1) {
for (cycle in (T-1):2){
for (choice in 1: 3) {
#Assume that those who continue on therapy have adequate joint control but might not have
adequate skin control (PASI 75 & PsARC)

#and assume that those who do not continue might have adequate control of PASI 75

```

```

C.drug[choice,cycle]<-(1-p.long[choice])*((p[2,choice]*C[choice,cycle,2]+p[3,choice]*C[choice,
cycle,3])/(p[2,choice]+p[3,choice])+C.drug[choice, cycle+1])
C.drug[choice,cycle]<-C.drug[choice,cycle]+p.long[choice]*((p[1,choice]*C[choice,cycle,1]+p[4,
choice]*C[choice,cycle,4])/(p[1,choice]+p[4,choice])+Cost.n[cycle+1])
C.drug[choice,cycle]<-C.drug[choice,cycle]*(1-p.m(cycle))#All cause mortality

Q.drug[choice,cycle]<-(1-p.long[choice])*((p[2,choice]*QALY[choice,cycle,2]+p[3,choice]*QAL
Y[choice,cycle,3])/(p[2,choice]+p[3,choice])+Q.drug[choice, cycle+1])
Q.drug[choice,cycle]<-Q.drug[choice,cycle]+p.long[choice]*((p[1,choice]*QALY[choice,cycle,1]
+p[4,choice]*QALY[choice,cycle,4])/(p[1,choice]+p[4,choice])+QALY.n[cycle+1])#if no efficacy
at the end of this cycle then switch
Q.drug[choice,cycle]<-Q.drug[choice,cycle]*(1-p.m(cycle))

#print(c(cycle, choice,C.drug[choice,cycle]))#debugging
}} #end choice loop, cycles loops

#If no response then get some benefit in the first cycle but none thereafter relative to palliative
care
cycle<-1
for (choice in 1: 3) {
C.drug[choice,cycle]<-(C[choice,cycle,1]+Cost.never[cycle+1])*p[1,choice]#if skin response but
no joint response then withdraw
C.drug[choice,cycle]<-C.drug[choice,cycle]+(C[choice,cycle,2]+C.drug[choice,cycle+1])*p[2,cho
ice]#if joint response but no skin response then continue
C.drug[choice,cycle]<-C.drug[choice,cycle]+(C[choice,cycle,3]+C.drug[choice,cycle+1])*p[3,cho
ice]#if response to both skin & joint then continue
C.drug[choice,cycle]<-C.drug[choice,cycle]+(C[choice,cycle,4]+Cost.
never[cycle+1])*p[4,choice]#if no response to either then withdraw
C.drug[choice,cycle]<-C.drug[choice,cycle]+(C[choice,cycle,5]+Cost.
never[cycle+1])*p[5,choice]#if adverse effect then withdraw
C.drug[choice,cycle]<-C.drug[choice,cycle]*(1-p.m(cycle)) #adjust for all cause mortality during
this cycle
Q.drug[choice,cycle]<- (QALY[choice,cycle,1]+QALY.never[cycle+1])*p[1,choice]#if
skin response but no joint response then withdraw
Q.drug[choice,cycle]<-Q.drug[choice,cycle]+(QALY[choice,cycle,2]+Q.drug[choice,cycle+1])*p[
2,choice]#if joint response but no skin response then continue
Q.drug[choice,cycle]<-Q.drug[choice,cycle]+(QALY[choice,cycle,3]+Q.drug[choice,cycle+1])*p[
3,choice]#if response to both skin & joint then continue
Q.drug[choice,cycle]<-Q.drug[choice,cycle]+(QALY[choice,cycle,4]+QALY.
never[cycle+1])*p[4,choice]#if no response to either then withdraw
Q.drug[choice,cycle]<-Q.drug[choice,cycle]+(QALY[choice,cycle,5]+QALY.
never[cycle+1])*p[5,choice]#if adverse effect then withdraw
Q.drug[choice,cycle]<-Q.drug[choice,cycle]*(1-p.m(cycle)) #adjust for all cause mortality during
this cycle
}}#end choice loop, end if
if (continue==2) {#continue only if respond to both psarc + pasi75
for (cycle in (T-1):2){
for (choice in 1: 3) {
#Assume that those who continue on therapy have adequate joint control and adequate skin
control (PASI 75 & PsARC)
C.drug[choice,cycle]<-(1-p.long[choice])*(C[choice,cycle,3]+C.drug[choice, cycle+1])

```

```
C.drug[choice,cycle]<-C.drug[choice,cycle]+p.long[choice]*((p[1,choice]*C[choice,cycle,1]+p[2,choice]*C[choice,cycle,2]+p[4,choice]*C[choice,cycle,4])/(p[1,choice]+p[2,choice]+p[4,choice]))+Cost.n[cycle+1])
```

```
C.drug[choice,cycle]<-C.drug[choice,cycle]*(1-p.m(cycle))#All cause mortality
```

```
Q.drug[choice,cycle]<-(1-p.long[choice])*(QALY[choice,cycle,3]+Q.drug[choice,cycle+1])
```

```
Q.drug[choice,cycle]<-Q.drug[choice,cycle]+p.long[choice]*((p[1,choice]*QALY[choice,cycle,1]+p[2,choice]*QALY[choice,cycle,2]+p[4,choice]*QALY[choice,cycle,4])/(p[1,choice]+p[2,choice]+p[4,choice]))+QALY.n[cycle+1])#if no efficacy at the end of this cycle then switch
```

```
Q.drug[choice,cycle]<-Q.drug[choice,cycle]*(1-p.m(cycle))
```

```
#print(c(cycle, choice,C.drug[choice,cycle]))#debugging
```

```
}} #end choice loop, cycles loops
```

```
cycle<-1
```

```
for (choice in 1: 3) {
```

```
C.drug[choice,cycle]<- (C[choice,cycle,1]+Cost.never[cycle+1])*p[1,choice]#if skin response but no joint response then withdraw
```

```
C.drug[choice,cycle]<-C.drug[choice,cycle]+(C[choice,cycle,2]+Cost.
```

```
never[cycle+1])*p[2,choice]#if joint response but no skin response then withdraw
```

```
C.drug[choice,cycle]<-C.drug[choice,cycle]+(C[choice,cycle,3]+C.drug[choice,cycle+1])*p[3,choice]#if response to both skin & joint then continue
```

```
C.drug[choice,cycle]<-C.drug[choice,cycle]+(C[choice,cycle,4]+Cost.
```

```
never[cycle+1])*p[4,choice]#if no response to either then withdraw
```

```
C.drug[choice,cycle]<-C.drug[choice,cycle]+(C[choice,cycle,5]+Cost.
```

```
never[cycle+1])*p[5,choice]#if adverse effect then withdraw
```

```
C.drug[choice,cycle]<-C.drug[choice,cycle]*(1-p.m(cycle)) #adjust for all cause mortality during this cycle
```

```
Q.drug[choice,cycle]<- (QALY[choice,cycle,1]+QALY.never[cycle+1])*p[1,choice]#if skin response but no joint response then withdraw
```

```
Q.drug[choice,cycle]<-Q.drug[choice,cycle]+(QALY[choice,cycle,2]+QALY.
```

```
never[cycle+1])*p[2,choice]#if joint response but no skin response then withdraw
```

```
Q.drug[choice,cycle]<-Q.drug[choice,cycle]+(QALY[choice,cycle,3]+Q.drug[choice,cycle+1])*p[3,choice]#if response to both skin & joint then continue
```

```
Q.drug[choice,cycle]<-Q.drug[choice,cycle]+(QALY[choice,cycle,4]+QALY.
```

```
never[cycle+1])*p[4,choice]#if no response to either then withdraw
```

```
Q.drug[choice,cycle]<-Q.drug[choice,cycle]+(QALY[choice,cycle,5]+QALY.
```

```
never[cycle+1])*p[5,choice]#if adverse effect then withdraw
```

```
Q.drug[choice,cycle]<-Q.drug[choice,cycle]*(1-p.m(cycle)) #adjust for all cause mortality during this cycle
```

```
}}#end choice loop,end if
```

```
if (continue==4) {#continue if respond to either psarc or pasi75
```

```
for (cycle in (T-1):2){
```

```
for (choice in 1: 3) {
```

```
C.drug[choice,cycle]<-(1-p.long[choice])*((p[1,choice]*C[choice,cycle,1]+p[2,choice]*C[choice,cycle,2]+p[3,choice]*C[choice,cycle,3])/(p[1,choice]+p[2,choice]+p[3,choice]))+C.drug[choice,cycle+1])
```

```
C.drug[choice,cycle]<-C.drug[choice,cycle]+p.long[choice]*(C[choice,cycle,4]+Cost.n[cycle+1])
```

```
C.drug[choice,cycle]<-C.drug[choice,cycle]*(1-p.m(cycle))#All cause mortality
```

```

Q.drug[choice,cycle]<-(1-p.long[choice])*((p[1,choice]*QALY[choice,cycle,1]+p[2,choice]*QALY[choice,cycle,2]+p[3,choice]*QALY[choice,cycle,3])/(p[1,choice]+p[2,choice]+p[3,choice]))+Q.drug[choice, cycle+1])
Q.drug[choice,cycle]<-Q.drug[choice,cycle]+p.long[choice]*(QALY[choice,cycle,4]+QALY.n[cycle+1])#if no efficacy at the end of this cycle then switch
Q.drug[choice,cycle]<-Q.drug[choice,cycle]*(1-p.m(cycle))

#print(c(cycle, choice,C.drug[choice,cycle]))#debugging
}} #end choice loop, cycles loops
cycle<-1
for (choice in 1: 3) {
C.drug[choice,cycle]<- (C[choice,cycle,1]+C.drug[choice,cycle+1])*p[1,choice]#if skin response but no joint response then withdraw
C.drug[choice,cycle]<-C.drug[choice,cycle]+(C[choice,cycle,2]+C.drug[choice,cycle+1])*p[2,choice]#if joint response but no skin response then withdraw
C.drug[choice,cycle]<-C.drug[choice,cycle]+(C[choice,cycle,3]+C.drug[choice,cycle+1])*p[3,choice]#if response to both skin & joint then continue
C.drug[choice,cycle]<-C.drug[choice,cycle]+(C[choice,cycle,4]+Cost.never[cycle+1])*p[4,choice]#if no response to either then withdraw
C.drug[choice,cycle]<-C.drug[choice,cycle]+(C[choice,cycle,5]+Cost.never[cycle+1])*p[5,choice]#if adverse effect then withdraw
C.drug[choice,cycle]<-C.drug[choice,cycle]*(1-p.m(cycle)) #adjust for all cause mortality during this cycle
Q.drug[choice,cycle]<- (QALY[choice,cycle,1]+Q.drug[choice,cycle+1])*p[1,choice]#if skin response but no joint response then withdraw
Q.drug[choice,cycle]<-Q.drug[choice,cycle]+(QALY[choice,cycle,2]+Q.drug[choice,cycle+1])*p[2,choice]#if joint response but no skin response then withdraw
Q.drug[choice,cycle]<-Q.drug[choice,cycle]+(QALY[choice,cycle,3]+Q.drug[choice,cycle+1])*p[3,choice]#if response to both skin & joint then continue
Q.drug[choice,cycle]<-Q.drug[choice,cycle]+(QALY[choice,cycle,4]+QALY.never[cycle+1])*p[4,choice]#if no response to either then withdraw
Q.drug[choice,cycle]<-Q.drug[choice,cycle]+(QALY[choice,cycle,5]+QALY.never[cycle+1])*p[5,choice]#if adverse effect then withdraw
Q.drug[choice,cycle]<-Q.drug[choice,cycle]*(1-p.m(cycle)) #adjust for all cause mortality during this cycle
}}#end choice loop,end if

#####Print outputs

#print(«QALY, cost with drugs»)
#print(Q.drug[,1])
#print(C.drug[,1])#first period outcomes and costs
#print(«QALY, cost without drug»)
#print(QALY.never[1])
#print(Cost.never[1])#no drug
#print(«Run time in seconds»)
t1<-proc.time()
time<-t1-t0#running time, seconds
#print(time[3])
out<-array(0,dim=c(4,2))
rownames(out)<-c("N","E","I","A")
colnames(out)<-c("Q","C")

```

```

out[2:4,1]<-Q.drug[,1]
out[2:4,2]<-C.drug[,1]
out[1,1]<-QALY.never[1]
out[1,2]<-Cost.never[1]
detach(tab1)
detach(tab2)
return(out)
}#end of model

sims.mn<-function(m){#mean values of simulations
m.Q<-apply(m[,1],2,mean)
m.C<-apply(m[,2],2,mean)
out<-data.frame(Q=m.Q,C=m.C)
return(out)}

sims<-function(NSims,sa1,Yr){#Run model NSims times
#deter=1 & NSims=1, deterministic; deter=2, prob sens analysis
#Yr time horizon
m<-array(NA,dim=c(NSims,4,2))
#colnames(m)<-c("QN","QE","QI","QA","CN","CE","CI","CA")
dimnames(m)<-list(NULL,c("N","E","I","A"),c("Q","C"))
for (i in 1:NSims){
m[i,]<-model(sa=sa1,deter=2, Years=Yr)#basecase
}#end loop
write.csv(m, file = paste("Results\\sa",scenario,"\\probsa.csv",sep=""))

return(m)
}#end sims

nb<-function(n){#CEACC
Lnum<-1:101
L<-(Lnum-1)*1000#willingness to pay
u<-n[,1]
c<-n[,2]
uL<-apply(u,c(1,2),function(x)x*L)
cL<-apply(c,c(1,2),function(x)x*rep(1,length(L)))
nL<-uL-cL
rownames(nL)<-L
maxnL<-apply(nL,c(1,2),max)
whichmaxnL<-apply(nL,c(1,2),which.max)
p1<-apply(whichmaxnL,1,function(x)match(x,1,0))#no treat
p2<-apply(whichmaxnL,1,function(x)match(x,2,0))#etha
p3<-apply(whichmaxnL,1,function(x)match(x,3,0))#infl
p4<-apply(whichmaxnL,1,function(x)match(x,4,0))#ada

pr<-array(NA,dim=c(length(L),4))#Pr(cost effective)
pr[,1]<-apply(p1,2,mean)
pr[,2]<-apply(p2,2,mean)
pr[,3]<-apply(p3,2,mean)
pr[,4]<-apply(p4,2,mean)
colnames(pr)<-c("N","E","I","A")
rownames(pr)<-L

```

```
write.csv(pr, file = paste("Results\\sa",scenario,"\\ceacc.csv",sep=""))
return(list(nL,pr))
}
```

Appendix 22

Sensitivity analysis comparing results from the stochastic and deterministic models

TABLE 81 Univariate sensitivity analyses using TIDI

Sa	Description	Stochastic			Deterministic			Difference (absolute value)			Difference (%)			
		Trt	QALY	Cost (£)	ICER	QALY	Cost (£)	ICER	QALY	Cost (£)	ICER	QALY	Cost (£)	ICER
<i>Average (SD)</i>														
1	Base case	N	5.171	42,168	NA	5.056908	41,817.64	NA	-0.11 (0.31)	35 (2148)	806 (4340)	-2.21 (5.74)	-0.83	4.75 (9.95)
		A	6.58	68,638	Ex dom	6.370075	68,465.66	Ex dom	-0.21	-172		-3.19	-0.25	
		E	7.001	74,841	17,853	6.775944	74,519.33	19,023.27	-0.23	-322	1170	-3.21	-0.43	6.56
		I	7.308	88,442	44,326	7.067269	88,103.69	46,629.52	-0.24	-338	2304	-3.29	-0.38	5.20
2	Rebound in HAQ is small after withdrawal (base case = initial gain)	N	5.171	42,168	NA	5.056908	41,817.64	NA	-0.11	-350		-2.21	-0.83	
		A	7.225	67,710	Ex dom	7.314953	67,159.74	Ex dom	0.09	-550		1.25	-0.81	
		E	7.792	73,706	12,035	7.923641	72,933.09	10,853.98	0.13	-773	-1181	1.69	-1.05	-9.81
		I	8.188	87,174	34,006	8.346960	86,335.03	31,659.22	0.16	-839	-2347	1.94	-0.96	-6.90
3	Rapid worsening in HAQ with no treatment (upper 95% of CI)	N	3.309	44,434	NA	3.225453	44,348.90	NA	-0.08	-85		-2.52	-0.19	
		A	4.967	70,829	Ex dom	4.842184	70,577.36	Ex dom	-0.12	-262		-2.51	-0.36	
		E	5.447	76,985	15,221	5.313432	76,540.66	15,417.67	-0.13	-444	197	-2.45	-0.58	1.29
		I	5.786	90,609	40,248	5.647306	90,066.22	40,510.98	-0.14	-543	263	-2.40	-0.60	0.65
4	Log-PASI utility function (Abbott ¹⁵⁷) (base case linear)	N	4.558	42,168	NA	5.843696	41,817.64	NA	1.29	-350		28.21	-0.83	
		A	6.001	68,638	Ex dom	7.005181	68,465.66	Ex dom	1.00	-172		16.73	-0.25	
		E	6.39	74,841	17,835	7.316303	74,519.33	22,206.66	0.93	-322	4372	14.50	-0.43	24.51
		I	6.769	88,442	35,898	7.643365	88,103.69	41,534.5	0.87	-338	5637	12.92	-0.38	15.70
5	No correlation between PASI 75 and PsAPC (base case = 0.4)	N	5.171	42,168	NA	5.056908	41,817.64	NA	-0.11	-350		-2.21	-0.83	
		A	6.571	68,968	Ex dom	6.361208	68,808.52	Ex dom	-0.21	-159		-3.19	-0.23	
		E	6.997	74,990	17,979	6.771297	74,673.95	19,165.02	-0.23	-316	1186	-3.23	-0.42	6.60
		I	7.303	88,641	44,558	7.062126	88,314.90	46,903.65	-0.24	-326	2346	-3.30	-0.37	5.26
6	RCT results fully generalisable to clinical practice (no adjustment for placebo effect)	N	5.171	42,168	NA	5.056908	41,817.64	NA	-0.11	-350		-2.21	-0.83	
		A	6.637	68,561	Ex dom	6.429905	68,387.96	Ex dom	-0.21	-173		-3.12	-0.25	
		E	7.068	74,752	17,178	6.847586	74,426.29	18,210.23	-0.22	-326	1032	-3.12	-0.44	6.01
		I	7.381	88,344	43,371	7.146598	88,000.67	45,397.44	-0.23	-343	2026	-3.18	-0.39	4.67

Sa	Description	Trt	Stochastic			Deterministic			Difference (absolute value)			Difference (%)		
			QALY	Cost (£)	ICER	QALY	Cost (£)	ICER	QALY	Cost (£)	ICER	QALY	Cost (£)	ICER
9	Exponential HAQ cost function (Abbott ¹⁵¹) (base case linear)	N A E	5.171 6.580 7.001	63,052 82,129 86,502	NA Ex dom 12,813	5.056908 6.370075 6.775944	63,146.27 81,718.09 85,961.47	NA Ex dom 13,272.09	-0.11 -0.21 -0.23	94 -411 -541	459	-2.21 -3.19 -3.21	0.15 -0.50 -0.62	3.58
		I	7.308	99,045	40,878	7.067269	98,402.16	42,703.76	-0.24	-643	1826	-3.29	-0.65	4.47
12	Inpatient treatment for uncontrolled psoriasis	N A I	5.171 6.580 7.308	151,496 165,282 175,157	NA 9787 13,557	5.056908 6.370075 7.067269	15,1186.30 165,046.80 174,843.20	10,555.06 14,051.12	-0.11 -0.21 -0.24	-310 -235 -314	768	-2.21 -3.19 -3.29	-0.20 -0.14 -0.18	7.85 3.64
		E	7.001	178,530	Dom	6.775944	178,192.40	Dom	-0.23	-338	494	-3.21	-0.19	
13	Cost per 3 months per 1-unit change in HAQ is £183 (US data) ¹⁵² (base case £103)	N A E	5.171 6.580 7.001	52,548 77,518 83,224	NA Ex dom 16,761	5.056908 6.370075 6.775944	52,668.62 77,868.59 83,422.65	Ex dom Ex dom 17,890.27	-0.11 -0.21 -0.23	121 351 199	1129	-2.21 -3.19 -3.21	0.23 0.45 0.24	5.23 6.74
		I	7.308	96,562	43,468	7.067269	96,747.99	45,740.41	-0.24	186	2272	-3.29	0.19	5.23
14	Change in utility per 1-unit change in HAQ is -0.45 (Wyeth ¹⁵³) (base case -0.29)	N A E	0.846 2.905 3.589	42,168 68,638 74,841	NA Ex dom 11,913	0.649240 2.564543 3.225364	41,817.64 68,465.66 74,519.33	Ex dom Ex dom 12,694.14	-0.20 -0.34 -0.36	-350 -172 -322	781	-23.26 -11.72 -10.13	-0.83 -0.25 -0.43	6.56
		I	3.954	88,442	37,280	3.567963	88,103.69	39,650.89	-0.39	-338	2371	-9.76	-0.38	6.36
15	HAQ improves while on drug (lower 95% of CI) (base case no change)	N A E	5.171 7.845 8.492	42,168 66,823 72,704	NA Ex dom 9194	5.056908 7.903268 8.564890	41,817.64 66,346.63 72,046.82	Ex dom Ex dom 8617.258	-0.11 0.06 0.07	-350 -476 -657	577	-2.21 0.74 0.86	-0.83 -0.71 -0.90	-6.27
		I	8.959	86,065	28,635	9.046183	85,368.63	27,679.20	0.09	-696	-956	0.97	-0.81	-3.34
16	High rate of withdrawal (upper 95% of CI)	N A E	5.171 6.302 6.635	42,168 62,085 66,604	NA Ex dom 16,690	5.056908 6.046479 6.349696	41,817.64 61,904.14 66,326.52	Ex dom Ex dom 18,958.16	-0.11 -0.26 -0.29	-350 -181 -277	2268	-2.21 -4.05 -4.30	-0.83 -0.29 -0.42	13.59
		I	6.876	77,323	44,451	6.567394	77,024.66	49,141.99	-0.31	-298	4691	-4.49	-0.39	10.55

continued

Sa	Description	Trt	Stochastic			Deterministic			Difference (absolute value)			Difference (%)		
			QALY	Cost (£)	ICER	QALY	Cost (£)	ICER	QALY	Cost (£)	ICER	QALY	Cost (£)	ICER
26	Rebound to NH after withdrawal (base case): rebound to initial gain)	N A E I	5.171 5.846 6.104 6.307	42,168 69,701 76,145 89,900	NA Ex dom 36,408 67,759	5.056908 5.756078 6.030152 6.235706	41,817.64 69,314.27 75,550.09 89,252.99	NA Ex dom 34,659.80 66,663.29	-0.11 -0.09 -0.07 -0.07	-350 -387 -595 -647	-2.21 -1.54 -1.21 -1.13	-0.83 -0.55 -0.78 -0.72		
31	No costs of psoriasis (base case: UK data ^{187,192})	N A E	5.171 6.580 7.001	28,908 56,792 62,209	NA Ex dom 18,196	5.056908 6.370075 6.775944	28,577.05 56,648.07 61,912.54	NA Ex dom 19,391.97	-0.11 -0.21 -0.23	-331 -144 -296	-2.21 -3.19 -3.21	-1.14 -0.25 -0.48		
32	Schering-Plough estimates of cost per PASI point excluding phototherapy ¹⁵²	N A E I	5.171 6.580 7.001 7.308	55,479 80,496 87,252 99,438	NA Ex dom 17,361 39,715	5.056908 6.370075 6.775944 7.067269	55,158.54 80,366.29 86,959.47 99,146.39	NA Ex dom 18,499.28 41,832.70	-0.11 -0.21 -0.23 -0.24	-320 -130 -293 -292	-2.21 -3.19 -3.21 -3.29	-0.58 -0.16 -0.34 -0.29		
33	Schering-Plough estimates of cost per PASI point including phototherapy ¹⁵²	N A E I	5.171 6.580 7.001 7.308	112,633 131,482 141,118 146,187	NA 13,381 Ex dom 20,188	5.056908 6.370075 6.775944 7.067269	112,333.80 131,382.80 140,834 145,961.90	NA 14,506.15 Ex dom 20,911.05	-0.11 -0.21 -0.23 -0.24	-299 -99 -284 -225	-2.21 -3.19 -3.21 -3.29	-0.27 -0.08 -0.20 -0.15		
34	The effectiveness of biologic therapy lasts no longer than 10 years, compared with palliative care	N A E I	5.171 5.875 6.130 6.325	42,168 66,044 71,556 83,779	NA Ex dom 30,645 62,746	5.056908 6.730591 7.252346 7.626992	41,817.64 76,090.30 84,039.00 100,971.10	NA Ex dom 19,231.40 45,194.96	-0.11 0.86 1.12 1.30	-350 10,046 12,483 17,192	-2.21 14.56 18.31 20.58	-0.83 15.21 17.45 20.52		

A, adalimumab; E, etanercept; I, infliximab; Ex dom; extended dominated; N, no treatment/palliative care; NA, not available; Sa, sensitivity analysis number; Trt, treatment.

TABLE 82 Subgroup analyses

Sa	Description	Stochastic				Deterministic				Difference (absolute value)				Difference (%)			
		Trt	QALY	Cost (£)	ICER	QALY	Cost (£)	ICER	QALY	Cost (£)	ICER	QALY	Cost (£)	ICER	QALY	Cost (£)	ICER
<i>Average (SD)</i>																	
10	Baseline HAQ 1.8 (BSR register ⁽⁸⁾) (base case 1.05)	N	2.090	46,594	NA	1.943630	46,120.50	NA	NA	1.943630	46,120.50	NA	NA	1.943630	46,120.50	NA	NA
		A	3.397	73,207	Ex dom	3.078577	73,014.84	Ex dom	Ex dom	3.078577	73,014.84	Ex dom	Ex dom	3.078577	73,014.84	Ex dom	Ex dom
		E	3.804	79,431	19,156	3.446191	79,121.38	21,963.09	21,963.09	3.446191	79,121.38	21,963.09	21,963.09	3.446191	79,121.38	21,963.09	21,963.09
		I	4.101	93,046	45,898	3.712620	92,740.15	51,115.92	51,115.92	3.712620	92,740.15	51,115.92	51,115.92	3.712620	92,740.15	51,115.92	51,115.92
11	Baseline PASI 12.5 (base case 7.5)	N	4.810	66,811	NA	4.695834	66,426.42	NA	NA	4.695834	66,426.42	NA	NA	4.695834	66,426.42	NA	NA
		A	6.257	90,422	16,310	6.047895	90,197.16	17,581.12	17,581.12	6.047895	90,197.16	17,581.12	17,581.12	6.047895	90,197.16	17,581.12	17,581.12
		E	6.661	98,214	19,319	6.435715	97,846.56	19,724.06	19,724.06	6.435715	97,846.56	19,724.06	19,724.06	6.435715	97,846.56	19,724.06	19,724.06
		I	7.012	107,988	27,778	6.771620	107,620.70	29,098.09	29,098.09	6.771620	107,620.70	29,098.09	29,098.09	6.771620	107,620.70	29,098.09	29,098.09
7	Baseline PASI 12.5, and continue after 3 months only if respond to both PsARC and PASI 75	N	4.810	66,811	NA	4.695834	66,426.42	NA	NA	4.695834	66,426.42	NA	NA	4.695834	66,426.42	NA	NA
		E	5.315	74,865	Ex dom	5.178952	74,614.15	Ex dom	Ex dom	5.178952	74,614.15	Ex dom	Ex dom	5.178952	74,614.15	Ex dom	Ex dom
		A	5.790	81,637	15,125	5.618303	81,512.32	16,353.82	16,353.82	5.618303	81,512.32	16,353.82	16,353.82	5.618303	81,512.32	16,353.82	16,353.82
		I	6.717	101,796	21,739	6.510411	101,692.60	22,620.91	22,620.91	6.510411	101,692.60	22,620.91	22,620.91	6.510411	101,692.60	22,620.91	22,620.91
8	Baseline PASI 12.5, and continue after 3 months if respond to either PsARC or PASI 75	N	4.810	66,811	NA	4.695834	66,426.42	NA	NA	4.695834	66,426.42	NA	NA	4.695834	66,426.42	NA	NA
		A	6.448	93,601	16,349	6.211228	93,310.24	17,740.49	17,740.49	6.211228	93,310.24	17,740.49	17,740.49	6.211228	93,310.24	17,740.49	17,740.49
		E	6.665	98,293	21,609	6.435715	97,846.56	20,207.45	20,207.45	6.435715	97,846.56	20,207.45	20,207.45	6.435715	97,846.56	20,207.45	20,207.45
		I	7.187	111,940	26,177	6.930332	111,524.30	27,653.19	27,653.19	6.930332	111,524.30	27,653.19	27,653.19	6.930332	111,524.30	27,653.19	27,653.19
21	Baseline PASI 12.5, and annual inpatient treatment for uncontrolled psoriasis (base case UVB)	N	4.810	171,746	NA	4.695834	171,214.40	NA	NA	4.695834	171,214.40	NA	NA	4.695834	171,214.40	NA	NA
		A	6.257	183,184	7901	6.047895	182,733.20	8519.481	8519.481	6.047895	182,733.20	8519.481	8519.481	6.047895	182,733.20	8519.481	8519.481
		I	7.012	191,216	10,636	6.77162	190,727.30	11,045.79	11,045.79	6.77162	190,727.30	11,045.79	11,045.79	6.77162	190,727.30	11,045.79	11,045.79
		E	6.661	197,741	Dom	6.435715	197,177.50	Dom	Dom	6.435715	197,177.50	Dom	Dom	6.435715	197,177.50	Dom	Dom
30	Baseline PASI zero (base case 7.5)	N	5.713	28,908	NA	5.598518	28,577.05	NA	NA	5.598518	28,577.05	NA	NA	5.598518	28,577.05	NA	NA
		A	7.064	56,792	Ex dom	6.853345	56,648.07	Ex dom	Ex dom	6.853345	56,648.07	Ex dom	Ex dom	6.853345	56,648.07	Ex dom	Ex dom
		E	7.512	62,209	18,512	7.286287	61,912.54	19,751.22	19,751.22	7.286287	61,912.54	19,751.22	19,751.22	7.286287	61,912.54	19,751.22	19,751.22
		I	7.752	77,704	64,744	7.510744	77,381.28	68,916.40	68,916.40	7.510744	77,381.28	68,916.40	68,916.40	7.510744	77,381.28	68,916.40	68,916.40

A, adalimumab; E, etanercept; I, infliximab; Ex dom; extended dominated; N, no treatment/palliative care; NA, not available; Sa, sensitivity analysis number; Trt, treatment.

TABLE 83a Sequential analyses: stochastic – costs and QALYs of biologics used as second-line therapy for patients with mild-to-moderate skin disease if first biologic fails

Sa	Description	Trt	Stochastic					Difference (absolute value)											
			QALY	Cost	ICER assuming I was used first line	ICER assuming E was used first line	ICER assuming A was used first line	QALY	Cost	ICER assuming I was used first line	ICER assuming E was used first line	ICER assuming A was used first line							
24	Second-line biologic if first failed for inefficacy	N	5.171	42,168															
		A	5.827	54,394	18,652	NA	NA												
		E	6.142	58,783	17,114	NA	17,114												
25	Second-line biologic if first failed for AEs	I	6.410	68,630	24,406	36,746													
		N	5.171	42,168			NA												
		A	6.273	61,430	17,486	NA	NA												
		E	6.597	65,780	16,554	NA	16,554												
		I	6.831	76,205	26,445	44,569	44,569												

A, adalimumab; E, etanercept; I, infliximab; Ex dom; extended dominated; N, no treatment/palliative care; NA, not available; Sa, sensitivity analysis number; Trt, treatment.

TABLE 83b Sequential analyses: deterministic – costs and QALYs of biologics used as second-line therapy for patients with mild-to-moderate skin disease if first biologic fails

Sa	Description	Trt	Deterministic					Difference (%)											
			QALY	Cost	ICER assuming I was used first line	ICER assuming E was used first line	ICER assuming A was used first line	QALY	Cost	ICER assuming I was used first line	ICER assuming E was used first line	ICER assuming A was used first line							
24	Second-line biologic if first failed for inefficacy	N	5.056908	41,817.64															
		A	5.613686	53,909.16	Ex dom	21,716.93	NA												
		E	5.886774	58,119.91	19,644.46	NA	19,644.46												
25	Second-line biologic if first failed for AEs	I	6.123890	67,934.90	NA	27,490.47	41,393.19												
		N	5.056908	41,817.64			NA												
		A	6.013680	61,253.68	Ex dom	20,314.18	NA												
		E	6.306562	65,514.32	18,962.59	NA	18,962.59												
		I	6.516858	75,926.05	NA	29,159.41	49,509.98												

A, adalimumab; E, etanercept; I, infliximab; Ex dom; extended dominated; N, no treatment/palliative care; NA, not available; Sa, sensitivity analysis number; Trt, treatment.

Feedback

The HTA programme and the authors would like to know your views about this report.

The Correspondence Page on the HTA website (www.hta.ac.uk) is a convenient way to publish your comments. If you prefer, you can send your comments to the address below, telling us whether you would like us to transfer them to the website.

We look forward to hearing from you.